



Downtown Austin

wayfinding graphics manual

June 24, 2014

★ Prepared for: City of Austin, Texas

"It is the policy of the City of Austin to involve certified Minority Owned Business Enterprises (MBEs) and Woman Owned Business Enterprises (WBEs) in City contracting. MBE and WBE goals for this solicitation are contained in Volume 3, M/WBE Procurement Program Package."

"It is the policy of the City of Austin to involve certified Minority Owned Business Enterprises (MBEs) and Woman Owned Business Enterprises (WBEs) in City contracting. MBE and WBE goals for this solicitation are contained in Volume 3, M/WBE Procurement Program Package."

table of contents

Section 1 ADMINISTRATION

- 1.1 Introduction
- 1.3 Administration & Management Responsibilities
- 1.4 Maintenance Procedures
- 1.8 Criteria for Inclusion
- 1.12 Re-Ordering Information

Section 2 GRAPHIC SIGN STANDARDS

- 2.0 Design Standards
- 2.18 Signage Drawings
- 2.141 Construction Details

Section 3 TECHNICAL SPECIFICATIONS



note

PHASES 1-4 BID

The following list of pages have been omitted from this document (on purpose), because the sign types are NOT included within Phases 1-4:

2.10 – 2.11

2.16 – 2.17

2.20 – 2.21

2.25

2.28 – 2.29

2.31 – 2.40

2.53 – 2.58

2.65 – 2.68

2.83 – 2.90

2.103 – 2.104

2.115 – 2.138

2.153 – 2.158

2.166 – 2.167

3.1 – 3.11



section 1

ADMINISTRATION

- 1.1 Introduction
- 1.3 Administration & Management Responsibilities
- 1.4 Maintenance Procedures
- 1.8 Financing Strategies
- 1.9 Criteria for Inclusion
- 1.13 Re-Ordering Information

INTRODUCTION

As Austin continues to grow, it has transitioned from a medium-sized town to a large urban metropolitan area. At its core is Downtown, with a unique blend of tourism attractions, government facilities, retail, dining, outdoor activities and, of course, music.

Downtown Austin draws seven million visitors annually. In 2010, tourism generated \$3.9 billion in visitor spending and is vital to the health of Downtown and the City. Visiting Austin is not solely about the individual destinations you may visit, but about the overall experience you have and the people you meet.

As the City continues to build its infrastructure and enhance the quality of life for its growing resident and business population, it has identified the implementation of a Downtown Wayfinding System as an initiative that will enhance the experience for everyone. The development of an overall wayfinding philosophy and graphic standard can provide valuable information and communicate an organized and friendly city, without detracting from its visual beauty. In contrast, ignoring or having an unregulated, haphazard approach to this issue will only create sign clutter, less efficient navigation and an unwelcoming perception of the Downtown.

In December of 2011, the City hired MERJE, with a team of local Austin firms, including McCann Adams Studio, Estillo Communications, I.T. Gonzalez Engineers and Gannett Fleming to develop the Downtown Austin Wayfinding System.

The result of that collaboration was the Downtown Austin Wayfinding Master Plan. It created an overall wayfinding philosophy for Downtown, identified a variety of possible wayfinding tools, analyzed existing conditions in Downtown and developed a set of graphic standards that can be implemented, enforced and maintained overtime.

The Wayfinding Master Plan also outlined priority projects, initiatives and approaches to help establish a Phasing Plan for both short term and long term opportunities. Phasing is based on the complexity of the system and the funding available.

This project has been holistic in its approach and considered all forms of wayfinding tools, including the integration of technology elements, environmental cues, support materials, signage, landscaping, lighting and public art, presented through a single voice and graphic language that defines Downtown.

This Wayfinding Graphics Manual has organized all of the signage components outlined in the Wayfinding Master Plan, from typefaces and paint colors, to sign drawings and construction details. Sign Location plans showing the location of each sign in Downtown and a Message Schedule showing the text on each sign is also included. This manual provides everything needed to for a professional fabricator to build and implement the various elements of The Downtown Austin Wayfinding Master Plan.

Thank you to all the individuals who took the time and energy to share their ideas and perceptions to create this Manual. We deeply appreciate your participation, knowledge and enthusiasm.



This page is intentionally left blank.

MANAGEMENT

The maintenance of the sign system is essential to its success. Worn, outdated or damaged signs do not present a positive image and do not build trust among the end-user, a critical component to wayfinding.

ANNUAL BUDGETS

Generally 10% - 15% of the total phasing cost should be established for annual maintenance of the system.

Initial "attic stock" of parts should be included in the base bid of each phase of the project.

By purchasing materials and parts in a large quantity the City will reduce its overall costs. Attic stock can include poles (painted), sign panels (painted/no lettering), brackets finished and painted, and other parts.

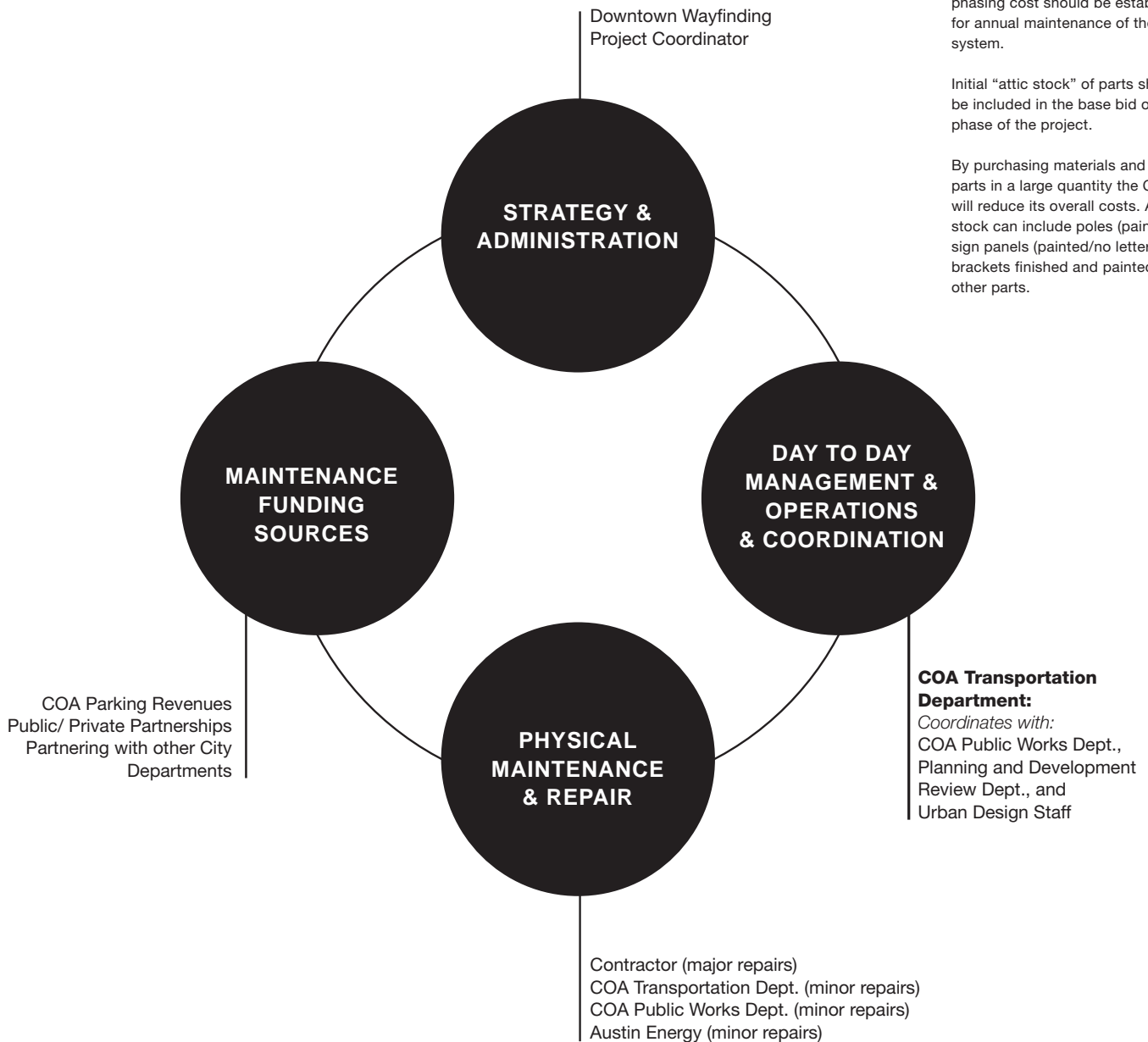

SHORT & LONG TERM MAINTENANCE EXPECTATIONS

To ensure that the Downtown Austin Wayfinding System has a long life and continues to look like the high quality system it is, the following is a list of guidelines for repair and replacement and must be followed closely.

Sign Longevity	0-4 Years	5-9 years	10-15+ years
Design and Planning	<p>Design: General Evaluation of positive and negative aspects of the system.</p> <p>Planning: City of Austin In-house maintenance based on new request and circulation/destination updates.</p>	<p>Design: General Evaluation of positive and negative aspects of the system.</p> <p>Planning: Contract with a consultant to analyze major changes to the City of Austin and necessary system adjustments. 1 or 2 updates possible during this time period.</p>	<p>If the system has not been analyzed since implementation, a major updating is likely to be needed. Outside consultants will be required to review and inventory the system, as well as make suggested changes based on new circulation, destinations, etc.</p>
Vandalism	<p>Annual cleaning/repair. Stickers and graffiti are most common.</p> <p>Cleaning solvents and Goo-Gone are typical products utilized.</p>	<p>Parts replacements and full sign replacement as needed.</p> <p>Cleaning solvents and Goo-Gone are typical products utilized.</p>	<p>Parts replacements / full sign replacement as needed.</p> <p>Cleaning solvents and Goo-Gone are typical products utilized.</p>
Cleaning Schedule	Annual Cleaning	Annual Cleaning	Annual Cleaning
Management / Administration	<p>Weekly coordination during initial installation, transitioning to quarterly between City of Austin and fabricator during year 1 and 2. On-going day-to-day monitoring of the system, based on COA Staff observations, safety issues and citizens' reports.</p>	<p>Annual coordination between City of Austin and fabricator. Day-to-day monitoring of the system, based on Facilities observations, safety issues and citizens' reports.</p>	<p>Annual coordination between City of Austin and fabricator. Day-to-day monitoring of the system, based on Facilities observations, safety issues and citizens' reports.</p>
Breakaway Product: Transpo	<p>Maintenance Free - Covered under Warranty for 3 years.</p>	<p>Maintenance Free - consider general review as part of yearly inspection process.</p>	<p>Maintenance Free - consider general review as part of yearly inspection process.</p>
Reflectivity Life Span: 3M High Intensity Diamond Grade	<p>Covered under warranty for 5-7 years.</p>	<p>Covered under warranty for 5-7 years.</p> <p>Reflectivity may be effective beyond the warranty period. Individual signs may require sheeting to be replaced during this time period.</p>	<p>Reflectivity becomes less effective, if not previously replaced. 10 – 15 years is the maximum lifespan.</p>

Sign Longevity	0-4 Years	5-9 years	10-15+ years
Custom Color Life Span: 3M High Intensity Diamond Grade	<p>Covered under warranty for 3 years.</p> <p>Color generally maintained beyond warranty period, depends on direction sign panel is facing.</p>	<p>Fading may begin depending on the direction sign panel is facing. Individual signs may require sheeting to be replaced during this time period</p>	<p>Fading occurs, if not previously replaced. 10 -15 years is the maximum lifespan.</p>
General Materials: Aluminum Sign Panels & Posts	<p>Specifications require 5 year fabricator warranty for workmanship.</p> <p>General wear-and-tear maintenance required.</p>	<p>General wear-and-tear maintenance required.</p>	<p>General wear-and-tear maintenance required.</p>
Painted Surfaces	<p>Covered under manufacturers warranty.</p> <p>General maintenance and touch-up will be required.</p>	<p>Warranty expires. Typically color holds up beyond warranty period. Fading may begin depending on the direction sign panel is facing. Individual signs may require individual parts to be replaced during this time period.</p>	<p>Fading occurs – based on direction sign panel is facing. 10 – 15 years is the maximum lifespan to expect.</p>
Sign Panels / Fasteners	<p>Specifications require 5 year fabricator warranty for workmanship. General repairs and replacement due to auto incidents or vandalism. Inspect welds and fasteners for connection integrity.</p>	<p>Quantity of repairs increases, if not maintained previously. Inspect welds and fasteners for connection integrity.</p>	<p>Consider full inventory of system and repairs based on consistency of maintenance and up-keep over the years.</p>
Brackets/ Fins / Details	<p>Specifications require 5 year fabricator warranty. General repairs and replacement of parts due to auto incidents or vandalism. Inspect welds and fasteners for connection integrity.</p>	<p>Quantity of repairs increases, if not maintained previously. Inspect welds and fasteners for connection integrity.</p>	<p>Consider full inventory of system and repairs based on consistency of maintenance and up-keep over the years.</p>
Concrete Footers	<p>Maintenance free. Inspect structural integrity – similar to any construction project.</p>	<p>Maintenance free. Inspect structural integrity – similar to any construction project.</p>	<p>Maintenance free. Inspect structural integrity – similar to any construction project.</p>

CLEANING

The Downtown Austin Wayfinding System must be periodically cleaned to maintain their clarity and effectiveness.

MAINTENANCE AND REPLACEMENT

To ensure that the Downtown Austin Wayfinding System continues to function properly, the following is a list of guidelines for repair and replacement and must be followed closely.

OVERVIEW:

As the Downtown Austin Wayfinding system transitions from a project to a program, three main areas emerge that will require continued oversight; Maintenance, Operations, and Expansion. The maintenance of the sign system is essential to its success. Screws and bolts must be tightened periodically. Worn, outdated or damaged signs do not present a positive image and do not build trust among the end-user, a critical component to wayfinding. Procedures should be put into place to track when materials are ready for regular maintenance as well ways to address damaged or outdated signage.

While the boundary used to begin development of the system hugged Austin's downtown, the components of the system have the capability to be expanded beyond Downtown into adjacent emerging and established neighborhoods. This requires the establishment of a single point of contact who can field expansion requests, evaluate their appropriateness, and work to implement that new portion of the system. This will allow the system to smoothly transition from the "Downtown Austin Wayfinding System" to the "Austin Wayfinding System".

MAINTENANCE & OPERATIONS STRATEGY:

The Sign Shop Division for the City of Austin is housed within the Austin Transportation Department. The Sign Shop Division is equipped to make aluminum panel street signs such as street names, traffic signs, and directional signage to major destinations. Currently, requests for service or a new sign are routed through the Austin 3-1-1 service center. Once logged as a customer service request, the Sign Shop Division reviews the request, and if valid, assigns it to a work crew. This procedure utilizes GIS data sets and MAXIMO to track active requests and those that have been closed out. The

components included in the Downtown Wayfinding System, however, will require special consideration for service, replacement, and expansion. Additionally, several of the pieces of the Downtown Wayfinding System are prefabricated and will require reordering or adequate "attic stock" to be provided for timely maintenance and replacement. One point of contact should be assigned as the conduit for processing these orders once they've been entered as a request.

(See flow chart on page 1.3)

COORDINATION WITH ADJACENT AND OVERLAPPING WAYFINDING SYSTEMS:

The current boundaries of the Downtown Wayfinding System touch on existing and proposed wayfinding systems. These include government campuses for Travis County, districts such as 2nd street, and education campuses such as the University of Texas. As the Downtown Wayfinding System expands, coordination with the programs will need to occur. Below is a list of systems either already in place, proposed, or could potentially have their own system.

- Breckenridge Medical Center
- Waller Creek
- 2nd Street District
- Seaholm District
- Central Campus (Travis County)
- University of Texas
- Capitol Complex
- Capital Metro Wayfinding System
- The Trail Foundation
- Parks and Recreation Department
- City of Austin Bicycle Program

Type	Components	Description	Further Outreach
District Signage	District Gateway (DIST.1), District Gateway Small (DIST.1A), District Gateway Med. (DIST.1B), District ID Banner (DIST.2), District Subheader (DIST.3)	District Signage can help to define particular Downtown areas and districts while supporting the overall pedestrian and vehicular wayfinding system. In addition it can help communicate a welcoming and celebratory message to visitors and offer opportunities for public/private partnerships.	ATD Banner Program, Downtown Austin Alliance, PDR – Urban Design, Economic Development Department, Austin business owners, Austin neighborhood associations, Austin neighborhood contact teams.
Destination Signage	Destination ID Small (DEST.1), Destination ID Large (DEST.2)	Destination signage provides final notification of arrival at the end of a journey. In addition, with strategic placement, it can help identify the correct way to access a destination upon arrival.	Downtown Destinations, Destinations outside the Downtown
Interpretive Signage	PINTERP.1	These can be either static or electronic that tell the story of a place through images, graphics, text, and sometimes audio. The signs may be placed as an organized tour, adjacent to key sites or dispersed along a path.	East Austin Tejano Trail, Mexican/American Heritage Corridor (5th Street), City of Austin Preservation Office
Interpretive Signage (Trail)	TINTERP.1	These can be either static or electronic that tell the story of a place through images, graphics, text, and sometimes audio. The signs may be placed as an organized tour, adjacent to key sites or dispersed along a trail.	Parks and Recreation Department, Waller Creek Conservancy, Shoal Creek Conservancy, Peise Park Conservancy, Trail Foundation
TRAIL SIGNAGE			
Pedestrian Trail Marker	Pedestrian Trail Marker (TID.1), Pedestrian Trail Marker (TID.2)	Austin's trail system is greatly loved and greatly used. Currently, the system is equipped with little to no wayfinding elements which makes it difficult to identify entries to the trail, where the trails connect, or where major destinations along the trail are located. Using the palette of signs provided in this manual, there is an opportunity to enhance and highlight one of Austin's greatest public amenities.	Parks and Recreation Department, Waller Creek Conservancy, Shoal Creek Conservancy, Peise Park Conservancy, Trail Foundation
Trail Destination Marker	Trail Destination Marker (TDEST.1&2)		
Pedestrian Map/Directional	Pedestrian Map / Directional (TMAP.1)		
Pedestrian Marker	Pedestrian Marker (TMAP.2)		
Trail Pedestrian Kiosk (Static)	Pedestrian Kiosk Static Info (TKIOSK.5/6)		
Trail Pedestrian Kiosk (Digital)	Pedestrian Kiosk Digital Info (TKIOSK.5/6)		

EXPANDING THE SYSTEM

Several of the proposed components within the Downtown Wayfinding System have the potential to become on-going projects and programs. Below is a table outlining components with potential for further development.

CRITERIA RANKING SYSTEM

The Downtown Austin Wayfinding System looks to include a variety of destinations. The following Criteria Ranking System provides guidelines in determining which type of destinations qualify and what types of wayfinding tools they may be listed on.

TWO-STEP INCLUSION PROCESS:

Listed here is a two-step process for determining whether or not a particular destination is eligible for inclusion in the Downtown Austin Wayfinding System Program.

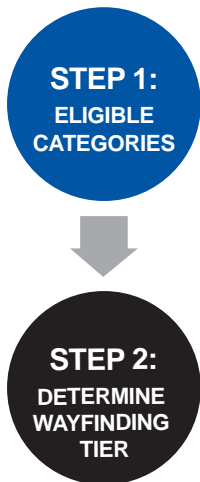

● **STEP 1: ELIGIBLE CATEGORIES**
Destinations must fall under one of the following categories and meet the criteria established.

100. COMMERCIAL ATTRACTIONS

101. Arboreta and Botanical Gardens: A place where a wide variety of live plants are cultivated for scientific, education, and ornamental purposes, often including a library, an herbarium, greenhouses, laboratory spaces, and open grounds. These are facilities with a reasonable guarantee of permanence, and where adequate labeling of plants is common and proper documentation of the collection takes place. Must have facilities that are open to the general public.

102. Breweries: A licensed site which shall be open to the general public for tours, tasting and sales, a minimum of 800 hours per year, and provide an educational format for informing visitors about beer and beer processing.

103. Caverns and Other Unique Natural Areas: A naturally occurring area or site of interest to the general public. Such areas may include caverns, waterfalls, caves, or special rock formations.

104. Specialty Shopping Centers: A group of 12 or more specialty shops (antique, craft, outlet, farmers' market, etc.) retail stores, and restaurants with ample parking facilities. Specialty shops must offer goods or services of interest to tourists and that derive the major portion of their income during the normal business season from motorists that do not reside in the immediate area. The goods or services shall be readily available to tourists, without the need for scheduling appointments or return trips.

105. Wineries: A licensed site, which produces a maximum of 200,000 gallons of wine per year. Winery shall maintain a minimum of 3000 vines or five acres of vineyard on site. Winery must be open to the general public for tours, tasting and sales a minimum of 1500 hours per year,

and provide an educational format for informing visitors about wine and wine processing.

106. Zoos, Zoological Gardens, Animal Parks and Aquariums: A place where animals, reptiles or fish are kept, often indoor and outdoor spaces. The facility must have spaces that are open to the general public.

200. COMMUNITY DESTINATIONS

201. Business Districts: An area within a city or borough which is officially designated as a business district by government officials.

202. Courthouses/Government Buildings: A public building, structure, or complex used by a federal, county, state or municipal government for the purposes of convening official legal activities and that is open to the public.

203. Fairgrounds: Includes county and state fairgrounds.

204. Military Bases: A facility operated by the State or Federal government for training or support of military troops, or for maintaining and storing military equipment.

205. Shopping Centers – Neighborhood: A group of 15 or more shops, retail stores, or restaurants usually concentrated within a neighborhood, often at a corner, that functions as the node or nucleus of the neighborhood(s) surrounding its location.

206. Shopping Districts: A group of 30 or more shops, retail stores, or restaurants usually grouped along a street or within a neighborhood typically spanning two or more contiguous blocks.

207. Neighborhoods: A residential community which is organized in a formal association that meets a minimum of 4 times a year. A residential neighborhood that is organized under a formal adopted plan or neighborhood association that meets four times a year. Neighborhoods receive only a DIST.1a or DIST.1b sign, no directional signage.

300. CULTURAL/INSTITUTIONAL

301. Arenas: Includes stadia, auditoriums and civic or convention centers.

302. Colleges or Universities: An educational institution that is nationally accredited, grants degrees at the associates, bachelor, professional, masters, and/or doctoral levels, and that has a physical campus of at least 5 acres. (*Campus signage is the responsibility of the destination.*)

303. Hospitals: An institution providing primary health services and medical or surgical care to persons, primary inpatients, suffering from illness, disease, injury, deformity and other abnormal physical or mental conditions. The facility must have 24-hour emergency care with a doctor on duty at all times. (*Campus signage is the responsibility of the destination.*)

304. Institutions: A center operated by a municipal, county, state, or federal government unit that is open to the public.

305. Libraries: A repository for literary and artistic materials, such as books, periodicals, newspapers, recordings, films, and electronic media, kept and systemically arranged for use and reference operated either by the City of Austin or by a non-profit organization. Private Media outlets (e.g. Book Stores, Best Buy, etc.) do not qualify under this definition.

306. Museums: A facility in which works of artistic, historical, or scientific value are cared for and exhibited to the General public. (*Campus signage is the responsibility of the destination.*)

307. Observatories: A facility designed and equipped to observe astronomical, meteorological or other natural phenomena.

308. Theatres, Performing Arts, and Concert Halls: Any not-for profit facility used for the public's enjoyment of the performing arts that has a minimum occupancy capacity of 200 people and associated parking.

400. HISTORICAL/ARCHITECTURAL

401. Historic Sites: A structure or place of historical, archaeological or architectural significance listed on or eligible for listing on the National Register of Historic Places maintained by the U.S. Department of Interior or otherwise designated by

the City of Austin. The site must be accessible to the general public and provide a place where visitors can obtain information about the historic site.

Historic Sites may include the following types, provided they meet the above criteria:

- Houses
- Commercial buildings
- Farms, farmsteads and barns
- Religious sites, places of worship, cemeteries and monuments
- Bridges
- Bayous
- Railroad Stations
- Waterbodies

402. Historic Districts: A district or zone listed on or eligible for listing on the National Register of Historic Places maintained by the U.S. Department of Interior or otherwise designated by the City of Austin. Historic districts may provide the general public with a single, central location such as a self-service kiosk or welcome center, where visitors can obtain information concerning the historic district.

Historic Districts may include, but not be limited to, the following:

- Historic residential streets
- Shopping streets and districts
- Courthouses and public buildings
- Landmarks
- Buildings of architectural, design, or artistic merit

403. Architectural Districts: A district or area that has a significant concentration of buildings that are exemplary examples of a particular architectural style as determined by the City. Often architectural districts may be the focus of walking or motor tours.

500. RECREATIONAL

501. Beaches, Piers & Waterfronts: Areas with access to and views of the rivers, streams, and lakes which are recognized by the City, county, or state as having significant recreational or cultural value and are open to the public a minimum of 180 days per calendar year.

502. Boat Launches: A public facility for the launching of boats and parking of motor vehicles and trailers.

503. Canoeing, Rafting, and Kayaking: Public areas with established canoeing, rafting, and/or kayaking facilities. Individual private facilities are not eligible for signage.

504. Golf Courses: A golf facility open to the public and offering at least nine (9) holes of play. Miniature golf courses, driving ranges, chip and putt-putt courses, and indoor golf shall not be eligible.

505. Hiking and Biking Trails/Routes: Areas designated for recreational hiking, biking, walking, etc. and their connections which are publicly accessible, and owned and maintained by either the Local or County government or the State Department of Conservation and Natural Resources, or non-profit organizations. Signs will only be installed at locations that direct the motorist to an established trailhead with parking facilities.

506. Hunting and Fishing Areas: Areas so designated and under the jurisdiction of the State Department of Agriculture and Consumer Services, Department of Environmental Protection, or the Texas Department of Fish and Game.

507. Parks: National, State, Regional and Forests: An area so designated and under the jurisdiction of the state Department of Natural Resources, State Historical Commission, National Park Service, U.S. Department of the Interior, county government, or non-profit organization with facilities open to the general public.

508. Parks – County: An area so designated and under the jurisdiction of the Austin County government with facilities open to the general public.

509. Parks – City: An area so designated and under the jurisdiction of the City of Austin with facilities open to the general public and with enough amenities that its appeal is broader than a particular neighborhood or singular district.

510. Sports Facilities: Regional (multi-jurisdictional) facilities such as minor league and little league baseball fields, youth athletic fields, BMX courses, skateboard parks, etc. *Recreational fields associated with K-12 schools are not considered a part of this system.*

600. TOURIST SERVICES

601. Scenic Overlooks: An area, usually at the side of the road, where persons can observe a scenic area such as significant geology, unique botanical resources, or across expanses of land or water.

602. Visitor Information Centers: A facility where the primary purpose of its operation is to provide information and tourist supportive services. Adequate parking must be provided to support such center.

700. TRANSPORTATION

701. Airports: A public use facility licensed by the TxDOT Right-of-Way (ROW) for landing and takeoff of aircraft and for receiving and discharging passengers and cargo. *(Airport site signage is the responsibility of the destination.)*

702. Heritage Roads, Historic Routes and Trails: A road, trail, or route designated by TxDOT Right-of-Way (ROW), United States Department of the Interior, or other Federal agency as being part of a national or state recognized historic or heritage park/trail system. Bike paths are not eligible for signage under this system.

703. State Highways: A state designated, limited access highway.

704. Parking Lots, Garages & Decks: A parking facility for public parking. These include all City or privately owned lots. Fees may or may not be charged for parking.

705. Water Tours: A guided tour on a body of water using a passenger-carrying vessel with access to a docking facility and adequate legal parking. Eligible for Tier 4 inclusion only.

706. Segway/Bike Tours: A guided tour on a Segway or bike led by a professionally trained guide. Eligible for Tier 4 inclusion only.

CRITERIA RANKING SYSTEM

The Criteria Ranking System sets up a tiered system with specific attributes aimed at determining which Wayfinding tools are appropriate for a destination. The Criteria Ranking System begins with Tier 1, the most visible and highly prescriptive of the Wayfinding tools (i.e. vehicular signage with specific type face and message requirements) and moves down to destinations that can be accommodated by more general wayfinding tools such as pedestrian signs, orientation maps, websites, and brochures.

Once a destination is determined to fall into a particular Tier, that destination is eligible for wayfinding prescribed in that Tier and all subsequent Tiers. For example, destinations eligible for Tier 2 wayfinding are also eligible for Tiers 3 and 4, but not Tier 1. Please note that privately owned and maintained entities are not eligible for inclusion in the Tier system. Destinations with an associated Visitor's Center are automatically included.

● STEP 2: DETERMINE DESTINATION'S WAYFINDING TIER
 To determine the destination's tier it must be ranked using the objective criteria outlined below.

TIER 1: Vehicular Signs/ Primary

These are identified as major destinations and receive directional information to their locations on vehicular signs from a large radius throughout downtown and its major routes. These destinations are typically nationally recognized or serve as a primary visitor function (i.e. visitors center or convention center). These destinations also typically have a designated parking facility or significant accessible parking nearby.

(Must meet 6 out of 7 criteria attributes listed below)

- Nationally Recognized Destination
- Governmental, Historical, or Cultural Institution
- Greater than 50,000 visitors per year
- Open a minimum of 48 hours per week.
- Open 12 months a year
- Includes a Visitor Information Center or Manned Kiosk
- Majority of Visitors not local to the Austin MSA

TIER 2: Vehicular Signs/ Secondary

This tier of secondary destinations receive directional information to their destination on vehicular signs from a smaller radius surrounding their locations. Typically this is limited to the decision points located closest to the point of interest. These are generally recognized destinations that have access to public parking nearby.

(Must meet 3 out of the 4 attributes listed below)

- Regionally Recognized Destination
- Greater than 10,000 visitors per year
- Open at least 40 hours per week
- Open at least 9 months out of the year

*Bridges accommodating motorized vehicles are automatically included in Tier 2.

TIER 3: Pedestrian Signs

Destinations included at this level receive directional information to the destination on pedestrian signs. Information directing to their destination is generally placed within a 5-10 min walking distance. Destinations limited to this tier are primarily access via non-motorized vehicles or offer non-motorized activity (i.e. trails, skate park, BMX park). These destinations are generally local attractions or activities.

(Must meet 2 out of the 2 attributes listed below)

- Locally Recognized Destination
- Primarily accessed via non-motorized vehicle

*Bridges accommodating only non-motorized vehicles are automatically included in Tier 3.

TIER 4: Maps and/or Electronic

This tier captures a variety of public entities or amenities that do not meet the attributes outlined in Tier 1 through 3.



The Downtown Austin Wayfinding Graphics Manual provides information and easy-to-follow directions for ordering signs.

The following components will assist you in ordering new or replacement signs.

1. Estimated Size of Project
(Reference Order Process Chart)
2. Estimated Cost or Budget
(Reference Pricing Worksheet Chart)
3. Determine Sign Types required
(Reference Menu of Sign Types and Design Intent Drawings)
4. Utilize sample Message Schedule to list sign types and messages
5. Receive approval of Messages and Terminologies from End user
6. Submit information to COA Transportation Department and COA Public Works Department for review and approval.

All Signs included in this manual are in compliance with ADA requirements established as of the date of publication.

All graphic components, colors, and typefaces must be used consistently in all signs.

For wayfinding projects it is important that the wayfinding information hierarchy be utilized and that these decisions and approvals be made prior to ordering signs.

The Ordering form below can be obtained by contacting the COA Transportation Department or on their website.

THE ORDERING PROCESS

DOWNTOWN AUSTIN WAYFINDING PROGRAM										ORDER FORM	
REQUESTOR INFORMATION					CHECKLIST						
Contact: _____					<input type="checkbox"/> Sign Type: _____						
Address: _____					<input type="checkbox"/> Manual. Pgs. _____						
Tel: _____					<input type="checkbox"/> Message: see below						
Email: _____					<input type="checkbox"/> Location: see below						
Existing Destination YES NO					<input type="checkbox"/> Loc. Photo: see below						
CRITERIA FOR INCLUSION INFORMATION											
Existing Dest. YES NO					LOCATION PHOTO						
Category: _____					<div style="border: 2px solid black; width: 100%; height: 100%; display: flex; align-items: center; justify-content: center;"> INSERT PHOTO OF PROPOSED LOCATION </div>						
Inclusion Tier: <input type="checkbox"/> 1 <input type="checkbox"/> 2 <input type="checkbox"/> 3 <input type="checkbox"/> 4											
Address: _____											
ORDER											
SCOPE						PARTS					
SIGN TYPE	REPAIR	REPLACE	UPDATE	NEW	POLE	PANEL	MESS.	BRACKET	SIGN	MAP	
ex. VDIR.3				1					1		
TOTALS					0	0	0	0	1	0	
MESSAGE						LOCATION					
COPY			ARROW			DRAWING / INTERSECTION / PLACEMENT					
<i>example</i>											
Library			>			<div style="border: 2px solid black; width: 100%; height: 100%;"></div>					
City Hall			<								
Convention Center			<								
COMMENTS / ADDITIONAL INFO											

DRAFT: 6.17.13											

Example of Ordering Form

This page is intentionally left blank.



section 2

GRAPHIC SIGN STANDARDS

PART A: Design Standards 2.0

- 2.1 Typefaces
- 2.3 Colors & Materials
- 2.6 Pictograms
- 2.8 Terminology
- 2.10 Sign Placement Guidelines
- 2.12 TXDOT Guidelines for Wayfinding
- 2.17 Street Sign Guidelines

PART B: Signage Drawings 2.18

- 2.20 Menus of Sign Types
- 2.31 District Gateway Sign Drawings
- 2.41 Vehicular Sign Drawings
- 2.69 Parking Sign Drawings
- 2.91 Pedestrian Sign Drawings
- 2.117 Trail Sign Drawings

PART C: Construction Details 2.141

- 2.142 Artistic Components & Finials
- 2.143 Various Sign Details
- 2.159 Footer Details

PART A: Design Standards

Project Typefaces

Typeface A - Clearview Hwy (FOR VEHICULAR USE)

ABCDEFGHIJKLMNOPQRSTUVWXYZ
abcdefghijklmnopqrstuvwxyz
1234567890

Typeface B - Helvetica Neue Thin (FOR PEDESTRIAN USE)

ABCDEFGHIJKLMNOPQRSTUVWXYZ
abcdefghijklmnopqrstuvwxyz
1234567890

Typeface C - Helvetica Neue Condensed (FOR PEDESTRIAN USE)

ABCDEFGHIJKLMNOPQRSTUVWXYZ
abcdefghijklmnopqrstuvwxyz
1234567890

Typeface D - Helvetica Neue Bold (FOR PEDESTRIAN USE)

ABCDEFGHIJKLMNOPQRSTUVWXYZ
abcdefghijklmnopqrstuvwxyz
1234567890

TYPOGRAPHY & TYPEFACES

This page provides a reference for the typefaces for the Downtown Austin Wayfinding Signage System.

Typefaces may not be changed. During fabrication, the height and width ratio of letter forms must be maintained proportionately.

Vehicular Signage:
Typeface for vehicular signs is Clearview Hwy. Signs placed on roads with a speed limit of over 25MPH shall have 6" high type. Signs placed on roads with a speed limit of 25MPH and lower shall have 4" high type. Type may be upper and lower case.

Pedestrian Signage:
1" high copy is recommended for overhead pedestrian directional signs.

**TYPOGRAPHY &
TYPEFACES**

This page provides a reference for the typeface recommended for the Downtown Austin Wayfinding Signage System.

Typefaces may not be changed. During fabrication, the height and width ratio of letter forms must be maintained proportionately.

Typeface E - Rockwell Bold (FOR PEDESTRIAN USE)

ABCDEFGHIJKLMNOPQRSTUVWXYZ
abcdefghijklmnopqrstuvwxyz
1234567890

Typeface F - Trajan Regular (FOR PEDESTRIAN USE)

ABCDEFGHIJKLMNOPQRSTUVWXYZ
ABCDEFGHIJKLMNOPQRSTUVWXYZ
1234567890

Paint Colors

	Name	Specification	Process
	P1 Indiglo	To match PMS 296	Surface applied, exterior sign paint and protective top coat: Acrylic Polyurethane w/ Clear Coat Satin finish.
	P2 Cook Islands Blue	To match PMS 661	Surface applied, exterior sign paint and protective top coat: Acrylic Polyurethane w/ Clear Coat Satin finish.
	P3 Yellow Hibiscus	To match PMS 122	Surface applied, exterior sign paint and protective top coat: Acrylic Polyurethane w/ Clear Coat Satin finish.
	P4 Crock Pot Green	To match PMS 5787	Surface applied, exterior sign paint and protective top coat: Acrylic Polyurethane w/ Clear Coat Satin finish.
	P5 Blue Spektor	To match PMS 5493	Surface applied, exterior sign paint and protective top coat: Acrylic Polyurethane w/ Clear Coat Satin finish.
	P6 Camille Blue	To match PMS 2925	Surface applied, exterior sign paint and protective top coat: Acrylic Polyurethane w/ Clear Coat Satin finish.
	P7 Green Lantern	To match PMS 7483	Surface applied, exterior sign paint and protective top coat: Acrylic Polyurethane w/ Clear Coat Satin finish.
	P8 Mozart Blue	To match PMS 444	Surface applied, exterior sign paint and protective top coat: Acrylic Polyurethane w/ Clear Coat Satin finish.
	P9 Red Rage	To match PMS 187	Surface applied, exterior sign paint and protective top coat: Acrylic Polyurethane w/ Clear Coat Satin finish.
	P10 Brownian Gray	To match PMS 411	Surface applied, exterior sign paint and protective top coat: Acrylic Polyurethane w/ Clear Coat Satin finish.
	P11 Dark Red	To match PMS 7526	Surface applied, exterior sign paint and protective top coat: Acrylic Polyurethane w/ Clear Coat Satin finish.
	P12 White	To match PMS White	Surface applied, exterior sign paint and protective top coat: Acrylic Polyurethane w/ Clear Coat Satin finish.
	P13 Silver	To match Silver accents at City Hall	Surface applied, exterior sign paint and protective top coat: Acrylic Polyurethane w/ Clear Coat Satin finish.
	P14 Gray	To match PMS Cool Gray 11	Surface applied, exterior sign paint and protective top coat: Acrylic Polyurethane w/ Clear Coat Satin finish.

COLORS & MATERIALS

Consistent use of a color palette creates a recognizable “system”.

The Color Palette found on the following pages provides a reference for specifying a paint color or material.

The Fabricator is required to submit painted color chips and material samples for approval prior to sign fabrication.

The ADA requires a minimum of 70% contrast between text and background for the legibility.

COLORS & MATERIALS

These vinyls are reflective, meeting MUTCD guidelines for vehicular guide signs.

Vinyl

	Name	Specification	Process
	R1 Indiglo	To match PMS 296	Background & Characters 3M custom inks applied directly to 3930 with 3M approved clear UV/Graffiti Vinyl Over-laminates.*
	R2 Cook Islands Blue	To match PMS 661	Background & Characters 3M custom inks applied directly to 3930 with 3M approved clear UV/Graffiti Vinyl Over-laminates.*
	R3 Yellow Hibiscus	To match PMS 122	Background & Characters 3M custom inks applied directly to 3930 with 3M approved clear UV/Graffiti Vinyl Over-laminates.*
	R4 Crock Pot Green	To match PMS 5787	Background & Characters 3M custom inks applied directly to 3930 with 3M approved clear UV/Graffiti Vinyl Over-laminates.*
	R5 Blue Spektor	To match PMS 5493	Background & Characters 3M custom inks applied directly to 3930 with 3M approved clear UV/Graffiti Vinyl Over-laminates.*
	R6 Camille Blue	To match PMS 2925	Background & Characters 3M custom inks applied directly to 3930 with 3M approved clear UV/Graffiti Vinyl Over-laminates.*
	R7 Green Lantern	To match PMS 7483	Background & Characters 3M custom inks applied directly to 3930 with 3M approved clear UV/Graffiti Vinyl Over-laminates.*
	R8 Mozart Blue	To match PMS 444	Background & Characters 3M custom inks applied directly to 3930 with 3M approved clear UV/Graffiti Vinyl Over-laminates.*
	R9 Red Rage	To match PMS 187	Background & Characters 3M custom inks applied directly to 3930 with 3M approved clear UV/Graffiti Vinyl Over-laminates.*
	R10 Brownian Gray	To match PMS 411	Background & Characters 3M custom inks applied directly to 3930 with 3M approved clear UV/Graffiti Vinyl Over-laminates.*
	R11 Dark Red	To match PMS 7526	Background & Characters 3M custom inks applied directly to 3930 with 3M approved clear UV/Graffiti Vinyl Over-laminates.*
	R12 White	To match PMS White	Background & Characters 3M custom inks applied directly to 3930 with 3M approved clear UV/Graffiti Vinyl Over-laminates.*







*MUST comply with MUTCD section Table 2A-3 – Minimum maintained retroreflectivity levels.

Approved Process: Durst RHO 161 TS printer. Sherine Industries: (604) 513-1887

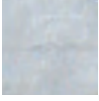
NOTE: All 3M products are to be processed and applied according to 3M specifications. The seaming of material is NOT preferred. If the height of a sign panel is greater than 48 inches, the 3M 3930 material should be oriented vertically with stripes at 0 degrees, to avoid the seaming of material. If seaming is required, it should occur at the rule line or between messages.

COLORS & MATERIALS

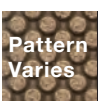
Materials

	Name	Specification	Process
	M1 Concrete	COA Standard Concrete Specifications	Formed & Finished
	M2 Texas Limestone	Local Standard to match COA Sample	N/A
	M3 Graphic Panel	Product: iZone Product or equal	Embedded Phenolic Resin Panel
	M4 Interactive Element	Touchscreen Monitor	N/A
	M5 Banner	18 oz. Opaque White Vinyl	Digital Print
	M6 Decorative Pattern/Material Handcrafted	See PART C: Construction Details, page 2.142 for more details	Various
	M7 Cast Panel	Cast panel embedded in concrete/brick sidewalk	Cast and Filled Zinc Panel

Arrows

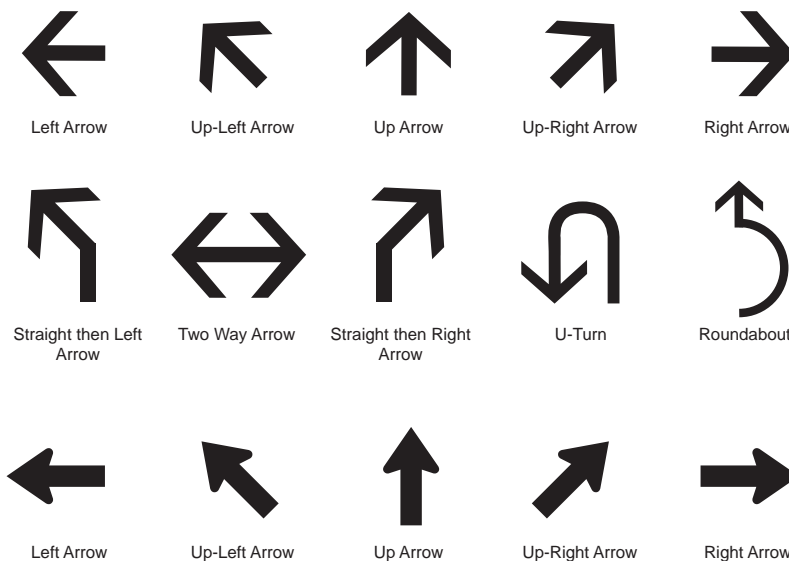

ARROWS

Arrows for signs NOT on TXDOT roads

Arrows approved for signs on TXDOT roads

PICTOGRAMS

Pictograms contribute simplicity, clarity and personality to a system. They do not require translation and can communicate across various forms of media, especially signage. They are an effective way of identifying physical elements, services or procedures.

Benefits of pictograms:

- Understandable
- Memorable
- Common Language
- Distinguishable
- Character
- Expandable

Pictograms are used only to direct to primary destinations as identified in the Criteria for Destination Inclusion. Different versions of the primary icons will be used on various wayfinding elements.

These icons represent:

- The Capitol
- University of Texas
- Convention Center
- South Congress
- Public Parking
- Information
- 6th Street

Primary Pictograms - Vehicular & Pedestrian

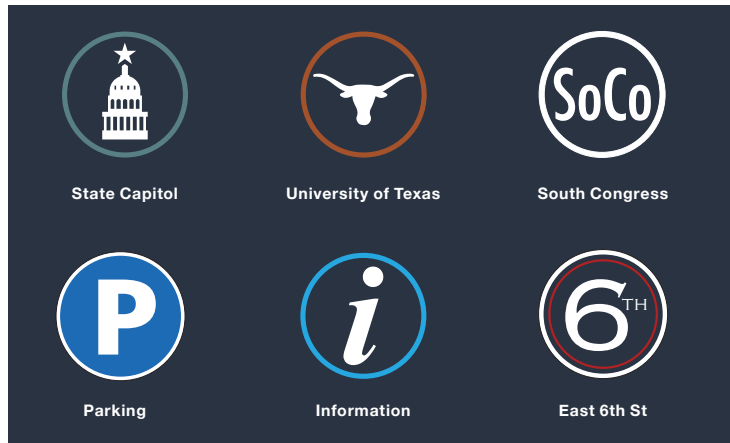

Primary Pictograms - full-color (maps, web usage)

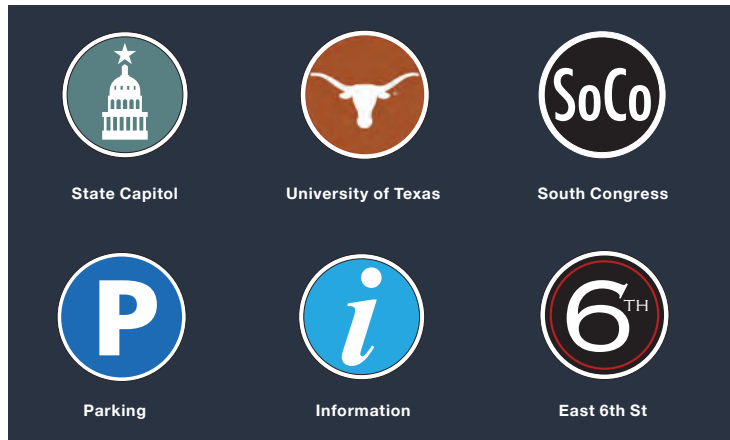

Primary Pictograms - 1-color (for temporary signage)

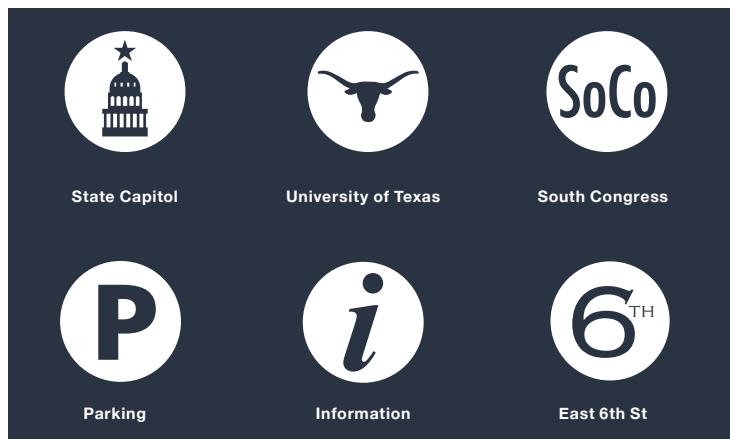

AMENITIES



Food
A1



Shopping
A2



ATM
A3

TRANSPORTATION/ ACCESS SET



Bus
B1



Metrorail
B2



Bike Path
B3



Pedestrian Trail
B4



Water Access
B5



Bike Share
B6



Taxi
B7

TECHNOLOGY



Wireless Hot Spot
C1



Downloads
C2



Solar Power
C3

INFORMATION



Smartphone Info
D1



Pedestrian Info
D2



Bike Info
D3



Information
D4

REGULATORY



No Bikes
Allowed
E1



No Dogs Allowed
E2



Skateboarding
Not Allowed
E3



Swimming
Not Allowed
E4



Rollerblading
Allowed
E5



Dogs Allowed
E6



Bikes Allowed
E7



Pedestrians Allowed
E8

DESTINATIONS



Family-Friendly
F1



Music Venue
F2

PICTOGRAMS

Amenities Pictograms will be found on Pedestrian wayfinding elements such as Kiosks, Trail and Temporary Signage and maps.

Benefits of pictograms:

- Understandable
- Memorable
- Common Language
- Distinguishable
- Character
- Expandable

**TERMINOLOGY
VEHICULAR SIGNAGE**

Destinations listed at right will be signed to on vehicular signs. Colors correspond with the chart on the following page and the Criteria for Inclusion on page 1.9 of this manual.

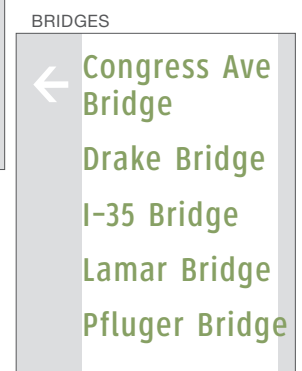
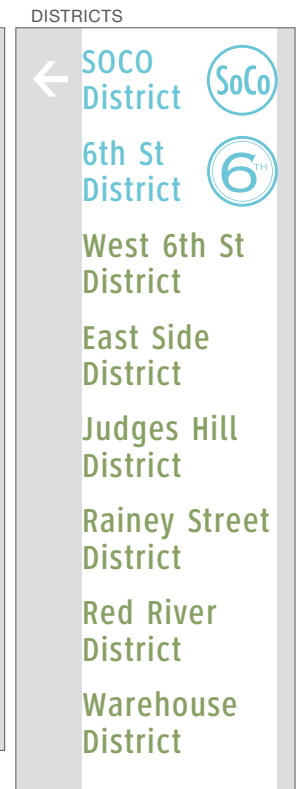
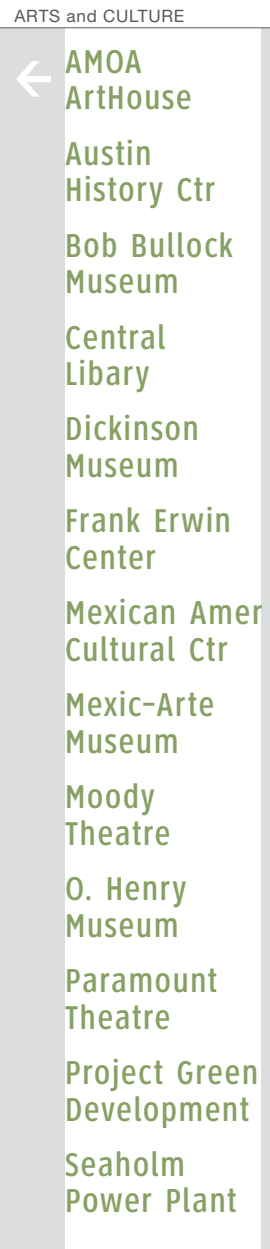
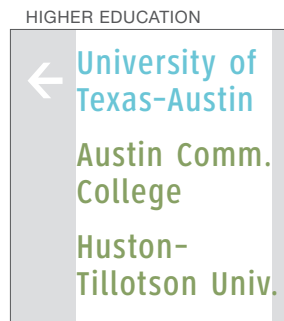
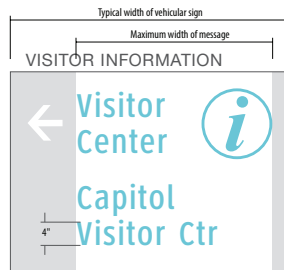

Typical width of vehicular sign
Maximum width of message

VISITOR INFORMATION

Austin Visitor Center
MINUTES

Capitol Visitor Center
MINUTES

VISITOR INFORMATION

Convention Center

ATT Center

HIGHER EDUCATION

University of Texas-Austin

Austin Community College

GOVERNMENT

Faulk Library

City Hall

Federal Courthouse

Governors Mansion

Municipal Court

Post Office

State Capitol

Travis County Courthouse

TX Supreme Court Hist Soc

ARTS and CULTURE

The Contemporary Austin

Austin History Center

Bullock State Hist. Museum

Mexic-Arte Museum

O. Henry Museum

S. Dickinson Museum

Paramount Theatre

Mexican Amer. Cultural Ctr

Green Development

Seaholm Power Plant

Frank Erwin Center

Moody Theater

ADJACENT ATTRACTIONS

Blanton Museum

Dougherty Arts Center

French Legation Museum

Carver Museum & Cult Ctr

Huston-Tillotson University

Long Center for Perf. Arts

Palmer Events Center

State Cemetery

Zach Theatre

The UT Drag

Pfluger Pedestrian Bridge

PARKS and RECREATION

Recreation Center

Centennial Park

Duncan Park

House Park

Skate Park

Lady Bird Lake

Palm Park

Shoal Creek Greenway

Waller Creek Greenway

Waterloo Park

Butler Park

Norwood Park

9th Street BMX Park

Auditorium Shores

WC Boathouse

TRAILS

Butler Hike & Bike Trail

Lance Armstrong Bikeway

Shoal Creek Trail

Waller Creek Trail

SHOPPING DISTRICTS

2nd Street District

6th and Lamar

Congress Ave District

DISTRICTS

2nd St District

West 6th St District

Congress Ave District

Rainey St District

SOCO District

6th St District

West End District

East Side District

Red River District

Warehouse District

Judges Hill District

Uptown/Arts District

BRIDGES

Congress Ave Bridge

Drake Bridge

I-35 Bridge

Lamar Bridge

Pfluger Bridge

SQUARES

Brush Square

Republic Square

Wooldridge Square

HISTORIC/HERITAGE

German Free School

Treaty Oak

The Bremond Block

STATUES

Stevie Ray Vaughn Statue

Willie Nelson Statue

Angelina Eberly Statue

**TERMINOLOGY
PEDESTRIAN SIGNAGE**

Destinations listed at left will be signed to on pedestrian signs. Colors correspond with the chart on the this page and the Criteria for Inclusion on page 1.9 of this manual.

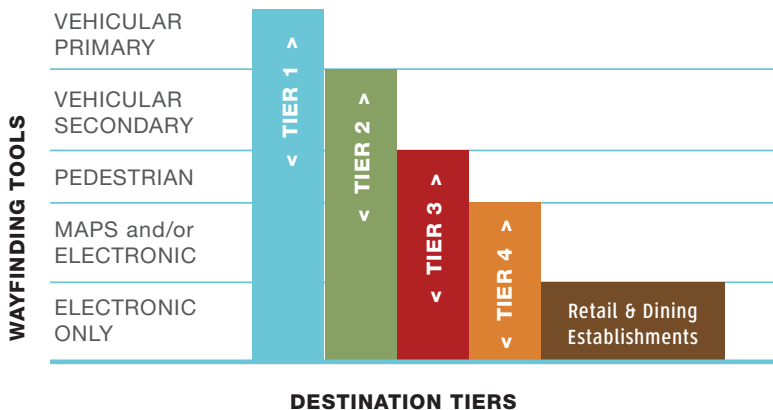

TXDOT GUIDELINES FOR WAYFINDING GUIDE SIGNING

NOTE: These guidelines shall be followed for signage in TXDOT Right-of-way only, NOT for City of Austin (COA) streets.

SECTION 2D.01 SCOPE OF CONVENTIONAL ROAD GUIDE SIGN STANDARDS STANDARD:

01. The provisions of this Chapter shall apply to any road or street other than low-volume roads (as defined in Section 5A.01), expressways, and freeways.

SECTION 2D.02 APPLICATION

Support:

01. Guide signs are essential to direct road users along streets and highways, to inform them of intersecting routes, to direct them to cities, towns, villages, or other important destinations, to identify nearby rivers and streams, parks, forests, and historical sites, and generally to give such information as will help them along their way in the most simple, direct manner possible.

02. Chapter 2A addresses placement, location, and other general criteria for signs.

SECTION 2D.03 COLOR, RETROREFLECTION, AND ILLUMINATION

Support:

01. Requirements for illumination, retroreflection, and color are stated under the specific headings for individual guide signs or groups of signs. General provisions are given in Sections 2A.07, 2A.08, and 2A.10.

Standard:

02. Except where otherwise provided in this Manual for individual signs or groups of signs, guide signs on streets and highways shall have a white message and border on a green background. All messages, borders, and legends shall be retroreflective and all backgrounds shall be retroreflective or illuminated. Support:

03. Color coding is sometimes used to help road users distinguish between multiple potentially confusing destinations. Examples of valuable uses of color coding include guide signs for roadways approaching or inside an airport property with multiple terminals serving multiple airlines, and community wayfinding guide signs for various traffic generator destinations within a community or area.

Standard:

04. Except where otherwise provided in this Manual, different color sign backgrounds shall not be used to provide color coding of destinations. The color coding shall be accomplished by the use of different colored square or rectangular sign panels on the face of the guide signs. Option:

05. The different colored sign panels may include a black or white (whichever provides the better contrast with the panel color) letter, numeral, or other appropriate designation to identify an airport terminal or other destination.

Support:

06. Two examples of color-coded sign assemblies are shown in Figure 2D-1. Section 2D.50 contains specific provisions regarding Community Wayfinding guide signs.



SECTION 2D.04 SIZE OF SIGNS STANDARD:

01. Except as provided in Section 2A.11, the sizes of conventional road guide signs that have standardized designs shall be as shown in Table 2D-1.

Support:

02. Section 2A.11 contains information regarding the applicability of the various columns in Table 2D-1.

Option:

03. Signs larger than those shown in Table 2D-1 may be used (see Section 2A.11).

Support:

04. For other guide signs, the legends are so variable that a standardized design or size is not appropriate. The sign size is

determined primarily by the length of the message, and the size of lettering and spacing necessary for proper legibility.

Option:

05. Reduced letter height, reduced interline spacing, and reduced edge spacing may be used on guide signs if sign size must be limited by factors such as lane width or vertical or lateral clearance.

Guidance:

06. Reduced spacing between the letters or words on a line of legend should not be used as a means of reducing the overall size of a guide sign, except where determined necessary by engineering judgment to meet unusual lateral space constraints. In such cases, the legibility distance of the sign legend should be the primary consideration in determining whether to reduce the spacing between the letters or the words or between the words and the sign border, or to reduce the letter height.

07. When a reduction in the prescribed size is necessary, the design used should be as similar as possible to the design for the standard size.

*Table 2D-1 may be found at the following address:
<http://www.txdot.gov/government/enforcement/signage/tmutcd.html>*

(Chapter 2D - Guide Signs - Conventional Roads PDF)

SECTION 2D.05 LETTERING STYLE STANDARD:

01. The design of upper-case letters, lower-case letters, numerals, route shields, and spacing shall be as provided in the "Standard Highway Sign Designs for Texas" book (see Section 1A.11).

02. The lettering for names of places, streets, and highways on conventional road guide signs shall be a combination of lower-case letters with initial upper-case letters (see Section 2A.13). The nominal loop height of the lower-case letters shall be 3/4 the height of the initial upper-case letter. When a mixed-case legend letter height is specified referring only to the initial upper-case letter, the height of the lower-case letters that follow shall be determined by this proportion. When the height of a lower-case letter is referenced, the reference is made to the nominal loop height and the height of the initial upper-case letter shall also be determined by this proportion.

03. All other word legends on conventional road guide signs shall be in upper-case letters.

04. The unique letter forms for each of the Standard Alphabet series shall not be stretched, compressed, warped, or otherwise manipulated. Modifications to the length of a word for a given letter height and series shall be accomplished only by the methods described in Section 2D.04.

SECTION 2D.06 SIZE OF LETTERING**Support:**

01. Sign legibility is a direct function of letter size and spacing. Legibility distance has to be sufficient to give road users enough time to read and comprehend the sign. Under optimum conditions, a guide sign message can be read and understood in a brief glance. The legibility distance takes into account factors such as inattention, blocking of view by other vehicles, unfavorable weather, inferior eyesight, or other causes for delayed or slow reading. Where conditions permit, repetition of guide information on successive signs gives the road user more than one opportunity to obtain the information needed.

Standard:

02. Design layouts for conventional road guide signs showing interline spacing, edge spacing, and other specification details shall be as shown in the "Standard Highway Sign Designs for Texas" book (see Section 1A.11).

03. The principal legend on guide signs shall be in letters and numerals at least 6 inches in height for all upper-case letters, or a combination of 6 inches in height for upper-case letters and 4.5 inches in height for lower-case letters. On low-volume roads (as defined in Section 5A.01) with speeds of 25 mph or less, and on urban streets with speeds of 25 mph or less, the principal legend shall be in letters at least 4 inches in height for all upper-case letters, or a combination of 4 inches in height for upper-case letters and 3 inches in height for lower-case letters.

Guidance:

04. Lettering sizes should be consistent on any particular class of highway.

05. The minimum lettering sizes provided in this Manual should be exceeded where conditions indicate a need for greater legibility.

SECTION 2D.07 AMOUNT OF LEGEND

Support:

01. The longer the legend on a guide sign, the longer it will take road users to comprehend it, regardless of letter size.

Guidance:

02. Except where otherwise provided in this Manual, guide signs should be limited to no more than three lines of destinations, which include place names, route numbers, street names, and cardinal directions. Where two or more signs are included in the same overhead display, the amount of legend should be further minimized. Where appropriate, a distance message or action information, such as an exit number, NEXT RIGHT, or directional arrows, should be provided on guide signs in addition to the destinations.

used unless an arrow can be located over and pointed to the approximate center of each lane that can be used to reach the destination displayed on the sign.

03. If down arrows are used, having more than one down arrow pointing to the same lane on a single overhead sign (or on multiple signs on the same overhead sign structure) shall not be permitted.

04. Where a roadway is leaving the through lanes, a directional arrow shall point upward at an angle that approximates the alignment of the exit roadway.

Option:

05. Curved-stem arrows (see Figure 2D-8) that represent the intended driver paths to destinations involving left-turn movements may be used on guide signs on approaches to circular intersections.

Standard:

06. Curved-stem arrows shall not be used on any sign that is not associated with a circular intersection.

Guidance:

07. If curved-stem arrows are used, the principles set forth in Sections 2D.26 through 2D.29 should be followed.

08. The Type A directional arrow should be used on guide signs on freeways, expressways, and conventional roads to indicate the direction to a specific destination or group of destinations, except as otherwise provided in this Section and in Section 2E.19.

09. When a directional arrow in a vertical, upward-pointing orientation is placed to the side of a group of destinations to indicate a through movement, the Type A directional arrow should be used. When a directional arrow in a vertical, upward-pointing orientation is placed to the side of a single destination or under a destination or group of destinations, the Type B directional arrow should be used.

10. The Type B directional arrow should be used on guide signs on conventional roads when placed at any angle to the side of a single destination or when placed in a horizontal orientation to the side of a group of destinations.

11. The Type C advance turn directional arrow should be used on conventional road guide signs placed in advance of an intersection where a turn must be made to reach a posted destination or group of destinations.

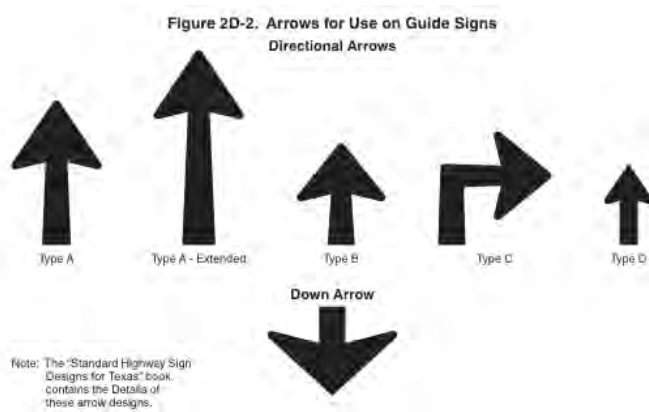

SECTION 2D.08 ARROWS

Support:

01. Arrows are used for lane assignment and to indicate the direction toward designated routes or destinations. Figure 2D-2 shows the various standard arrow designs that have been approved for use on guide signs. Detailed drawings and standardized sizes based on ranges of letter heights are shown for these arrows in the "Standard Highway Sign Designs for Texas" book (see Section 1A.11).

Standard:

02. On overhead signs where it is desirable to indicate a lane to be followed, a down arrow shall be positioned approximately over the center of the lane and shall point vertically downward toward the approximate center of that lane. Down arrows shall be used only on overhead guide signs that restrict the use of specific lanes to traffic bound for the destination(s) and/or route(s) indicated by these arrows. Down arrows shall not be

12. The Type D directional arrow should be used primarily for sign applications other than guide signs, except as provided in Paragraph 16.

Option:

13. The Type A-Extended directional arrow may be used on guide signs where additional emphasis regarding the direction is needed relative to the amount of legend on the sign.

14. The Type C directional arrow may be used to the side of the legend of an overhead guide sign to accentuate a sharp turn exit maneuver from a mainline roadway (see Section 2E.36 for additional information regarding Exit Direction signs for low advisory ramp speeds).

15. On conventional roads on the approach to an intersection where the Combination Lane-Use/Destination overhead guide sign (see Section 2D.33) is not used, the Type C advance turn directional arrow may be used beneath the legend of an overhead guide sign to indicate the fact that a turn must be made from a mandatory movement lane over which the sign is placed to reach the destination or destinations displayed on the sign.

16. The Type D directional arrow may be used on post-mounted guide signs on conventional roads if the height of the text on the sign is 8 inches or less.

17. The directional and down arrows shown in Figure 2D-2 may be used on signs other than guide signs for the purposes of providing directional guidance and lane assignment.

Guidance:

18. Arrows used on guide signs to indicate the directions toward designated routes or destinations should be pointed at the appropriate angle to clearly convey the direction to be taken. A horizontally oriented directional arrow design should be used at right-angle intersections.

19. On a post-mounted guide sign, a directional arrow for a straight-through movement should point upward. Except as provided in Section 2D.46, for a turn, the arrow on a guide sign should point horizontally or at an upward angle that approximates the sharpness of the turn.

20. At an exit, an arrow should be placed at the side of the sign that will reinforce the movement of exiting traffic. The directional arrow design should be used.

Option:

21. Arrows may be placed below the principal sign legend or on the appropriate side of the legend.

22. On a post-mounted sign at an exit where placement of the arrow to the side of the legend farthest from the roadway would create an unusually wide sign that limits the road user's view of the arrow, the directional arrow may be placed at the bottom portion of the sign, centered under the legend.

Guidance:

23. The width across the arrowhead for the Types A, B, and C directional arrows should be between 1.5 and 1.75 times the height of the upper-case letters of the principal legend on the sign. The width across the arrowhead for the Type D directional arrow should be at least equal to the height of the upper-case letters of the principal legend on the sign. For down arrows used on overhead signs, the width across the arrowhead should be approximately two times the height of the upper-case letters of the principal legend on the sign.

24. Arrows used in Overhead Down Arrow, Overhead Arrow-per-Lane and Diagrammatic guide signing, if used on conventional roads, except for signs on approaches to roundabouts, should follow the principles set forth in Section 2E.19. Arrows used in Diagrammatic guide signing on approaches to roundabouts should follow the principles set forth in Section 2D.38.

Support:

25. The "Standard Highway Sign Designs for Texas" book (see Section 1A.11) contains design details and standardized sizes of the various arrows based on ranges of letter heights of principal legends.

This page is intentionally left blank.

PART B:
Signage Drawings

- District Gateways
- Vehicular
- Parking
- Pedestrian
- Trails

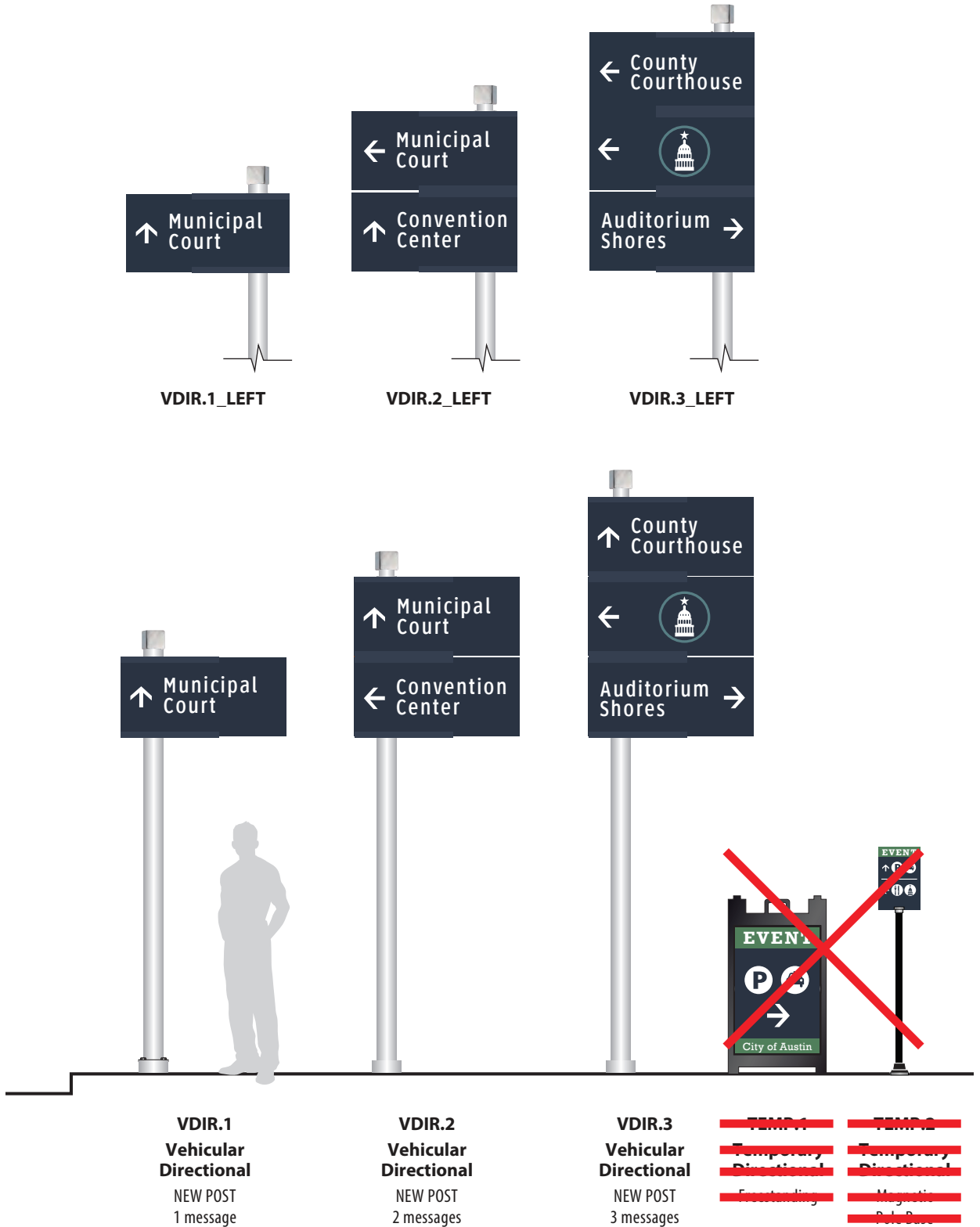



VDIR.6
TXDOT Vehicular Directional
 NEW POSTS / 3 messages

**SIGN MENU:
 VEHICULAR**

VEHICULAR DIRECTIONALS:
 Vehicular directional signs are modular with panels that can be easily replaced. Signs can have 1-3 messages, and can hold either a graphic pictogram message or a text message.

For signs typically used on roadways with a speed limit of 25mph or less, per MUTCD section 2D.50, copy is 4" high, typeface is Clearview and both background and copy are retro-reflective. Sign posts are break-away. "Left-Mounted" versions are available for placement on opposite sides (left) of street.

There are also 3 TXDOT approved sign designs shown, with a different pole and break-away system. These signs have 6" high copy and are located along roads where the speed limit is over 25mph.

TEMPORARY SIGNS:
 Temporary signs can easily be put up on existing poles or set out on sidewalks. A simple organized layout incorporating pictograms is easily read and understood by visitors.

DESTINATION ID SIGNS:
 Destination ID signs utilize design elements from both the Vehicular menu and Pedestrian menu (pg 22.8). The destination and space allotted for a sign will denote which sign is used.



VDIR.4
TXDOT Vehicular Directional
 NEW POST
 1 message



VDIR.5
TXDOT Vehicular Directional
 NEW POSTS
 2 messages



~~**DEST.1**~~
~~**Destination ID**~~
~~**SMALL**~~



~~**DEST.2**~~
~~**Destination ID**~~
~~**LARGE**~~

**SIGN MENU:
PARKING**

Parking directional signs are modular with panels that can be easily replaced. Signs can have 1-3 messages, and can hold either a graphic pictogram message or a text message.

PARKING DIRECTIONALS:
Parking Directional Signs can direct to a lot by name or include the destination the lot serves.

PARKING TRAILBLAZER:
Parking Trailblazer Signs can be mounted to existing lightpoles.

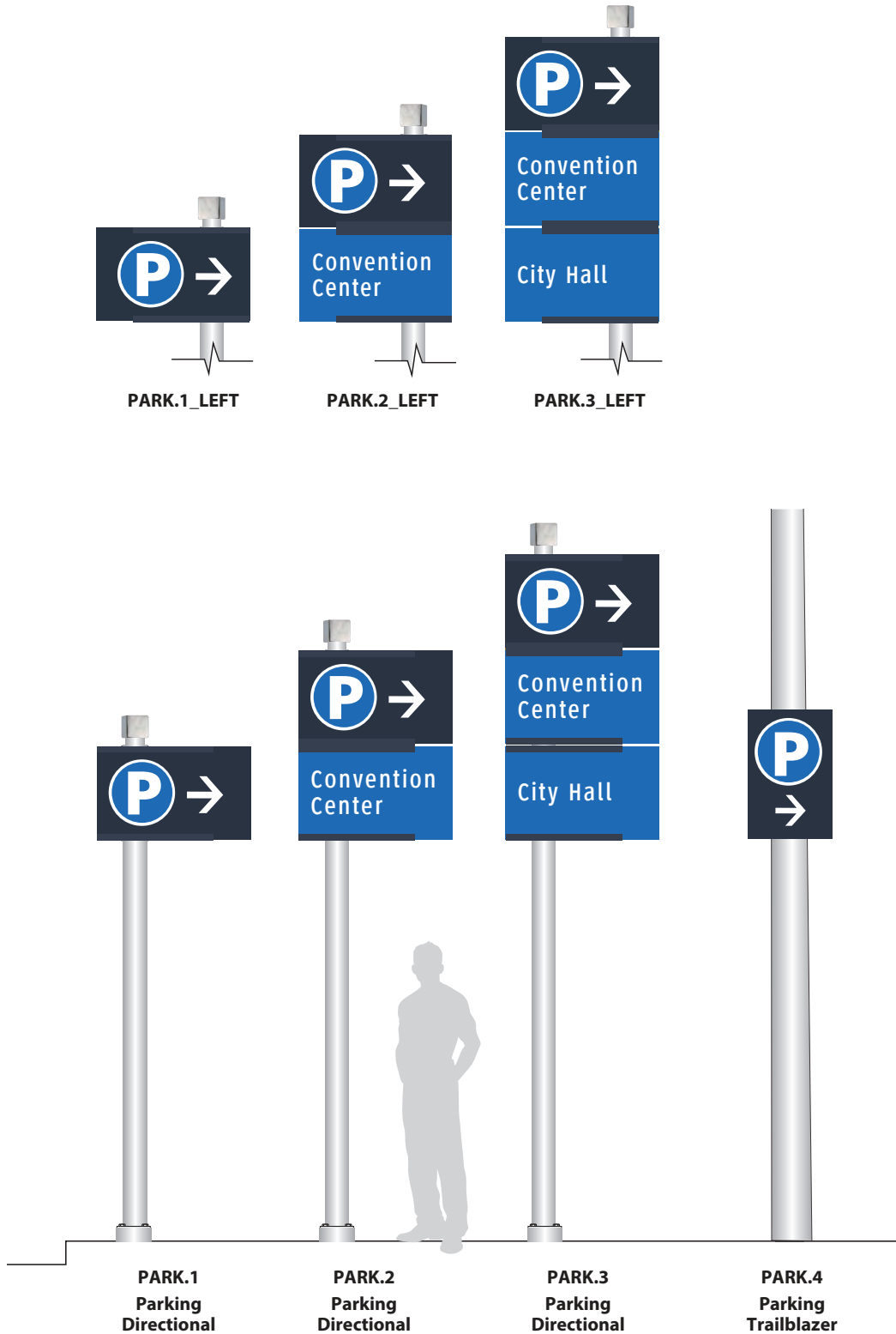

**SIGN MENU:
PEDESTRIAN**

A series of pedestrian sign types have been developed to address various situations and communicate a variety of information.

PEDESTRIAN DIRECTIONALS:
These sign types can be mounted to existing poles or on new poles and provides direction to up to 6 destinations.

In addition to the attraction name and direction, the sign should also indicate the amount of time it takes to walk to that destination. Text or pictograms can be used on the signs.

These signs can direct to typical destinations and attractions as well as parking garages and lots, and adjacent districts.

PEDESTRIAN MAPS:
In situations where orientation would assist a visitor, signs are available to display a map graphic. The "heads-up" map includes major landmarks and a 5 and 10 minute walk radius.

Signs can be mounted on existing posts or freestanding.



PDIR.3	PDIR.3A	PDIR.6	PDIR.6A	PMAP.1	PMAP.2
Pedestrian Directional	Pedestrian Directional	Pedestrian Directional	Pedestrian Directional	Pedestrian Map	Pedestrian Map
Utility Pole Attachment	NEW POST	Utility Pole	NEW POST	Single-Sided Utility Pole Attachment	Double-Sided 2 Posts
3 messages	3 messages	6 messages	6 messages		

**SIGN MENU:
PEDESTRIAN**

INTERPRETIVE PANELS:
Interpretive panels can tell a story about Downtown Austin's history, music scene, or sustainable programs being initiated in the Downtown. They can be located in parks and at key gathering points.

PEDESTRIAN KIOSKS:
Located at key gathering points, kiosks provide even broader information and are substantial, offering directions, maps and in some cases technology access.

These signs are illuminated, have architectural bases and can use solar power. There is also opportunity for local artisans to contribute to these elements.

Kiosk bases located in the Downtown have a Texas Limestone base.

SIDEWALK COMPASS:
Located along main pedestrian streets, these low-profile wayfinding elements are in-laid in the sidewalks to provide basic orientation to visitors.

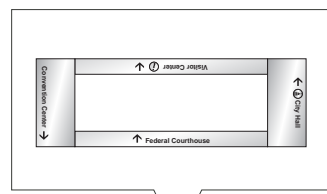

**PDIR.7
Kiosk Directional Plaque**

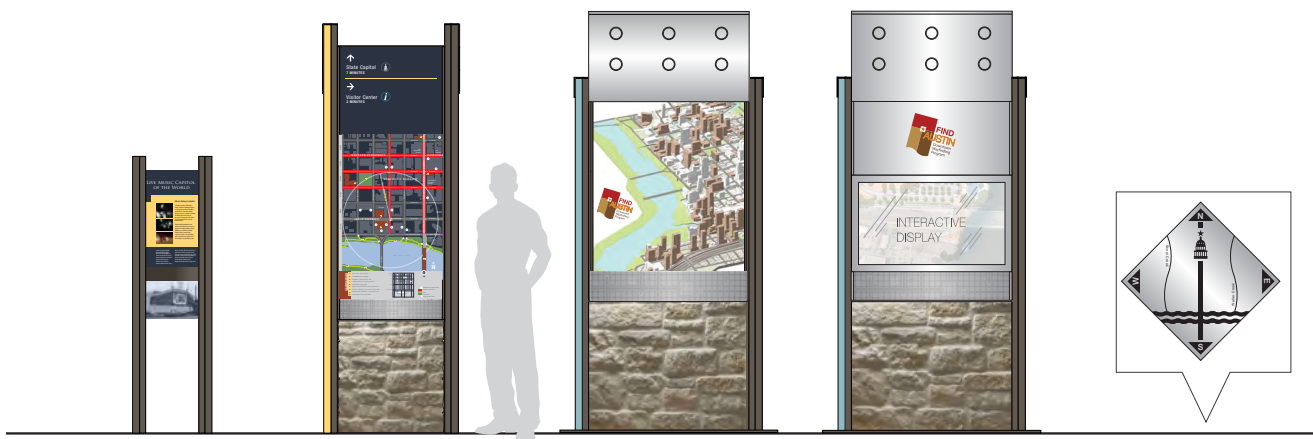

**PINTERP.1
Pedestrian
Interpretive
Single- or
Double-Sided**

**PKIOSK.1
Pedestrian
Directional/Map
Double-Sided**

**PKIOSK.2/3
Pedestrian Kiosk
Static Info
Single-Sided
Stone Base**

**PKIOSK.2A/3A
Pedestrian Kiosk
Digital Info
Double-Sided
Stone Base**

**COMPASS.1
Pedestrian
Sidewalk Compass**

This page is intentionally left blank.

VDIR.1
VEHICULAR DIRECTIONAL

Vehicular directional signs are modular with panels that can be easily replaced. Signs can have 1-3 messages, and can hold either a graphic pictogram message or a text message.

Signs are typically used on roadways that have a speed limit of 25mph or less, per MUTCD section 2D.50 copy is 4" high, typeface is Clearview and both background and copy are retro-reflective. Sign posts are break-away.

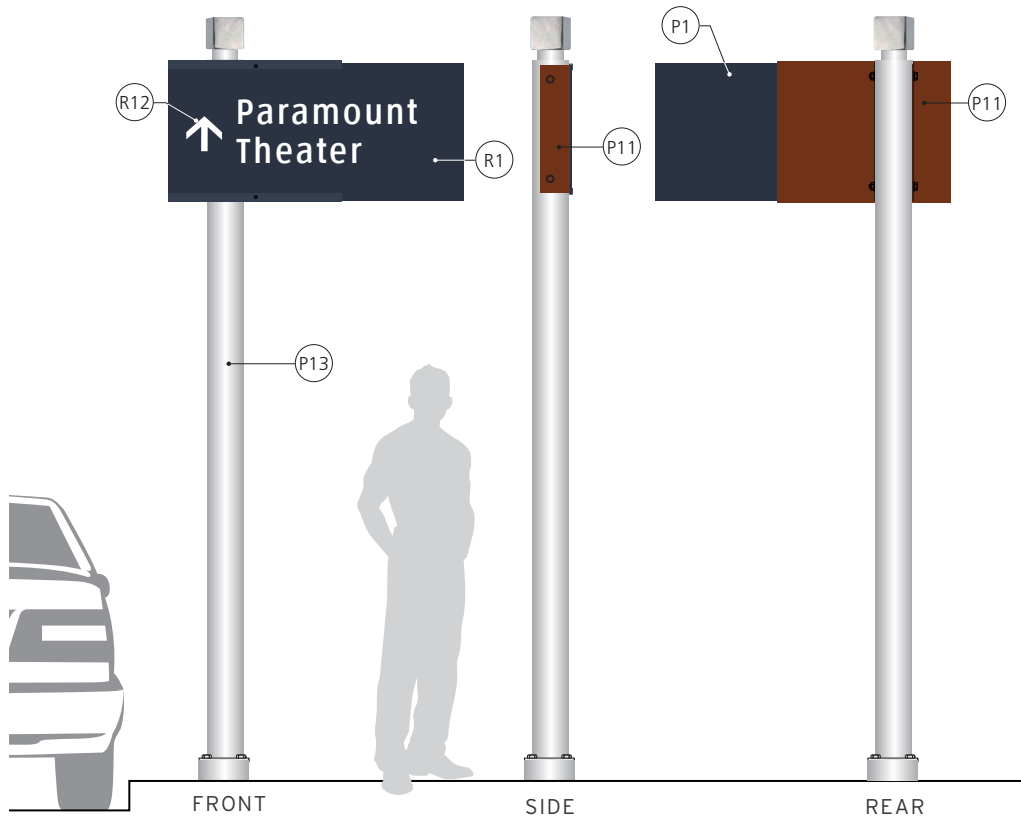

1 Color Schedule VDIR.1
scale: 3/8"=1'-0"

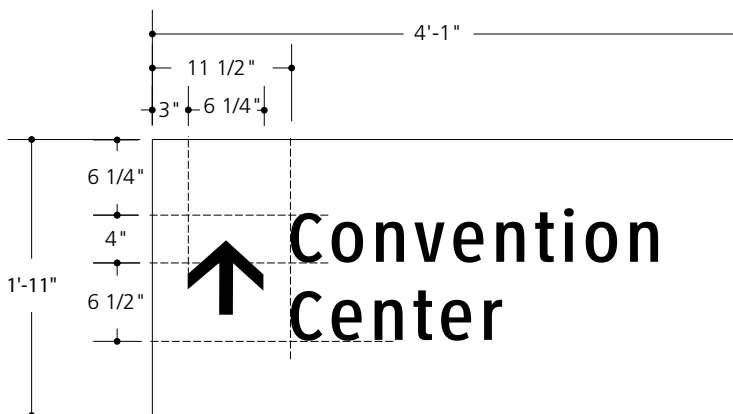

2 Typical Layout Guidelines - 4"
scale: 3/4"=1'-0"

These drawings are meant for DESIGN INTENT ONLY and are not for construction. Contractor shall verify and be responsible for all dimensions and conditions of the job. Contractor shall be familiar with the site and conditions it presents. This office must be notified of any variations from the dimensions and conditions shown on this drawing. Shop drawings and details must be submitted to the City of Austin for approval prior to proceeding with fabrication. All copy shall be proofread by the City of Austin and legal requirements checked by legal department.

VDIR.1
VEHICULAR DIRECTIONAL

All exposed surfaces shall have a anti-graffiti protectant. Painted surfaces will have a clear coating and vinyl surfaces shall have a clear vinyl over-lam as required by the paint and vinyl manufacturer.

All exposed fasteners shall be painted to match adjacent surface.

All sign structures shall be signed and sealed by a certified Texas structural engineer prior to fabrication.

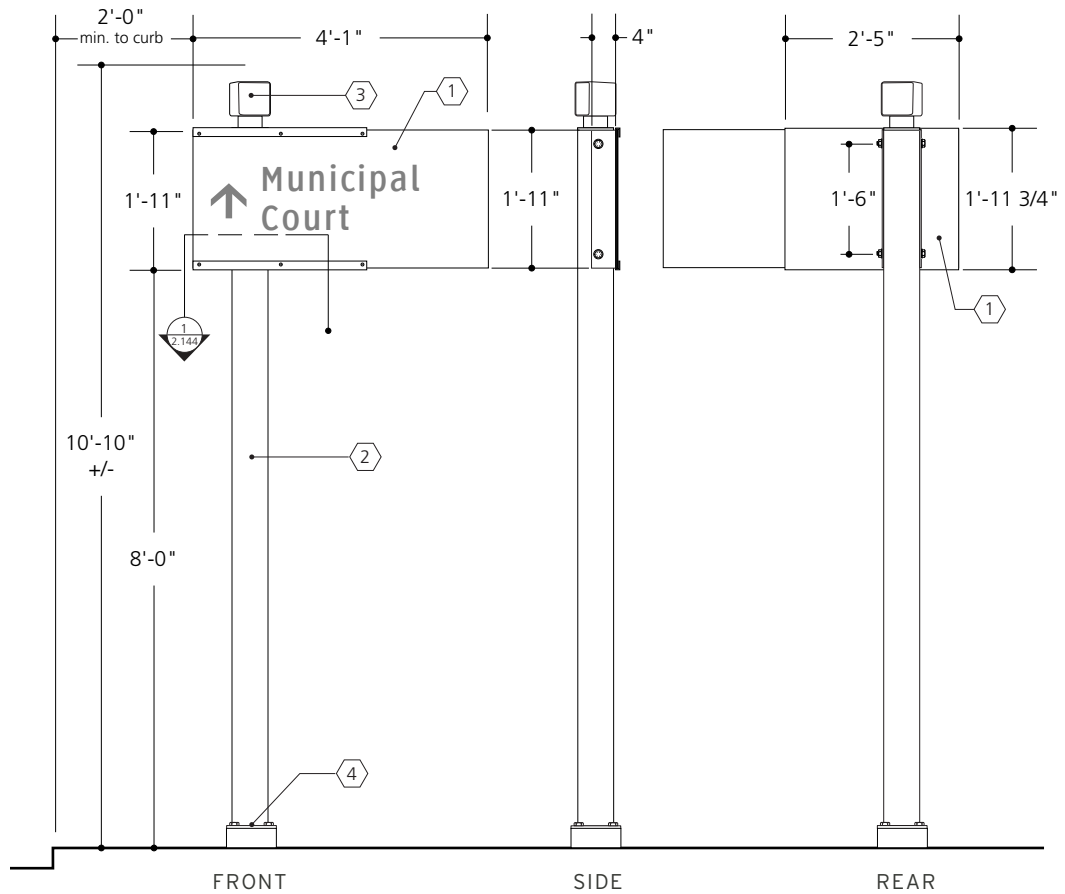

1 Elevations VDIR.1
scale: 3/8"=1'-0"

- ① Modular sign panel assembly (see PART C: Construction Details for more detail)
- ② 6" x 1/4 wall alum tube upright
- ③ Handcrafted finial - mounted to upright cap assembly (see PART C: Construction Details, page 2.143).
- ④ Transpo Pole-Safe breakaway device with aluminum escutcheon cover (see PART C: Construction Details for different footer types). Verify all location conditions.

These drawings are meant for DESIGN INTENT ONLY and are not for construction. Contractor shall verify and be responsible for all dimensions and conditions of the job. Contractor shall be familiar with the site and conditions it presents. This office must be notified of any variations from the dimensions and conditions shown on this drawing. Shop drawings and details must be submitted to this office for approval prior to proceeding with fabrication. All copy shall be proofread by client and legal requirements checked by legal department.

VDIR.1_LEFT
VEHICULAR DIRECTIONAL

Vehicular directional signs are modular with panels that can be easily replaced. Signs can have 1-3 messages, and can hold either a graphic pictogram message or a text message.

Signs are typically used on roadways that have a speed limit of 25mph or less, per MUTCD section 2D.50 copy is 4" high, typeface is Clearview and both background and copy are retro-reflective. Sign posts are break-away.

"Left-Mounted" versions are available for placement on opposite sides (left) of street.

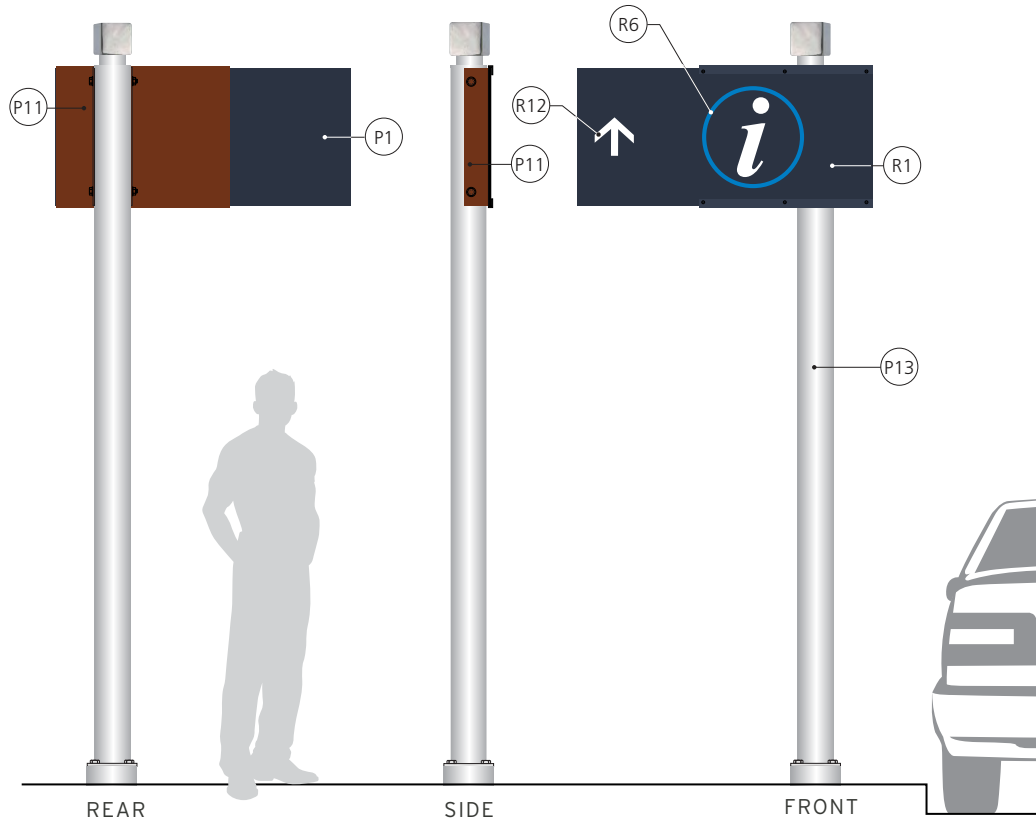

1 Color Schedule VDIR.1_left
scale: 3/8"=1'-0"

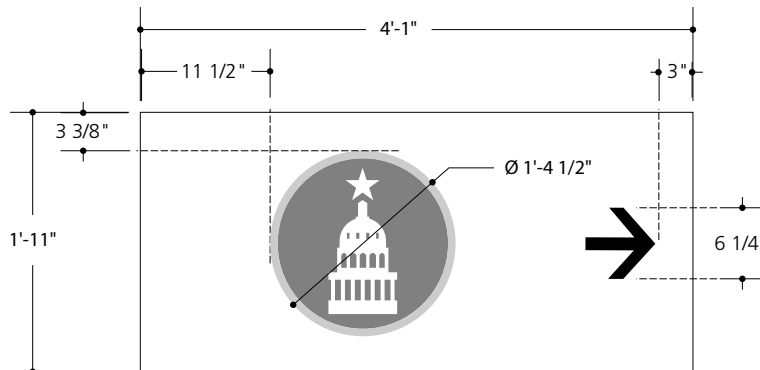

2 Typical Layout Guidelines - Pictogram
scale: 3/4"=1'-0"

These drawings are meant for DESIGN INTENT ONLY and are not for construction. Contractor shall verify and be responsible for all dimensions and conditions of the job. Contractor shall be familiar with the site and conditions it presents. This office must be notified of any variations from the dimensions and conditions shown on this drawing. Shop drawings and details must be submitted to the City of Austin for approval prior to proceeding with fabrication. All copy shall be proofread by the City of Austin and legal requirements checked by legal department.

VDIR.1_LEFT
VEHICULAR DIRECTIONAL

All exposed surfaces shall have a anti-graffiti protectant. Painted surfaces will have a clear coating and vinyl surfaces shall have a clear vinyl over-lam as required by the paint and vinyl manufacturer.

All exposed fasteners shall be painted to match adjacent surface.

All sign structures shall be signed and sealed by a certified Texas structural engineer prior to fabrication.

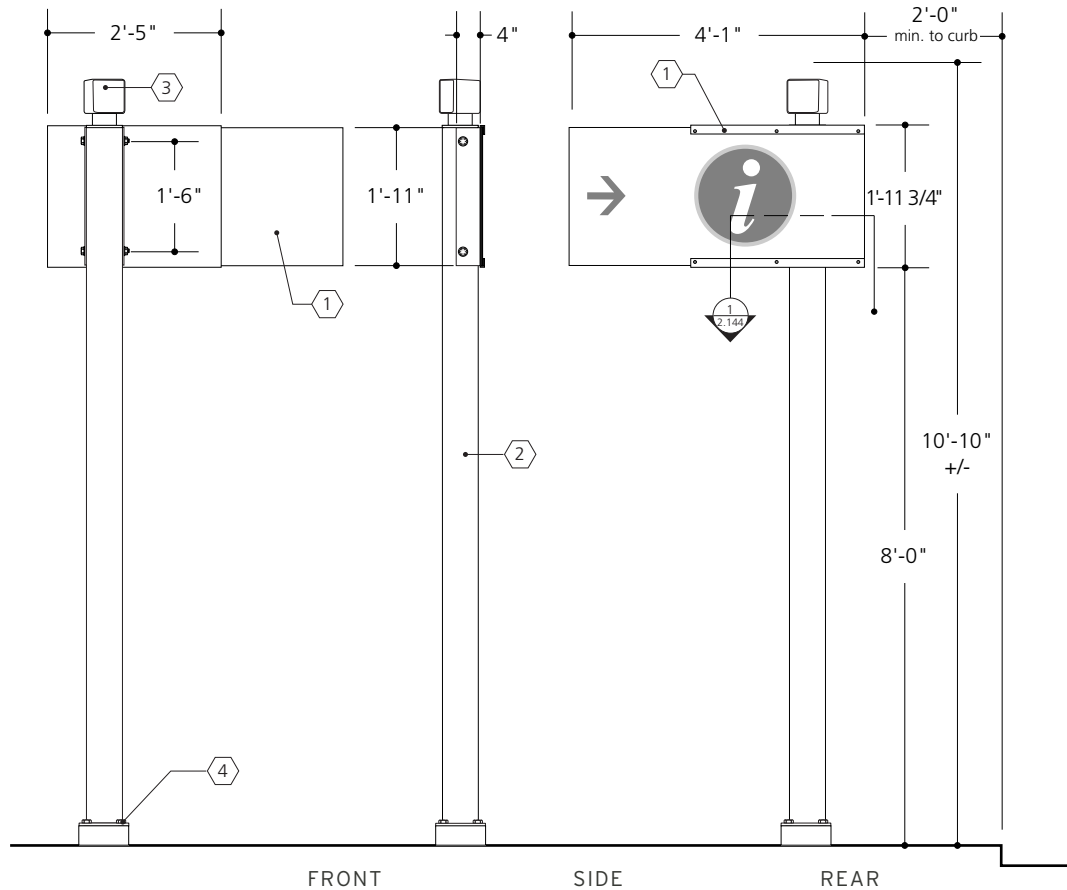

1 Elevations VDIR.1 left
scale: 3/8"=1'-0"

- ① Modular sign panel assembly (see PART C: Construction Details for more detail)
- ② 6" x 1/4 wall alum tube upright
- ③ Handcrafted finial - mounted to upright cap assembly (see PART C: Construction Details, page 2.143).
- ④ Transpo Pole-Safe breakaway device with aluminum escutcheon cover (see PART C: Construction Details for different footer types). Verify all location conditions.

These drawings are meant for DESIGN INTENT ONLY and are not for construction. Contractor shall verify and be responsible for all dimensions and conditions of the job. Contractor shall be familiar with the site and conditions it presents. This office must be notified of any variations from the dimensions and conditions shown on this drawing. Shop drawings and details must be submitted to this office for approval prior to proceeding with fabrication. All copy shall be proofread by client and legal requirements checked by legal department.

VDIR.2
VEHICULAR DIRECTIONAL

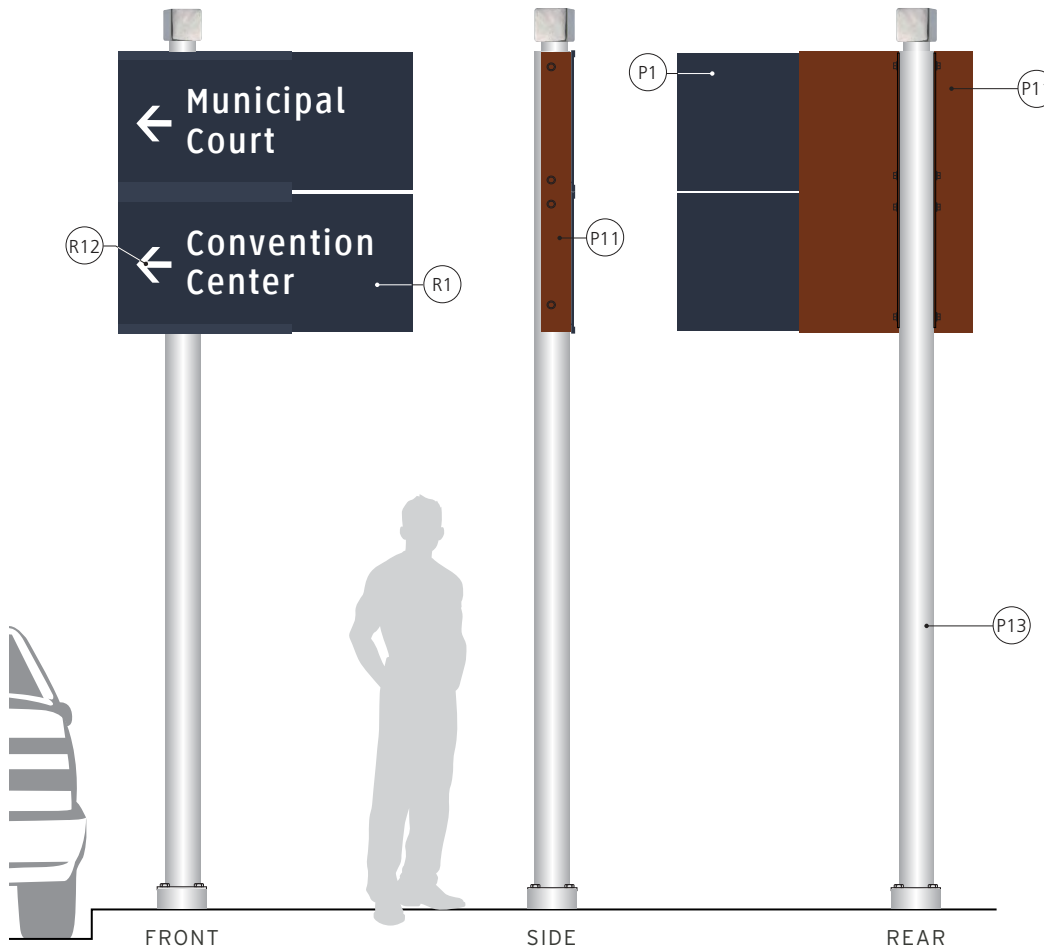

Vehicular directional signs are modular with panels that can be easily replaced. Signs can have 1-3 messages, and can hold either a graphic pictogram message or a text message.

Signs are typically used on roadways that have a speed limit of 25mph or less, per MUTCD section 2D.50 copy is 4" high, typeface is Clearview and both background and copy are retro-reflective. Sign posts are break-away.

1 **Color Schedule VDIR.2**
scale: 3/8"=1'-0"

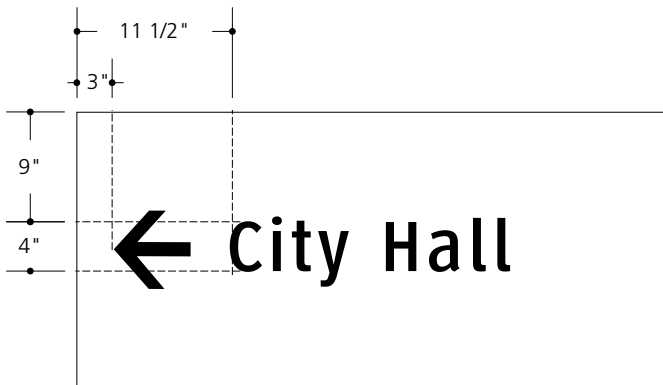

2 **Typical Layout Guidelines - 4"**
scale: 3/4"=1'-0"

These drawings are meant for DESIGN INTENT ONLY and are not for construction. Contractor shall verify and be responsible for all dimensions and conditions of the job. Contractor shall be familiar with the site and conditions it presents. This office must be notified of any variations from the dimensions and conditions shown on this drawing. Shop drawings and details must be submitted to the City of Austin for approval prior to proceeding with fabrication. All copy shall be proofread by the City of Austin and legal requirements checked by legal department.

VDIR.2
VEHICULAR DIRECTIONAL

All exposed surfaces shall have a anti-graffiti protectant. Painted surfaces will have a clear coating and vinyl surfaces shall have a clear vinyl over-lam as required by the paint and vinyl manufacturer.

All exposed fasteners shall be painted to match adjacent surface.

All sign structures shall be signed and sealed by a certified Texas structural engineer prior to fabrication.

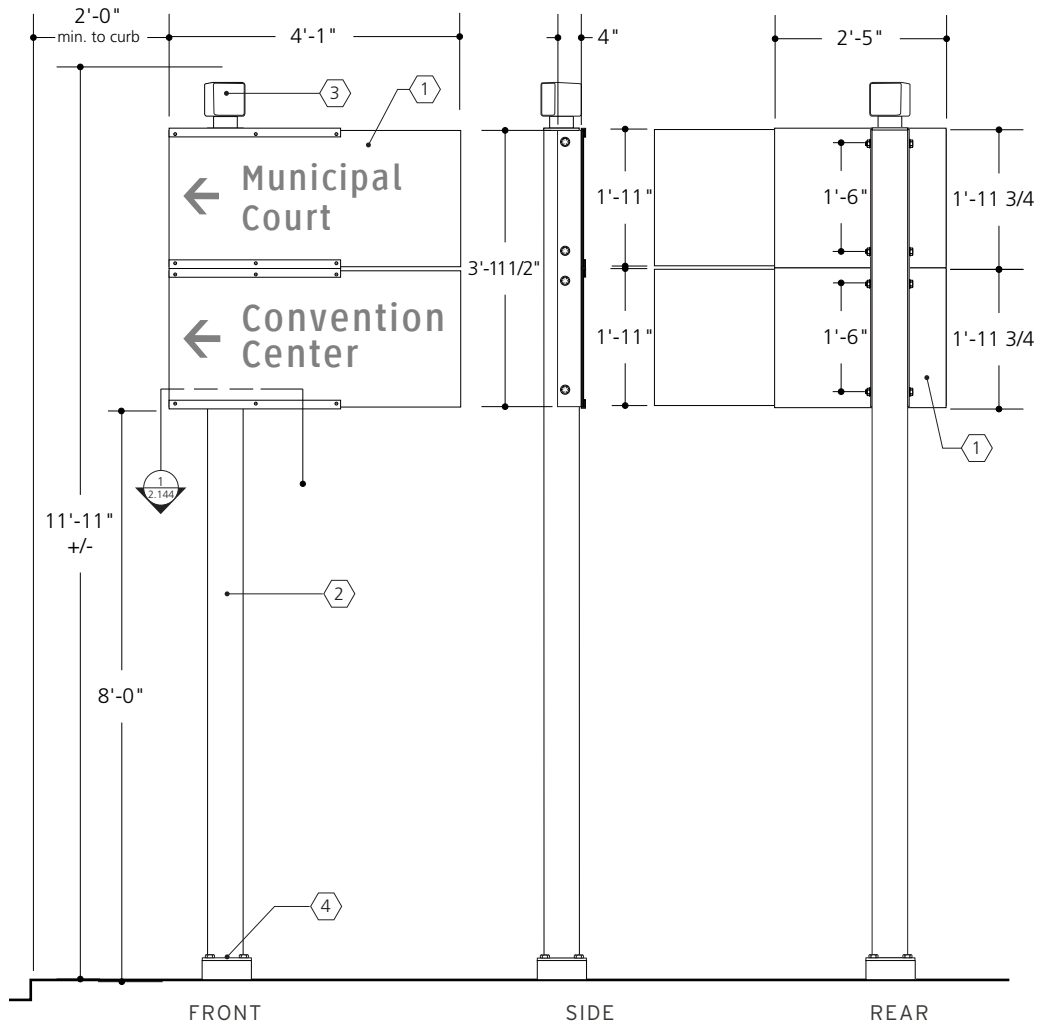

1 Elevations VDIR.2
scale: 3/8"=1'-0"

- ① Modular sign panel assembly (see PART C: Construction Details for more detail)
- ② 6" x 1/4 wall alum tube upright
- ③ Handcrafted finial - mounted to upright cap assembly (see PART C: Construction Details, page 2.143).
- ④ Transpo Pole-Safe breakaway device with aluminum escutcheon cover (see PART C: Construction Details for different footer types). Verify all location conditions.

These drawings are meant for DESIGN INTENT ONLY and are not for construction. Contractor shall verify and be responsible for all dimensions and conditions of the job. Contractor shall be familiar with the site and conditions it presents. This office must be notified of any variations from the dimensions and conditions shown on this drawing. Shop drawings and details must be submitted to this office for approval prior to proceeding with fabrication. All copy shall be proofread by client and legal requirements checked by legal department.

VDIR.2_LEFT
VEHICULAR DIRECTIONAL

Vehicular directional signs are modular with panels that can be easily replaced. Signs can have 1-3 messages, and can hold either a graphic pictogram message or a text message.

Signs are typically used on roadways that have a speed limit of 25mph or less, per MUTCD section 2D.50 copy is 4" high, typeface is Clearview and both background and copy are retro-reflective. Sign posts are break-away.

"Left-Mounted" versions are available for placement on opposite sides (left) of street.

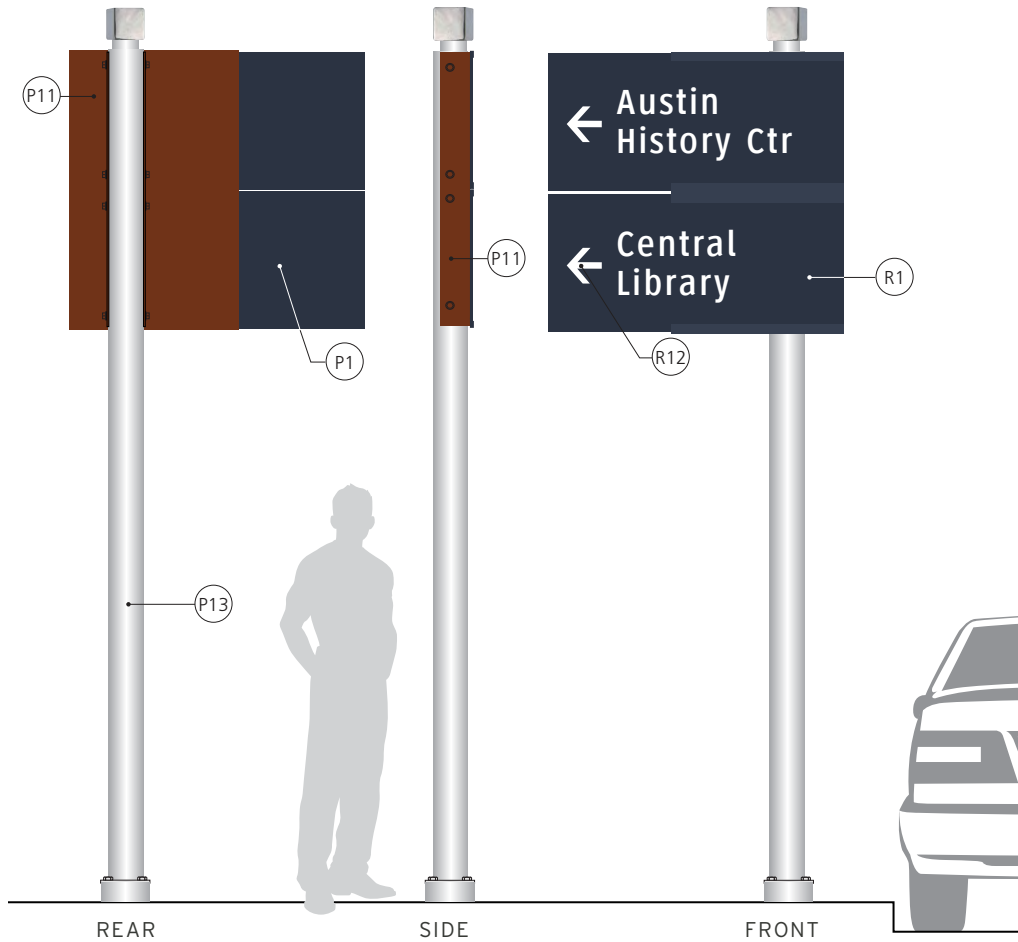

1 **Color Schedule VDIR.2_left**
scale: 3/8"=1'-0"

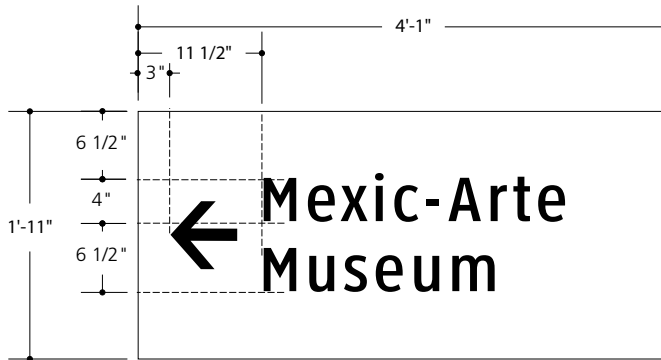

2 **Typical Layout Guidelines - 4"**
scale: 3/4"=1'-0"

These drawings are meant for DESIGN INTENT ONLY and are not for construction. Contractor shall verify and be responsible for all dimensions and conditions of the job. Contractor shall be familiar with the site and conditions it presents. This office must be notified of any variations from the dimensions and conditions shown on this drawing. Shop drawings and details must be submitted to the City of Austin for approval prior to proceeding with fabrication. All copy shall be proofread by the City of Austin and legal requirements checked by legal department.

VDIR.2_LEFT
VEHICULAR DIRECTIONAL

All exposed surfaces shall have a anti-graffiti protectant. Painted surfaces will have a clear coating and vinyl surfaces shall have a clear vinyl over-lam as required by the paint and vinyl manufacturer.

All exposed fasteners shall be painted to match adjacent surface.

All sign structures shall be signed and sealed by a certified Texas structural engineer prior to fabrication.

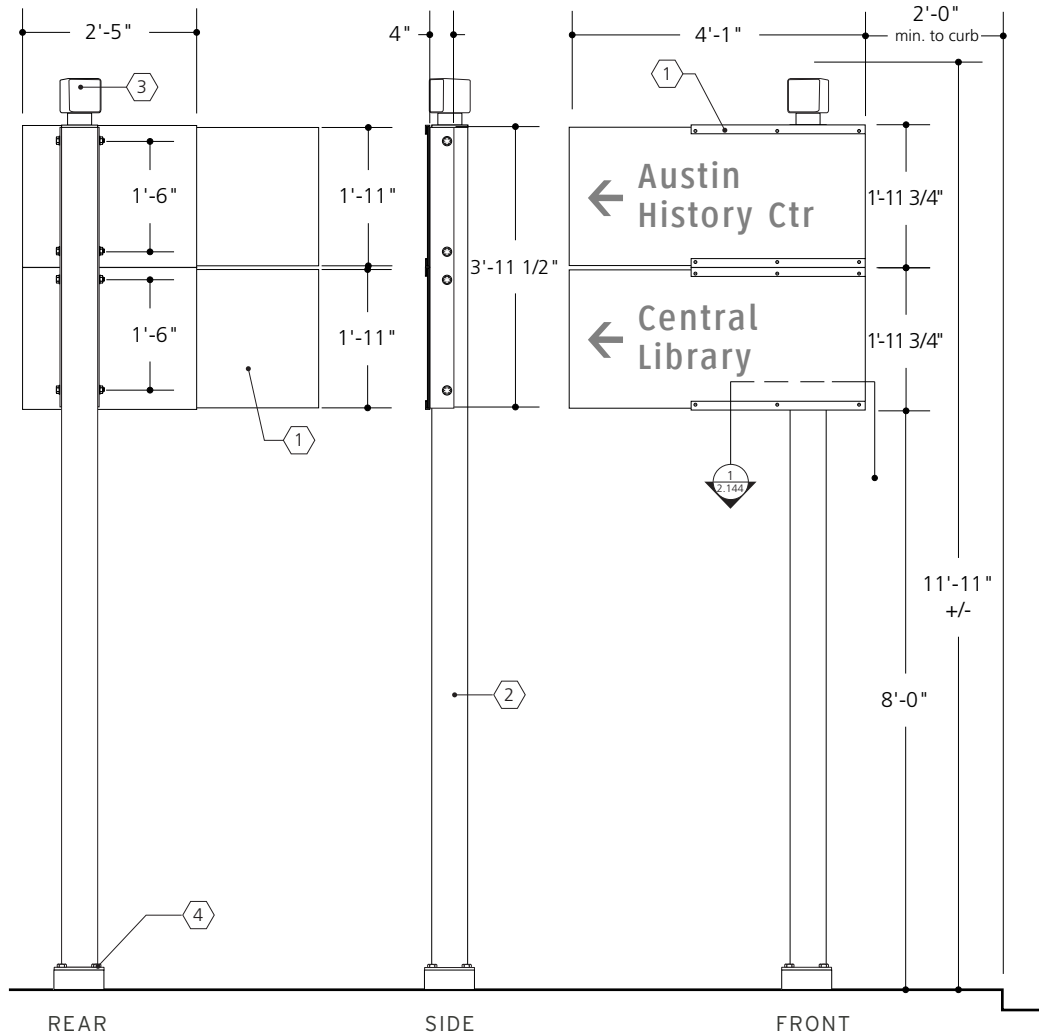

1 Elevations VDIR.2 left
scale: 3/8"=1'-0"

- 1 Modular sign panel assembly (see PART C: Construction Details for more detail)
- 2 6" x 1/4 wall alum tube upright
- 3 Handcrafted finial - mounted to upright cap assembly (see PART C: Construction Details, page 2.143).
- 4 Transpo Pole-Safe breakaway device with aluminum escutcheon cover (see PART C: Construction Details for different footer types). Verify all location conditions.

These drawings are meant for DESIGN INTENT ONLY and are not for construction. Contractor shall verify and be responsible for all dimensions and conditions of the job. Contractor shall be familiar with the site and conditions it presents. This office must be notified of any variations from the dimensions and conditions shown on this drawing. Shop drawings and details must be submitted to this office for approval prior to proceeding with fabrication. All copy shall be proofread by client and legal requirements checked by legal department.

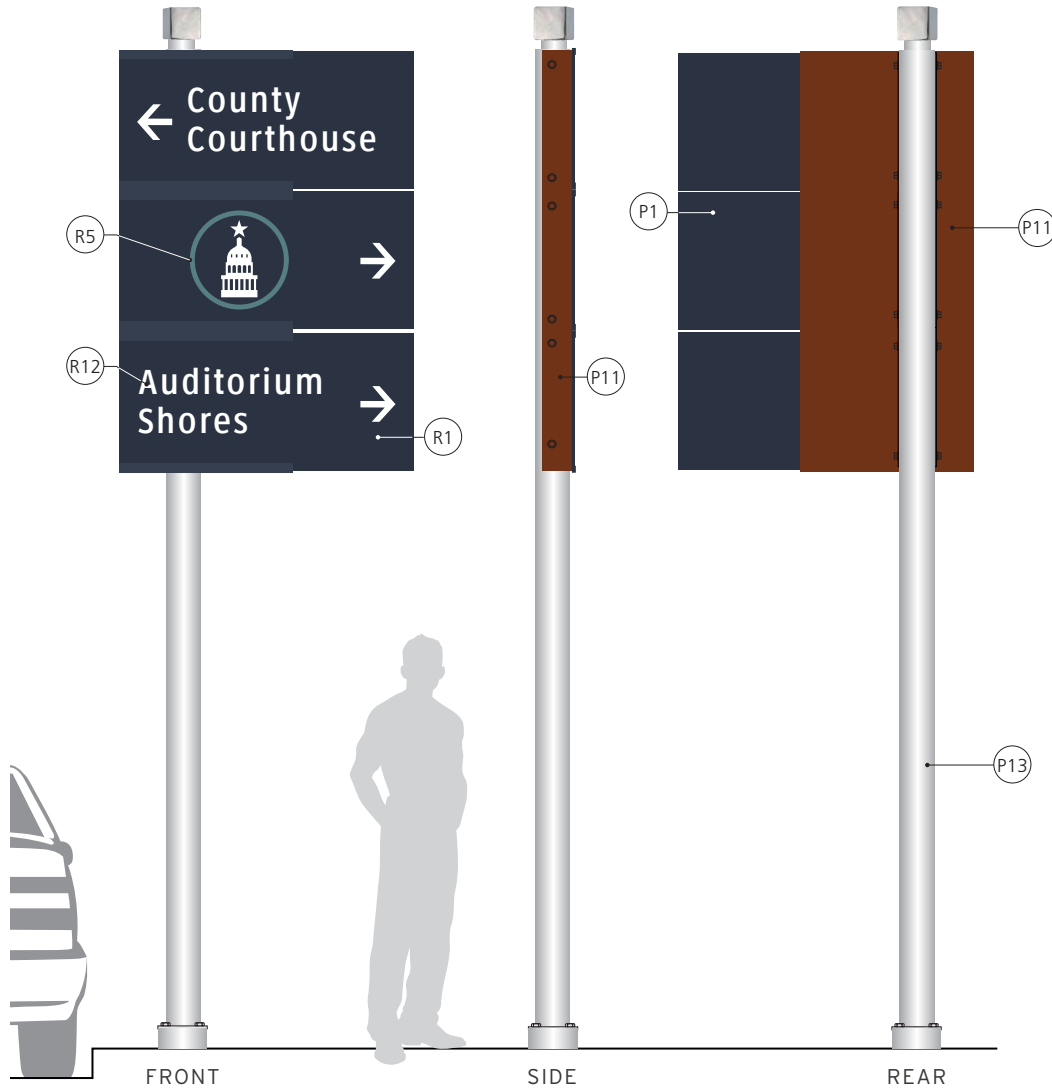

VDIR.3
VEHICULAR DIRECTIONAL

Vehicular directional signs are modular with panels that can be easily replaced. Signs can have 1-3 messages, and can hold either a graphic pictogram message or a text message.

Signs are typically used on roadways that have a speed limit of 25mph or less, per MUTCD section 2D.50 copy is 4" high, typeface is Clearview and both background and copy are retro-reflective. Sign posts are break-away.

1 **Color Schedule VDIR.3**
scale: 3/8"=1'-0"

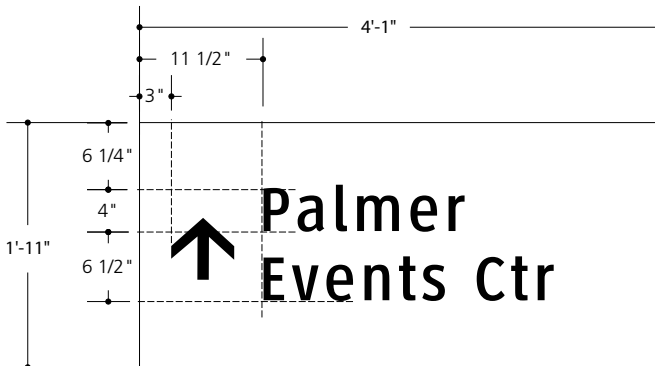

2 **Typical Layout Guidelines - 4"**
scale: 3/4"=1'-0"

These drawings are meant for DESIGN INTENT ONLY and are not for construction. Contractor shall verify and be responsible for all dimensions and conditions of the job. Contractor shall be familiar with the site and conditions it presents. This office must be notified of any variations from the dimensions and conditions shown on this drawing. Shop drawings and details must be submitted to the City of Austin for approval prior to proceeding with fabrication. All copy shall be proofread by the City of Austin and legal requirements checked by legal department.

VDIR.3
VEHICULAR DIRECTIONAL

All exposed surfaces shall have an anti-graffiti protectant. Painted surfaces will have a clear coating and vinyl surfaces shall have a clear vinyl over-lam as required by the paint and vinyl manufacturer.

All exposed fasteners shall be painted to match adjacent surface.

All sign structures shall be signed and sealed by a certified Texas structural engineer prior to fabrication.

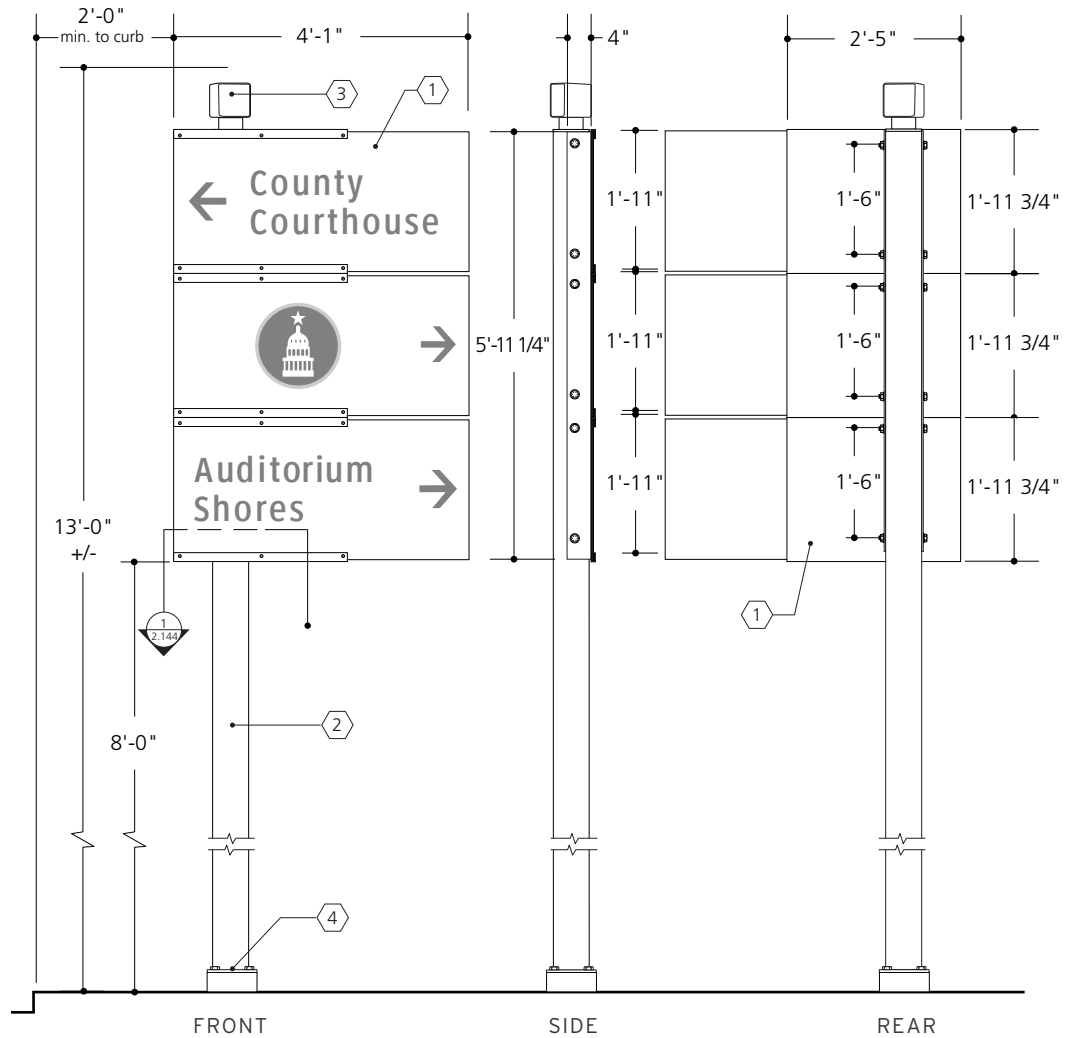

1 Elevations VDIR.3
scale: 3/8"=1'-0"

- 1 Modular sign panel assembly (see PART C: Construction Details for more detail)
- 2 6" x 1/4 wall alum tube upright
- 3 Handcrafted finial - mounted to upright cap assembly (see PART C: Construction Details, page 2.143).
- 4 Transpo Pole-Safe breakaway device with aluminum escutcheon cover (see PART C: Construction Details for different footer types). Verify all location conditions.

These drawings are meant for DESIGN INTENT ONLY and are not for construction. Contractor shall verify and be responsible for all dimensions and conditions of the job. Contractor shall be familiar with the site and conditions it presents. This office must be notified of any variations from the dimensions and conditions shown on this drawing. Shop drawings and details must be submitted to this office for approval prior to proceeding with fabrication. All copy shall be proofread by client and legal requirements checked by legal department.

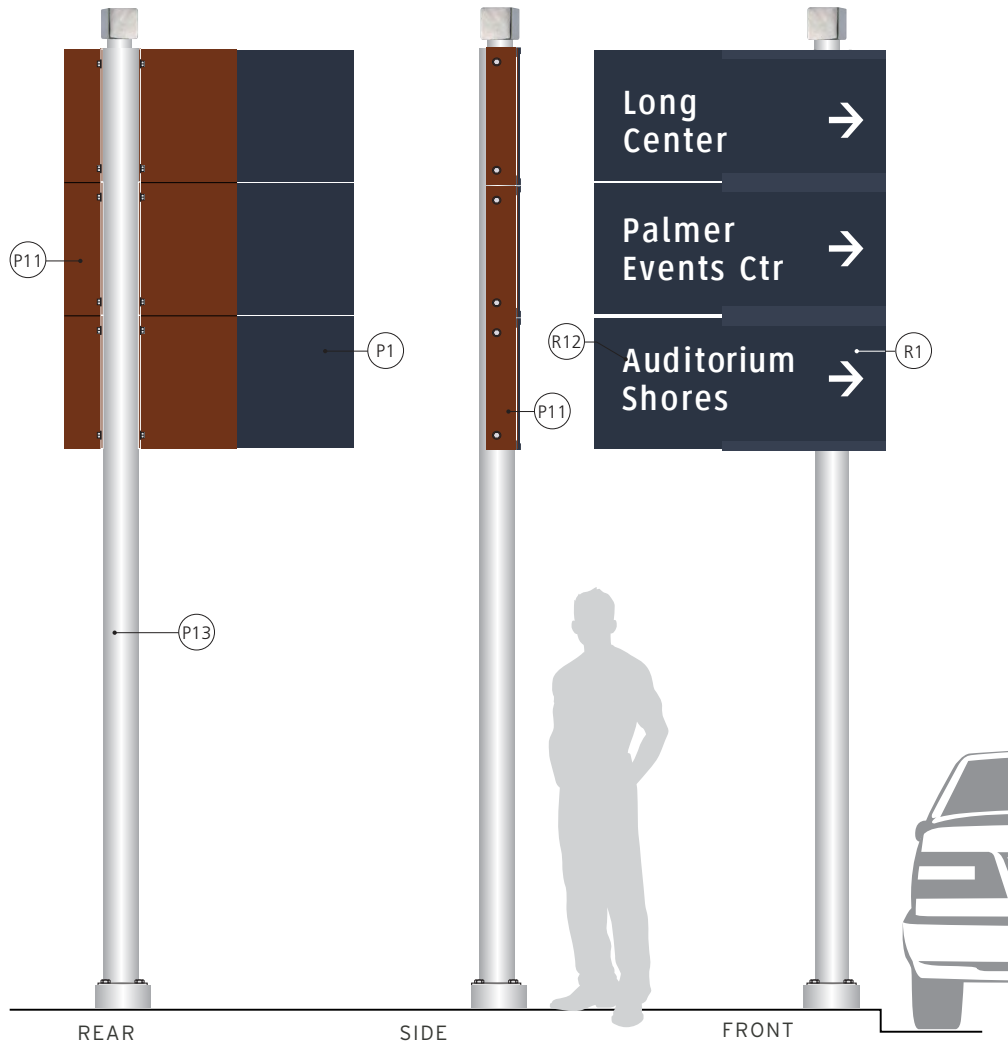

VDIR.3_LEFT
VEHICULAR DIRECTIONAL

Vehicular directional signs are modular with panels that can be easily replaced. Signs can have 1-3 messages, and can hold either a graphic pictogram message or a text message.

Signs are typically used on roadways that have a speed limit of 25mph or less, per MUTCD section 2D.50 copy is 4" high, typeface is Clearview and both background and copy are retro-reflective. Sign posts are break-away.

"Left-Mounted" versions are available for placement on opposite sides (left) of street.

1 **Color Schedule VDIR.3_left**
scale: 3/8"=1'-0"

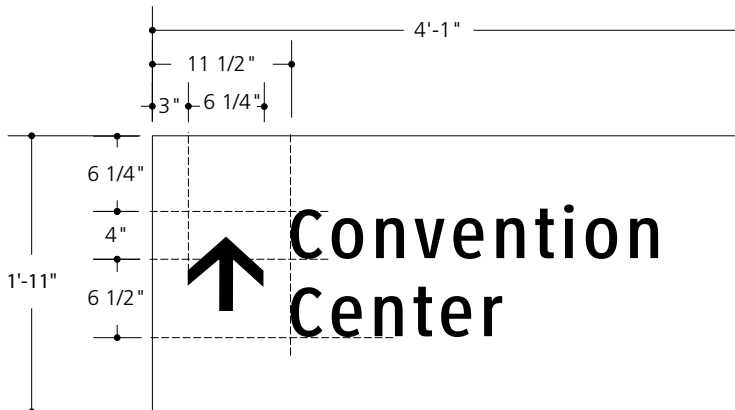

2 **Typical Layout Guidelines - 4"**
scale: 3/4"=1'-0"

These drawings are meant for DESIGN INTENT ONLY and are not for construction. Contractor shall verify and be responsible for all dimensions and conditions of the job. Contractor shall be familiar with the site and conditions it presents. This office must be notified of any variations from the dimensions and conditions shown on this drawing. Shop drawings and details must be submitted to the City of Austin for approval prior to proceeding with fabrication. All copy shall be proofread by the City of Austin and legal requirements checked by legal department.

VDIR.3_LEFT
VEHICULAR DIRECTIONAL

All exposed surfaces shall have a anti-graffiti protectant. Painted surfaces will have a clear coating and vinyl surfaces shall have a clear vinyl over-lam as required by the paint and vinyl manufacturer.

All exposed fasteners shall be painted to match adjacent surface.

All sign structures shall be signed and sealed by a certified Texas structural engineer prior to fabrication.

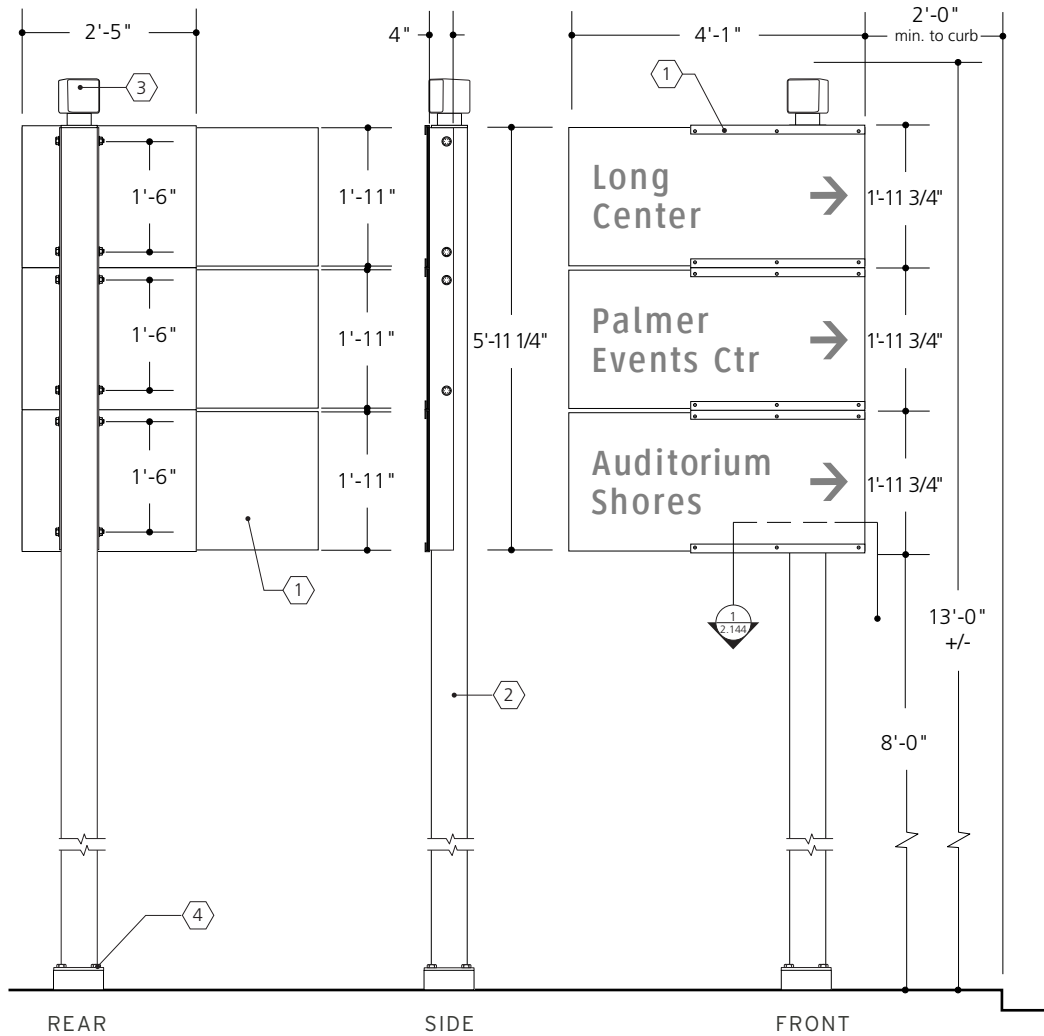

1 Elevations VDIR.3 left
scale: 3/8"=1'-0"

- 1 Modular sign panel assembly (see PART C: Construction Details for more detail)
- 2 6" x 1/4 wall alum tube upright
- 3 Handcrafted finial - mounted to upright cap assembly (see PART C: Construction Details, page 2.143).
- 4 Transpo Pole-Safe breakaway device with aluminum escutcheon cover (see PART C: Construction Details for different footer types). Verify all location conditions.

These drawings are meant for DESIGN INTENT ONLY and are not for construction. Contractor shall verify and be responsible for all dimensions and conditions of the job. Contractor shall be familiar with the site and conditions it presents. This office must be notified of any variations from the dimensions and conditions shown on this drawing. Shop drawings and details must be submitted to this office for approval prior to proceeding with fabrication. All copy shall be proofread by client and legal requirements checked by legal department.

VDIR.4
TXDOT VEHICULAR
DIRECTIONAL

TXDOT compliant vehicular directional signs are modular with panels that can be easily replaced. Signs can have 1-3 messages, and can hold either a text message, or text message with a graphic pictogram.

Signs are typically used on roadways that have a speed limit of 30mph or more, per MUTCD section 2D.50 copy is 6" high, typeface is Clearview and both background and copy are retro-reflective. Sign posts are break-away.

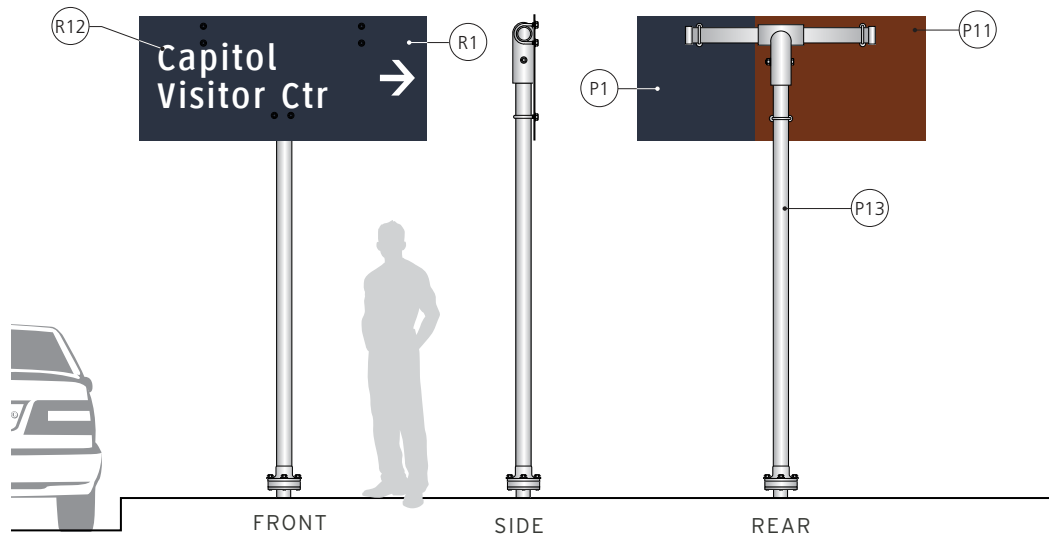

1 **Color Schedule VDIR.4**
 scale: 1/4"=1'-0"

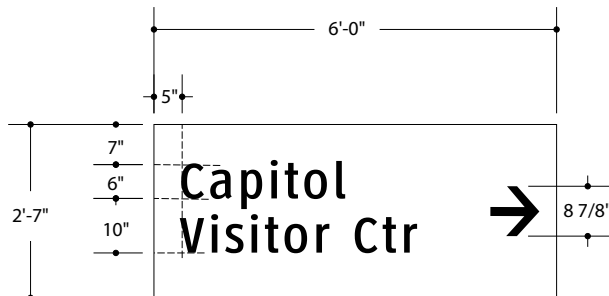

2 **Typical Layout Guidelines - 6"**
 scale: 3/8"=1'-0"

These drawings are meant for DESIGN INTENT ONLY and are not for construction. Contractor shall verify and be responsible for all dimensions and conditions of the job. Contractor shall be familiar with the site and conditions it presents. This office must be notified of any variations from the dimensions and conditions shown on this drawing. Shop drawings and details must be submitted to the City of Austin for approval prior to proceeding with fabrication. All copy shall be proofread by the City of Austin and legal requirements checked by legal department.

VDIR.4
TXDOT VEHICULAR
DIRECTIONAL

All exposed surfaces shall have an anti-graffiti protectant. Painted surfaces will have a clear coating and vinyl surfaces shall have a clear vinyl over-lam as required by the paint and vinyl manufacturer.

All exposed fasteners shall be painted to match adjacent surface.

All sign structures shall be signed and sealed by a certified Texas structural engineer prior to fabrication.

All construction details, materials and mounting for this sign type shall meet TXDOT Standards.

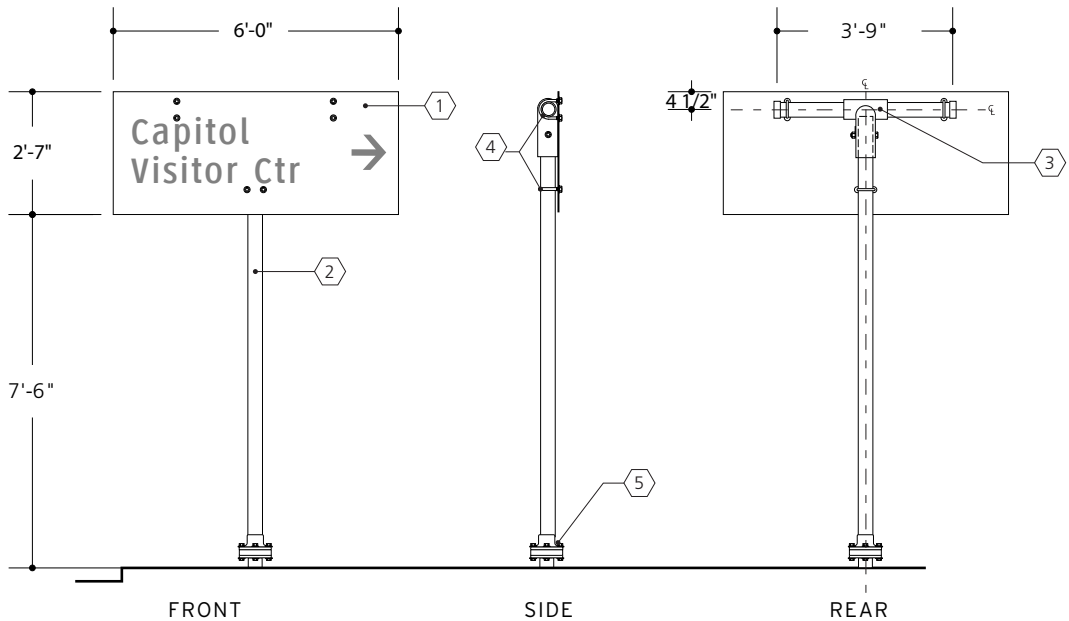

1 Elevations VDIR.4
 scale: 1/4"=1'-0"

- ① 1/4" alum message panel with 1/4" alum strips chemically welded to face
- ② Schedule 80 - 3 1/2" OD galvanized steel pipe upright (see PART C: Construction Details for additional details).
- ③ Galvanized steel pipe T-bracket fastened to upright pipe with 1/2" x 4" galvanized hex through-bolt.
- ④ Galvanized steel U-bolt with hex nuts.
- ⑤ Galvanized steel slip-plate breakaway connectors.

NOTE: Fabrication of sign type must comply with TXDOT standard plan highway sign specification details (see PART C: Construction Details for more detailed TXDOT specifications).

These drawings are meant for DESIGN INTENT ONLY and are not for construction. Contractor shall verify and be responsible for all dimensions and conditions of the job. Contractor shall be familiar with the site and conditions it presents. This office must be notified of any variations from the dimensions and conditions shown on this drawing. Shop drawings and details must be submitted to this office for approval prior to proceeding with fabrication. All copy shall be proofread by client and legal requirements checked by legal department.

VDIR.5
TXDOT VEHICULAR
DIRECTIONAL

TXDOT compliant vehicular directional signs are modular with panels that can be easily replaced. Signs can have 1-3 messages, and can hold either a text message, or text message with a graphic pictogram.

Signs are typically used on roadways that have a speed limit of 30mph or more, per MUTCD section 2D.50 copy is 6" high, typeface is Clearview and both background and copy are retro-reflective. Sign posts are break-away.

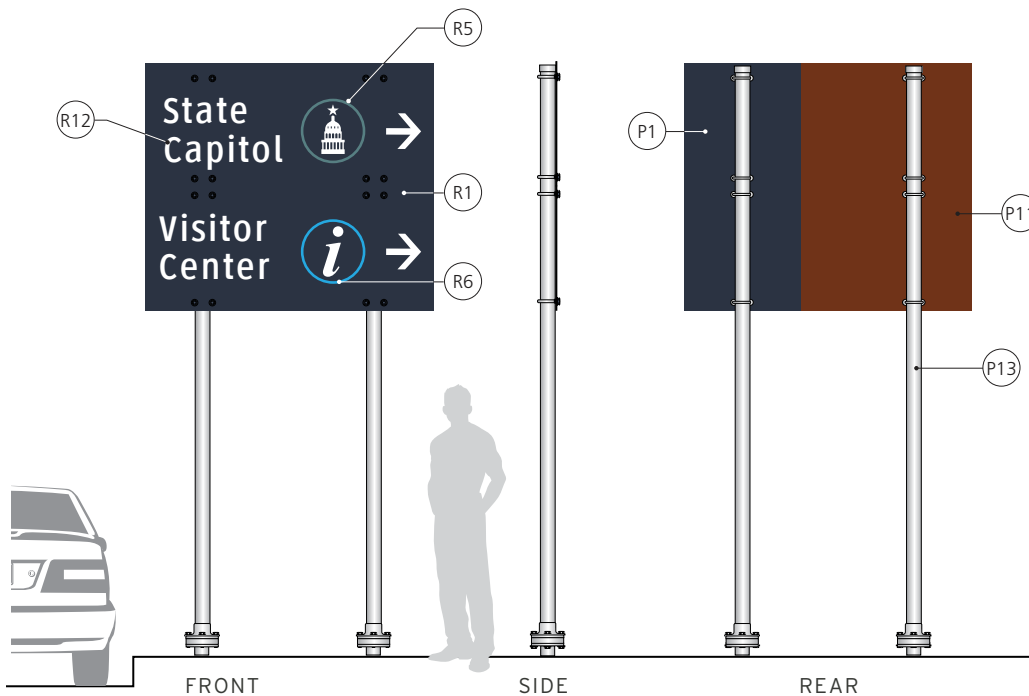

1 Color Schedule VDIR.5
 scale: 1/4"=1'-0"

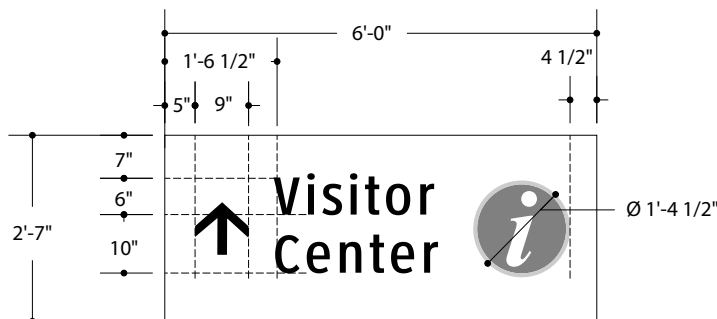

2 Typical Layout Guidelines - 6"
 scale: 3/8"=1'-0"

These drawings are meant for DESIGN INTENT ONLY and are not for construction. Contractor shall verify and be responsible for all dimensions and conditions of the job. Contractor shall be familiar with the site and conditions it presents. This office must be notified of any variations from the dimensions and conditions shown on this drawing. Shop drawings and details must be submitted to the City of Austin for approval prior to proceeding with fabrication. All copy shall be proofread by the City of Austin and legal requirements checked by legal department.

VDIR.5
TXDOT VEHICULAR
DIRECTIONAL

All exposed surfaces shall have an anti-graffiti protectant. Painted surfaces will have a clear coating and vinyl surfaces shall have a clear vinyl over-lam as required by the paint and vinyl manufacturer.

All exposed fasteners shall be painted to match adjacent surface.

All sign structures shall be signed and sealed by a certified Texas structural engineer prior to fabrication.

All construction details, materials and mounting for this sign type shall meet TXDOT Standards.

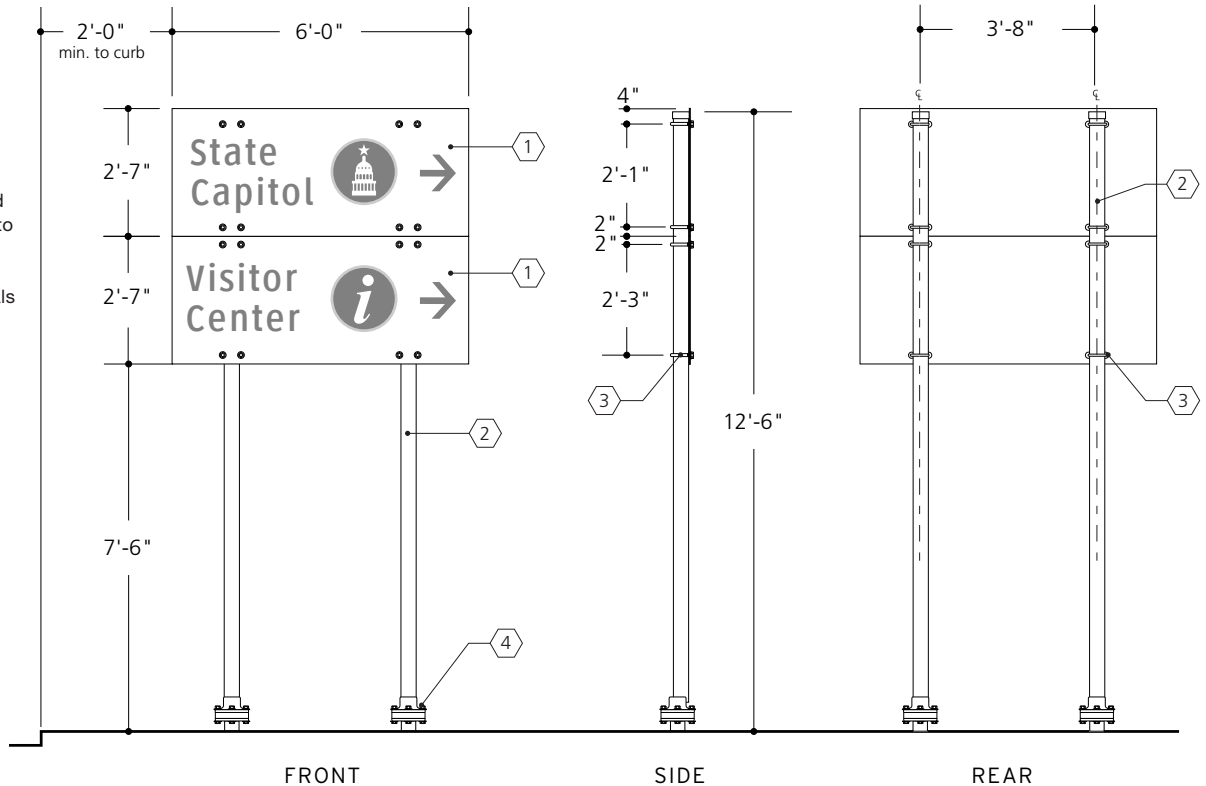

1 Elevations VDIR.5
 scale: 1/4"=1'-0"

- ① 1/4" aluminum sheet message panel
- ② Schedule 80 - 3 1/2" OD galvanized steel pipe upright (see PART C: Construction Details for additional details).
- ③ Galvanized steel U-bolt with hex nuts.
- ④ Galvanized steel slip-plate breakaway connectors.

NOTE: Fabrication of sign type must comply with TXDOT standard plan highway sign specification details (see PART C: Construction Details for more detailed TXDOT specifications).

These drawings are meant for DESIGN INTENT ONLY and are not for construction. Contractor shall verify and be responsible for all dimensions and conditions of the job. Contractor shall be familiar with the site and conditions it presents. This office must be notified of any variations from the dimensions and conditions shown on this drawing. Shop drawings and details must be submitted to this office for approval prior to proceeding with fabrication. All copy shall be proofread by client and legal requirements checked by legal department.

VDIR.6
TXDOT VEHICULAR
DIRECTIONAL

TXDOT compliant vehicular directional signs are modular with panels that can be easily replaced. Signs can have 1-3 messages, and can hold either a text message, or text message with a graphic pictogram.

Signs are typically used on roadways that have a speed limit of 30mph or more, per MUTCD section 2D.50 copy is 6" high, typeface is Clearview and both background and copy are retro-reflective. Sign posts are break-away.

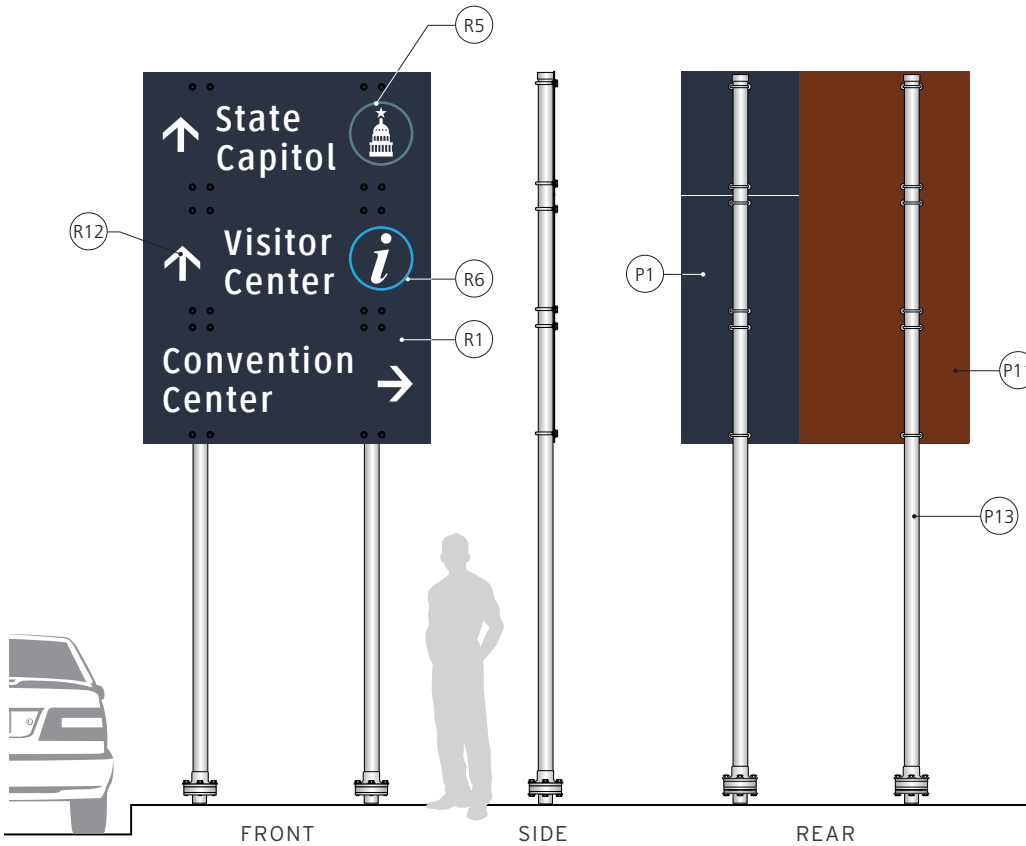

1 **Color Schedule VDIR.6**
 scale: 1/4"=1'-0"

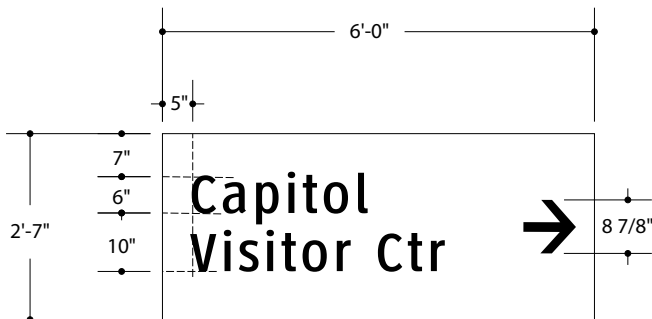

2 **Typical Layout Guidelines - 6"**
 scale: 3/8"=1'-0"

These drawings are meant for DESIGN INTENT ONLY and are not for construction. Contractor shall verify and be responsible for all dimensions and conditions of the job. Contractor shall be familiar with the site and conditions it presents. This office must be notified of any variations from the dimensions and conditions shown on this drawing. Shop drawings and details must be submitted to the City of Austin for approval prior to proceeding with fabrication. All copy shall be proofread by the City of Austin and legal requirements checked by legal department.

VDIR.6
TXDOT VEHICULAR
DIRECTIONAL

All exposed surfaces shall have a anti-graffiti protectant. Painted surfaces will have a clear coating and vinyl surfaces shall have a clear vinyl over-lam as required by the paint and vinyl manufacturer.

All exposed fasteners shall be painted to match adjacent surface.

All sign structures shall be signed and sealed by a certified Texas structural engineer prior to fabrication.

All construction details, materials and mounting for this sign type shall meet TXDOT Standards.

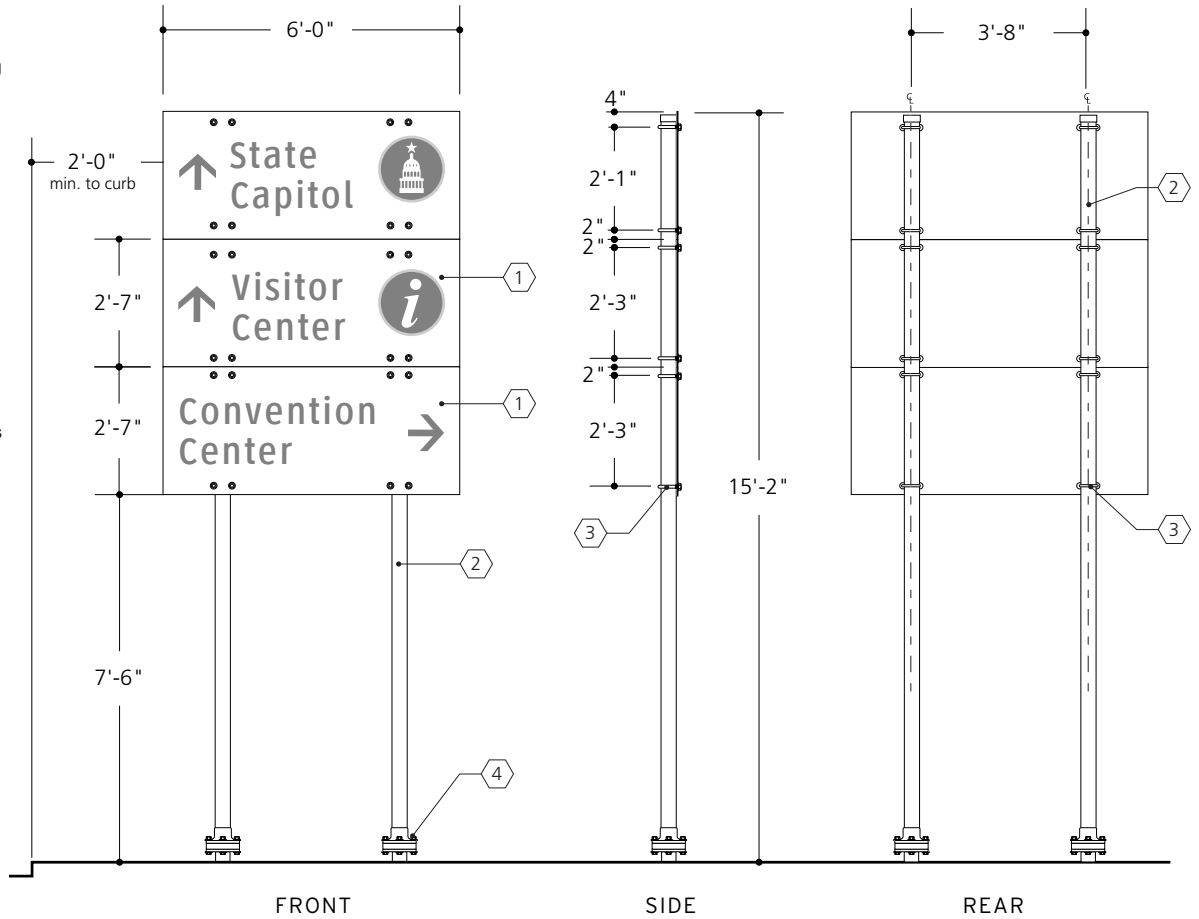

1 Elevations VDIR.6
 scale: 1/4"=1'-0"

- 1 1/4" aluminum sheet message panel
- 2 Schedule 80 - 3 1/2" OD galvanized steel pipe upright (see PART C: Construction Details for additional details).
- 3 Galvanized steel U-bolt with hex nuts.
- 4 Galvanized steel slip-plate breakaway connectors.

NOTE: Fabrication of sign type must comply with TXDOT standard plan highway sign specification details (see PART C: Construction Details for more detailed TXDOT specifications).

These drawings are meant for DESIGN INTENT ONLY and are not for construction. Contractor shall verify and be responsible for all dimensions and conditions of the job. Contractor shall be familiar with the site and conditions it presents. This office must be notified of any variations from the dimensions and conditions shown on this drawing. Shop drawings and details must be submitted to this office for approval prior to proceeding with fabrication. All copy shall be proofread by client and legal requirements checked by legal department.

**PARK.1
PARKING DIRECTIONAL**

Parking directional signs are modular with panels that can be easily replaced. Signs can have 1-3 messages, and can hold either a graphic pictogram message or a text message.

Parking Directional signs can direct to a lot by name or include the destination the lot serves.

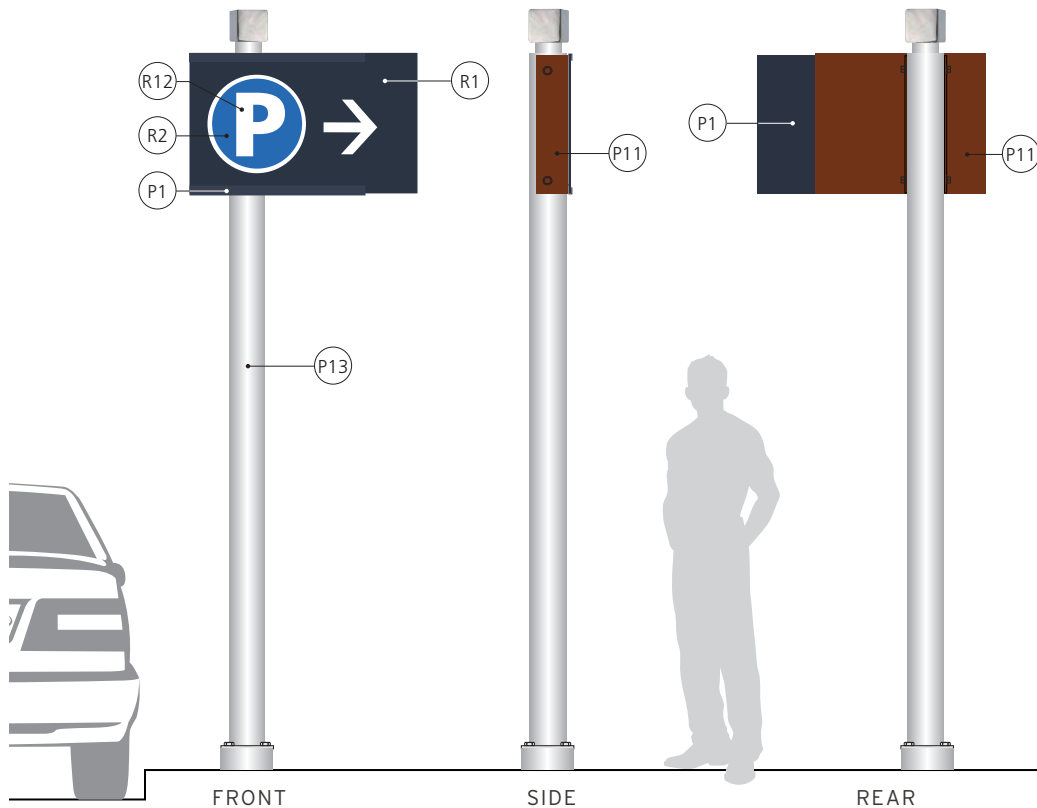

1 Color Schedule PARK.1
scale: 3/8"=1'-0"

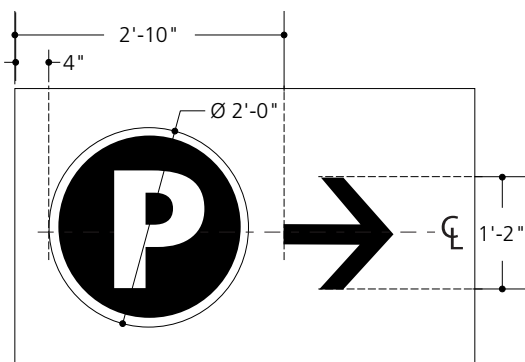

2 Typical Layout Guidelines
scale: 1/2"=1'-0"

These drawings are meant for DESIGN INTENT ONLY and are not for construction. Contractor shall verify and be responsible for all dimensions and conditions of the job. Contractor shall be familiar with the site and conditions it presents. This office must be notified of any variations from the dimensions and conditions shown on this drawing. Shop drawings and details must be submitted to the City of Austin for approval prior to proceeding with fabrication. All copy shall be proofread by the City of Austin and legal requirements checked by legal department.

PARK.1
PARKING DIRECTIONAL

All exposed surfaces shall have a anti-graffiti protectant. Painted surfaces will have a clear coating and vinyl surfaces shall have a clear vinyl over-lam as required by the paint and vinyl manufacturer.

All exposed fasteners shall be painted to match adjacent surface.

All sign structures shall be signed and sealed by a certified Texas structural engineer prior to fabrication.

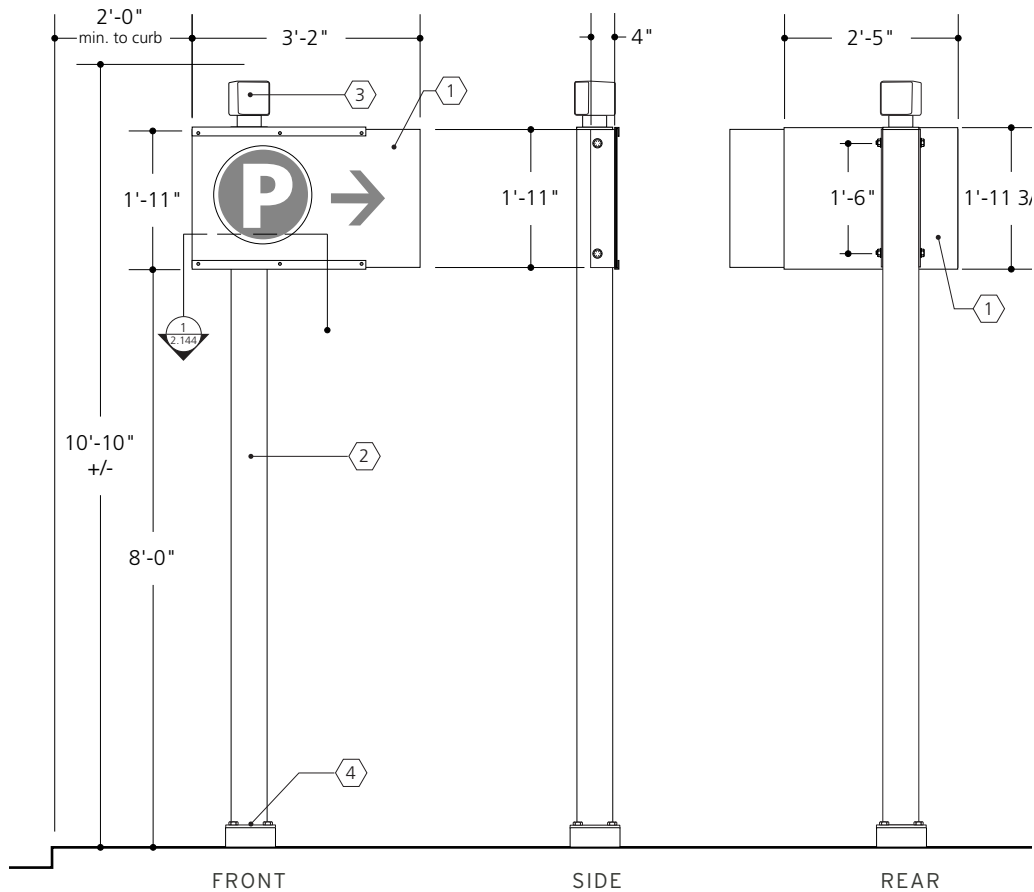

1 Elevations PARK.1
scale: 3/8"=1'-0"

- 1 Modular sign panel assembly (see PART C: Construction Details for more detail).
- 2 6" x 1/4 wall alum tube upright
- 3 Handcrafted finial - mounted to upright cap assembly (see PART C: Construction Details, page 2.143).
- 4 Transpo Pole-Safe breakaway device with aluminum escutcheon cover (see PART C: Construction Details for different footer types). Verify all location conditions.

These drawings are meant for DESIGN INTENT ONLY and are not for construction. Contractor shall verify and be responsible for all dimensions and conditions of the job. Contractor shall be familiar with the site and conditions it presents. This office must be notified of any variations from the dimensions and conditions shown on this drawing. Shop drawings and details must be submitted to this office for approval prior to proceeding with fabrication. All copy shall be proofread by client and legal requirements checked by legal department.

PARK.1_LEFT
PARKING DIRECTIONAL

Parking directional signs are modular with panels that can be easily replaced. Signs can have 1-3 messages, and can hold either a graphic pictogram message or a text message.

Parking Directional signs can direct to a lot by name or include the destination the lot serves.

"Left-Mounted" versions are available for placement on opposite sides (left) of street.

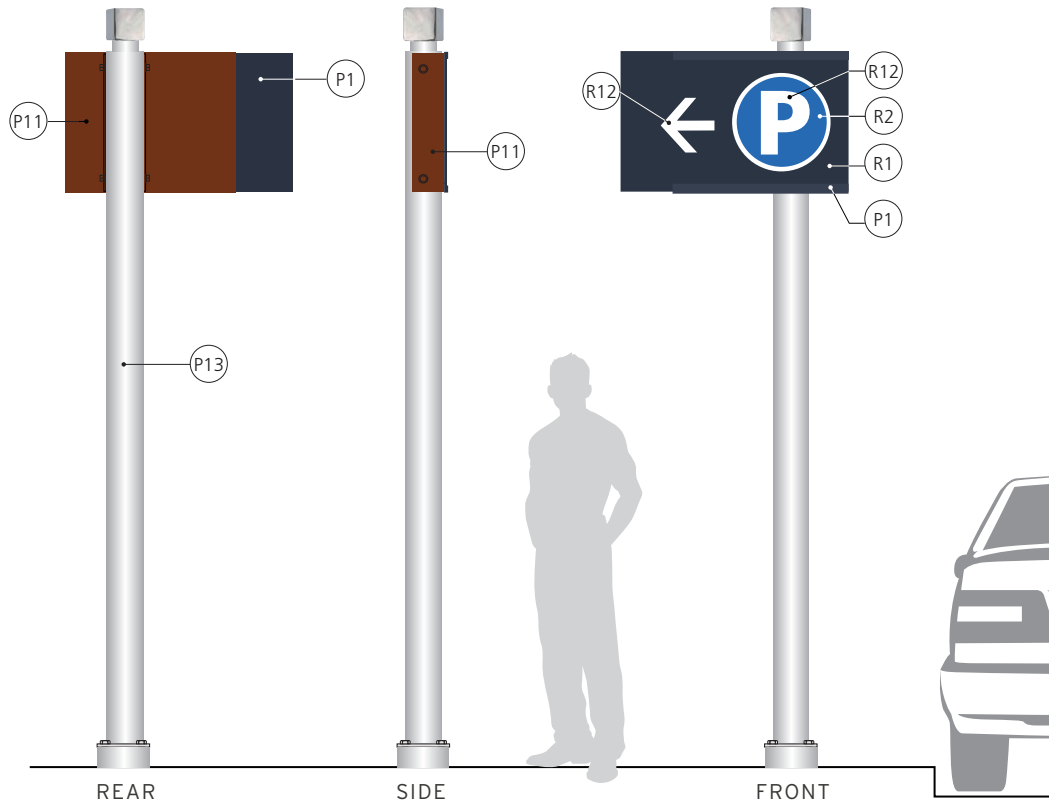

1 **Color Schedule PARK.1_left**
scale: 3/8"=1'-0"

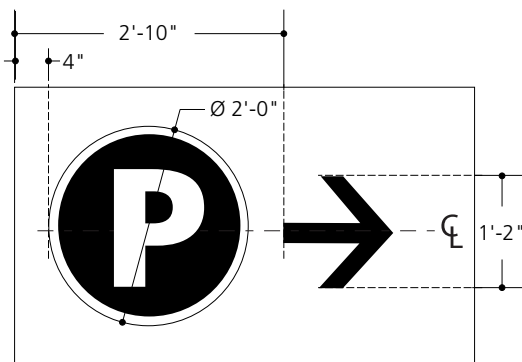

2 **Typical Layout Guidelines**
scale: 1/2"=1'-0"

These drawings are meant for DESIGN INTENT ONLY and are not for construction. Contractor shall verify and be responsible for all dimensions and conditions of the job. Contractor shall be familiar with the site and conditions it presents. This office must be notified of any variations from the dimensions and conditions shown on this drawing. Shop drawings and details must be submitted to the City of Austin for approval prior to proceeding with fabrication. All copy shall be proofread by the City of Austin and legal requirements checked by legal department.

PARK.1_LEFT
PARKING DIRECTIONAL

All exposed surfaces shall have a anti-graffiti protectant. Painted surfaces will have a clear coating and vinyl surfaces shall have a clear vinyl over-lam as required by the paint and vinyl manufacturer.

All exposed fasteners shall be painted to match adjacent surface.

All sign structures shall be signed and sealed by a certified Texas structural engineer prior to fabrication.

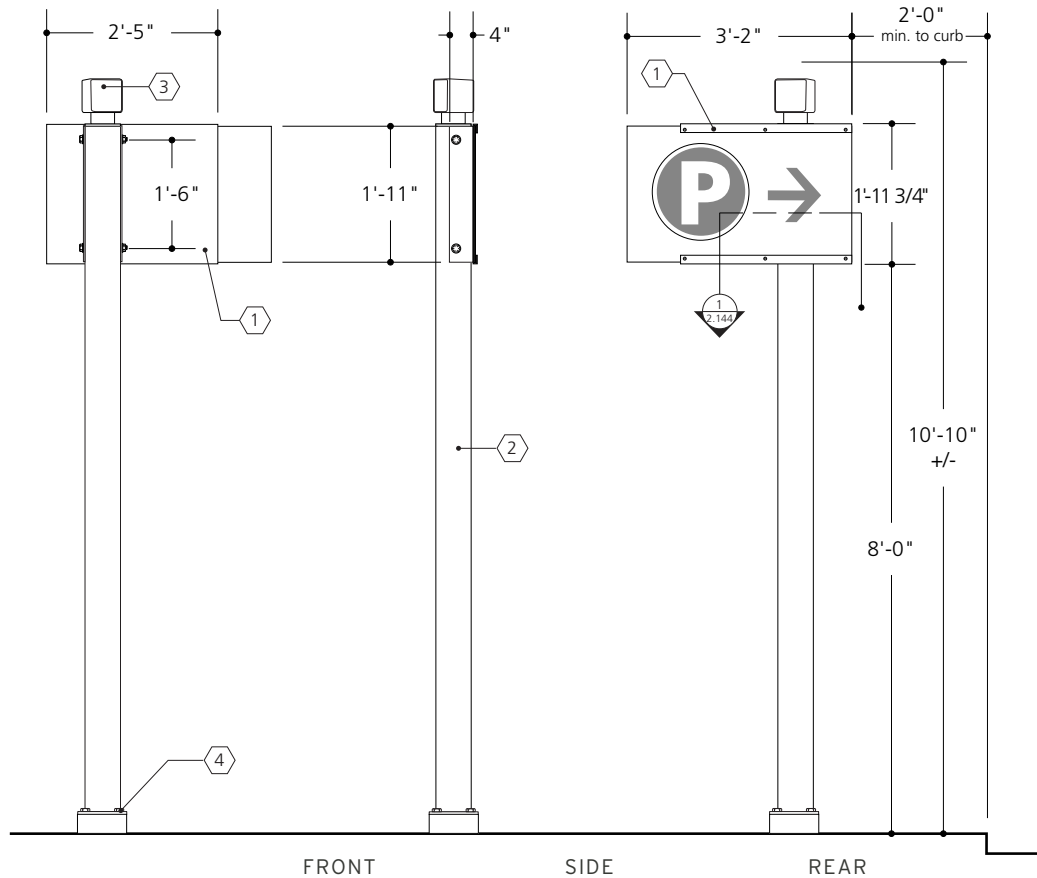

① Elevations PARK.1 left
scale: 3/8"=1'-0"

- ① Modular sign panel assembly (see PART C: Construction Details for more detail)
- ② 6" x 1/4 wall alum tube upright
- ③ Handcrafted finial - mounted to upright cap assembly (see PART C: Construction Details, page 2.143).
- ④ Transpo Pole-Safe breakaway device with aluminum escutcheon cover (see PART C: Construction Details for different footer types). Verify all location conditions.

These drawings are meant for DESIGN INTENT ONLY and are not for construction. Contractor shall verify and be responsible for all dimensions and conditions of the job. Contractor shall be familiar with the site and conditions it presents. This office must be notified of any variations from the dimensions and conditions shown on this drawing. Shop drawings and details must be submitted to this office for approval prior to proceeding with fabrication. All copy shall be proofread by client and legal requirements checked by legal department.

**PARK.2
PARKING DIRECTIONAL**

Parking directional signs are modular with panels that can be easily replaced. Signs can have 1-3 messages, and can hold either a graphic pictogram message or a text message.

Parking Directional signs can direct to a lot by name or include the destination the lot serves.

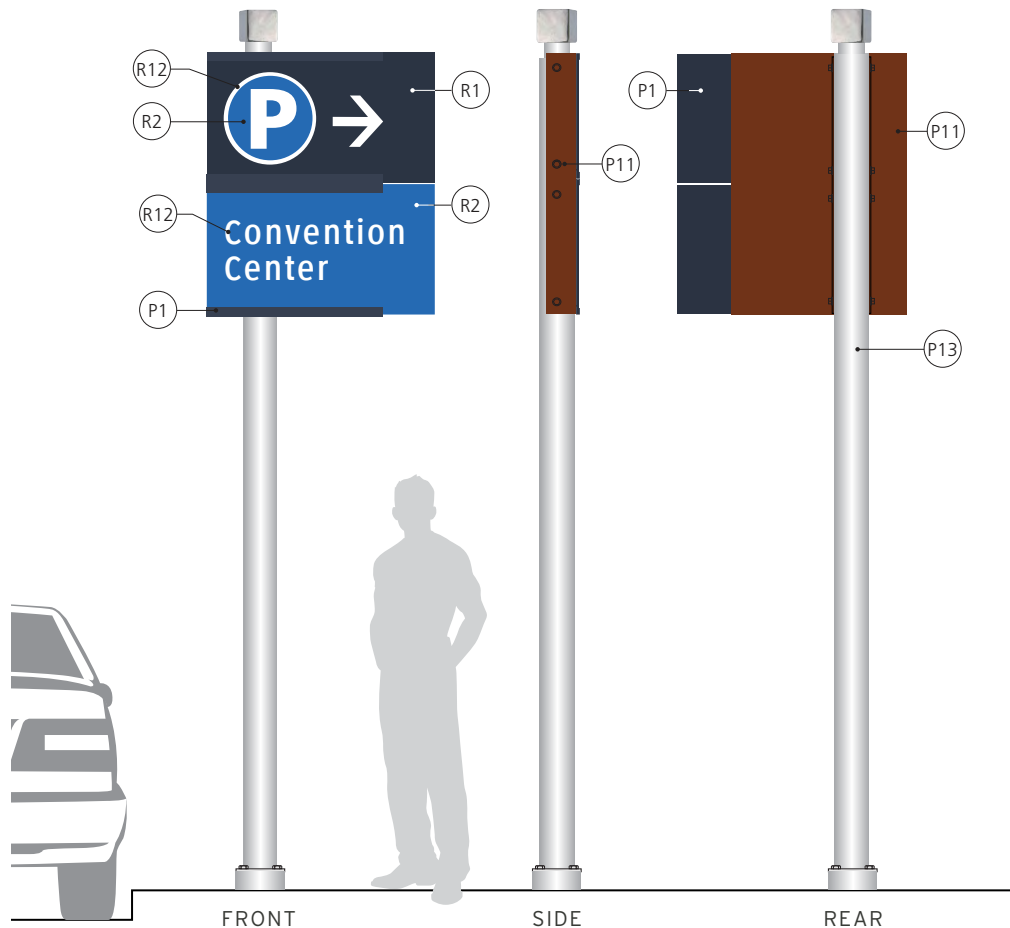

1 **Color Schedule PARK.2**
scale: 3/8"=1'-0"

These drawings are meant for DESIGN INTENT ONLY and are not for construction. Contractor shall verify and be responsible for all dimensions and conditions of the job. Contractor shall be familiar with the site and conditions it presents. This office must be notified of any variations from the dimensions and conditions shown on this drawing. Shop drawings and details must be submitted to this office for approval prior to proceeding with fabrication. All copy shall be proofread by client and legal requirements checked by legal department.

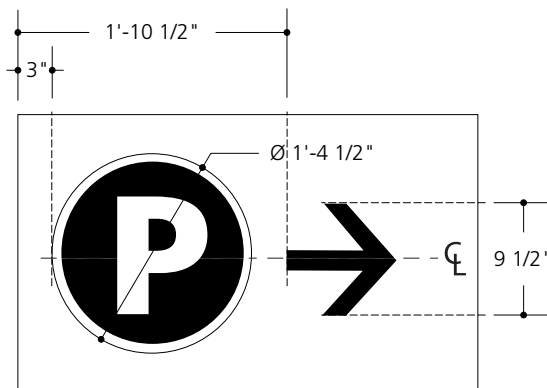

2 **Typical Layout Guidelines**
scale: 3/4"=1'-0"

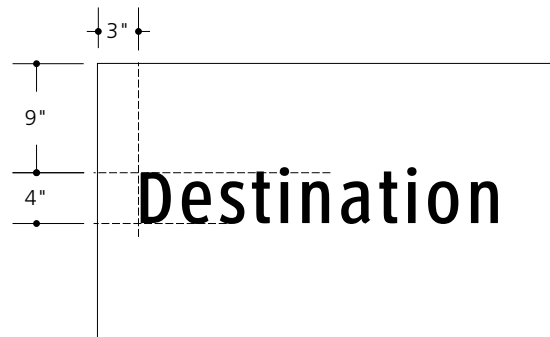

3 **Typical Layout Guidelines**
scale: 3/4"=1'-0"

PARK.2
PARKING DIRECTIONAL

All exposed surfaces shall have a anti-graffiti protectant. Painted surfaces will have a clear coating and vinyl surfaces shall have a clear vinyl over-lam as required by the paint and vinyl manufacturer.

All exposed fasteners shall be painted to match adjacent surface.

All sign structures shall be signed and sealed by a certified Texas structural engineer prior to fabrication.

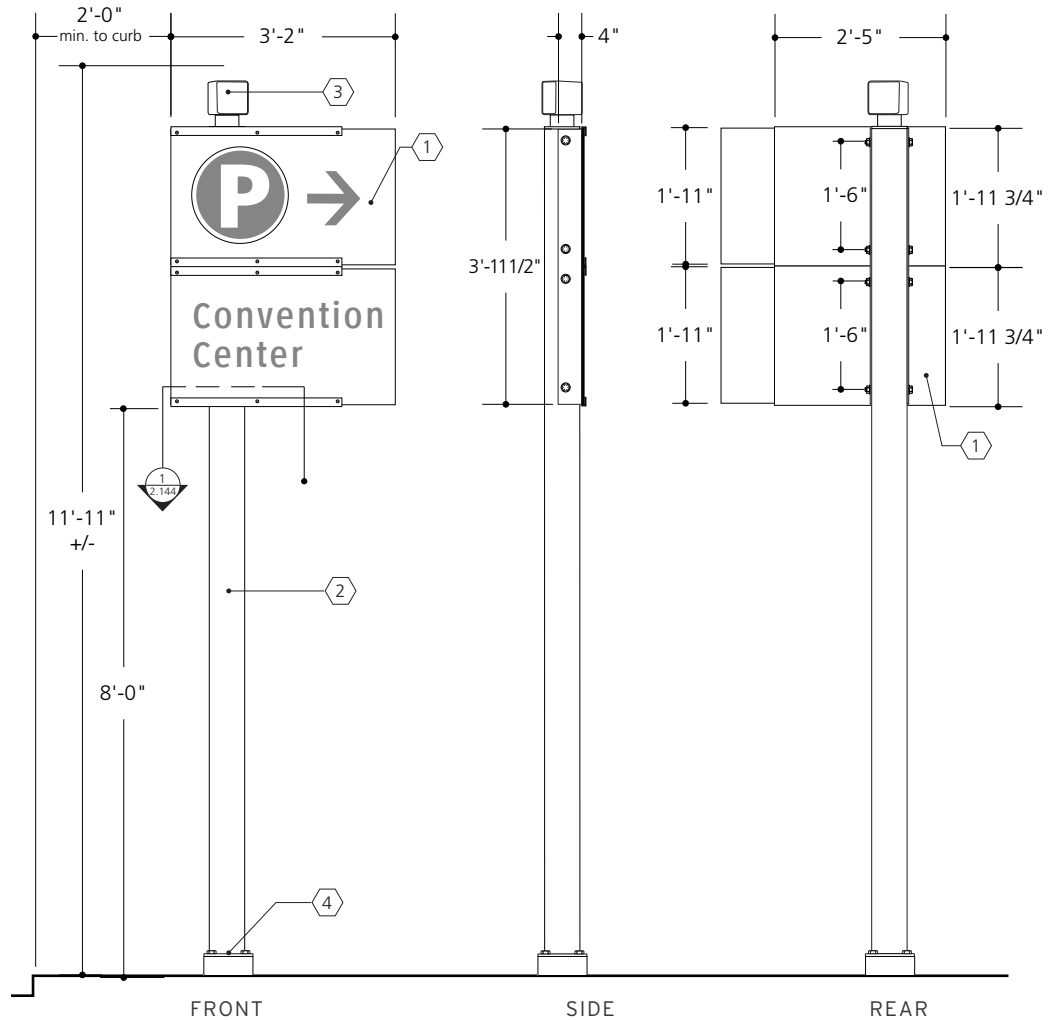

1 Elevations PARK.2
scale: 3/8"=1'-0"

- ① Modular sign panel assembly (see PART C: Construction Details for more detail)
- ② 6" x 1/4 wall alum tube upright
- ③ Handcrafted finial - mounted to upright cap assembly (see PART C: Construction Details, page 2.143).
- ④ Transpo Pole-Safe breakaway device with aluminum escutcheon cover (see PART C: Construction Details for different footer types). Verify all location conditions.

These drawings are meant for DESIGN INTENT ONLY and are not for construction. Contractor shall verify and be responsible for all dimensions and conditions of the job. Contractor shall be familiar with the site and conditions it presents. This office must be notified of any variations from the dimensions and conditions shown on this drawing. Shop drawings and details must be submitted to this office for approval prior to proceeding with fabrication. All copy shall be proofread by client and legal requirements checked by legal department.

PARK.2_LEFT
PARKING DIRECTIONAL

Parking directional signs are modular with panels that can be easily replaced. Signs can have 1-3 messages, and can hold either a graphic pictogram message or a text message.

Parking Directional signs can direct to a lot by name or include the destination the lot serves.

"Left-Mounted" versions are available for placement on opposite sides (left) of street.

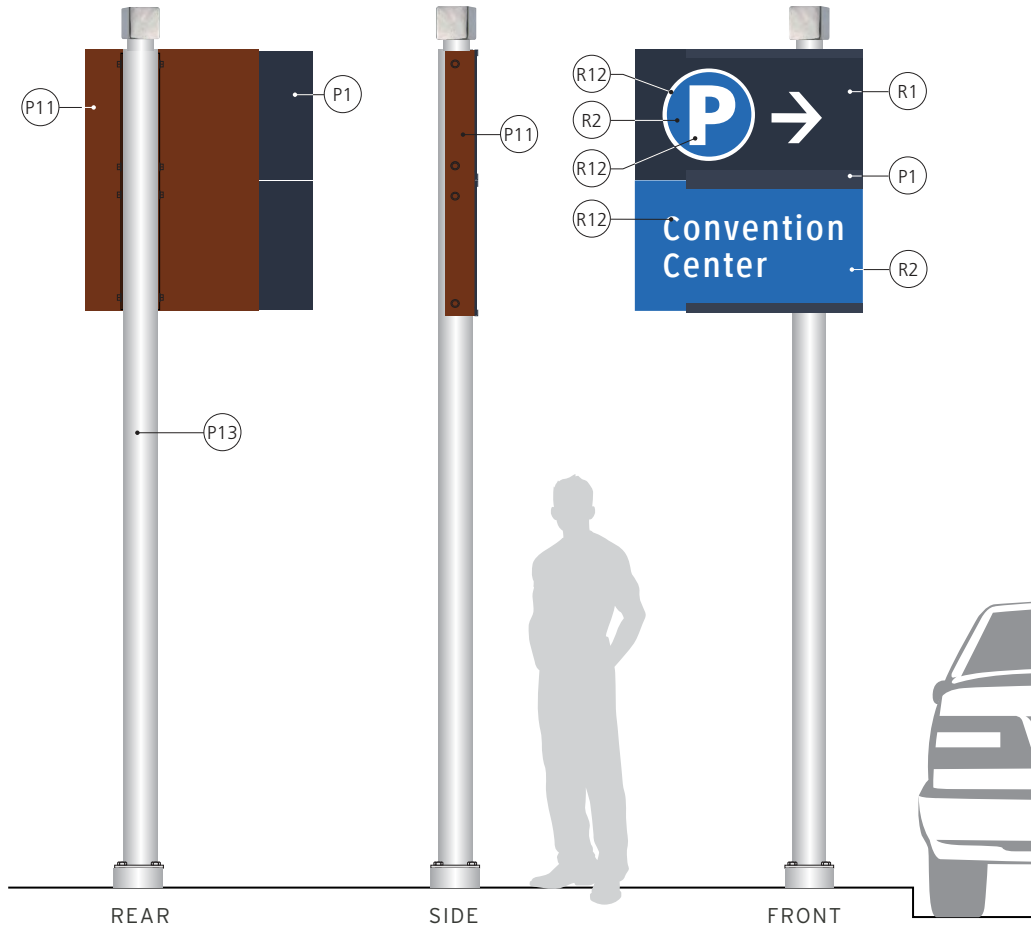

1 **Color Schedule PARK.2_left**
scale: 3/8"=1'-0"

These drawings are meant for DESIGN INTENT ONLY and are not for construction. Contractor shall verify and be responsible for all dimensions and conditions of the job. Contractor shall be familiar with the site and conditions it presents. This office must be notified of any variations from the dimensions and conditions shown on this drawing. Shop drawings and details must be submitted to this office for approval prior to proceeding with fabrication. All copy shall be proofread by client and legal requirements checked by legal department.

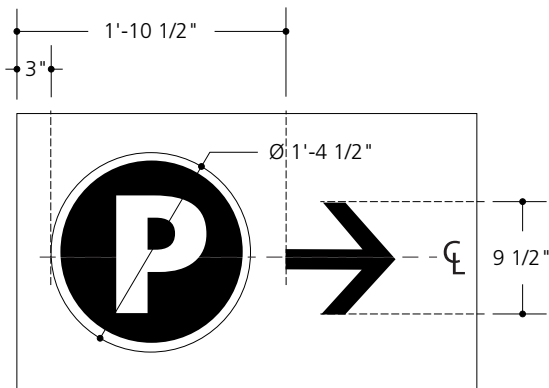

2 **Typical Layout Guidelines**
scale: 3/4"=1'-0"

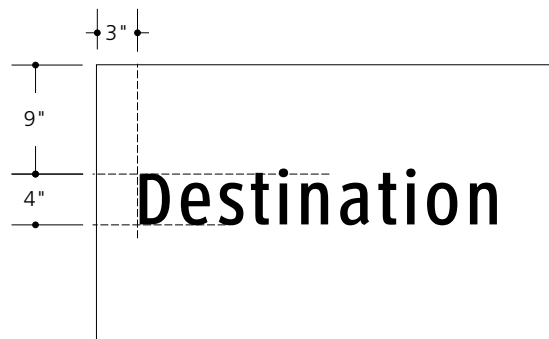

3 **Typical Layout Guidelines**
scale: 3/4"=1'-0"

PARK.2_LEFT
PARKING DIRECTIONAL

All exposed surfaces shall have a anti-graffiti protectant. Painted surfaces will have a clear coating and vinyl surfaces shall have a clear vinyl over-lam as required by the paint and vinyl manufacturer.

All exposed fasteners shall be painted to match adjacent surface.

All sign structures shall be signed and sealed by a certified Texas structural engineer prior to fabrication.

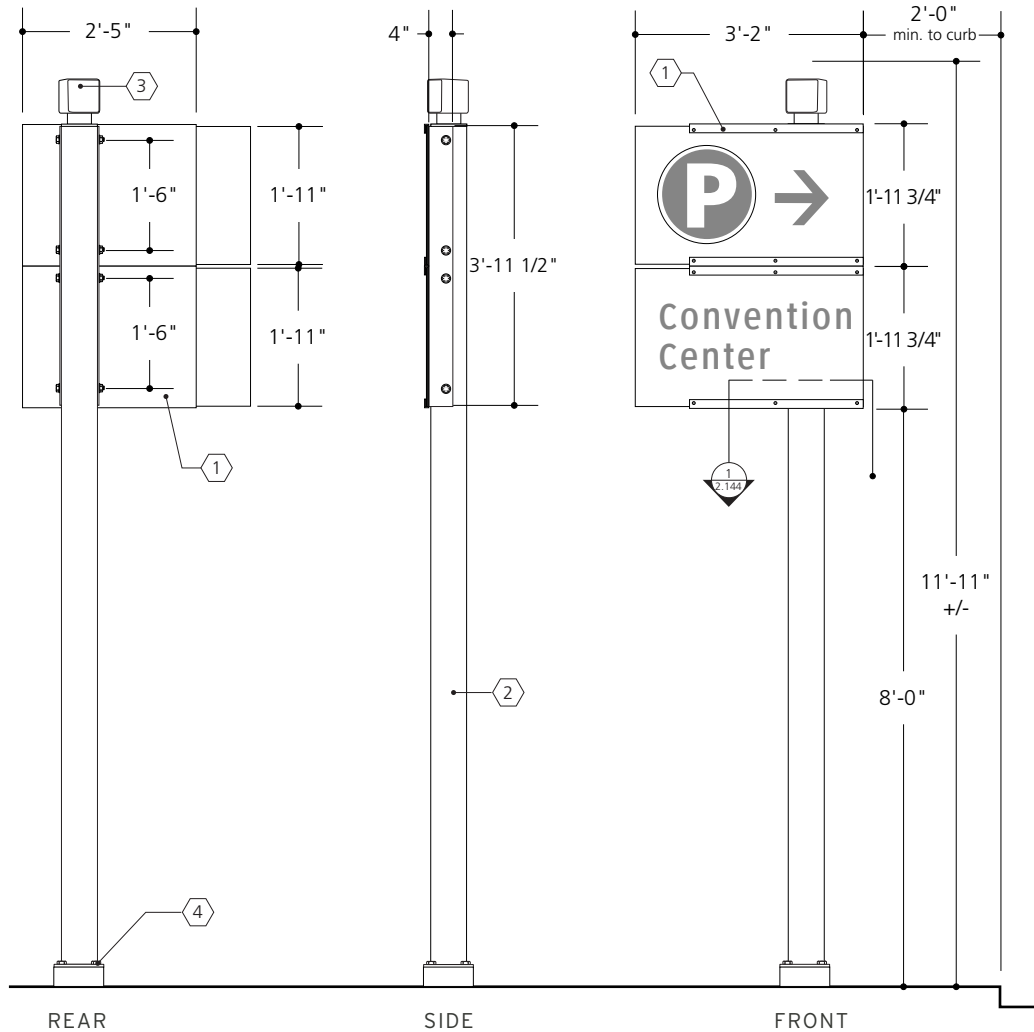

1 Elevations PARK.2 left
scale: 3/8"=1'-0"

- 1 Modular sign panel assembly (see PART C: Construction Details for more detail)
- 2 6" x 1/4 wall alum tube upright
- 3 Handcrafted finial - mounted to upright cap assembly (see PART C: Construction Details, page 2.143).
- 4 Transpo Pole-Safe breakaway device with aluminum escutcheon cover (see PART C: Construction Details for different footer types). Verify all location conditions.

These drawings are meant for DESIGN INTENT ONLY and are not for construction. Contractor shall verify and be responsible for all dimensions and conditions of the job. Contractor shall be familiar with the site and conditions it presents. This office must be notified of any variations from the dimensions and conditions shown on this drawing. Shop drawings and details must be submitted to this office for approval prior to proceeding with fabrication. All copy shall be proofread by client and legal requirements checked by legal department.

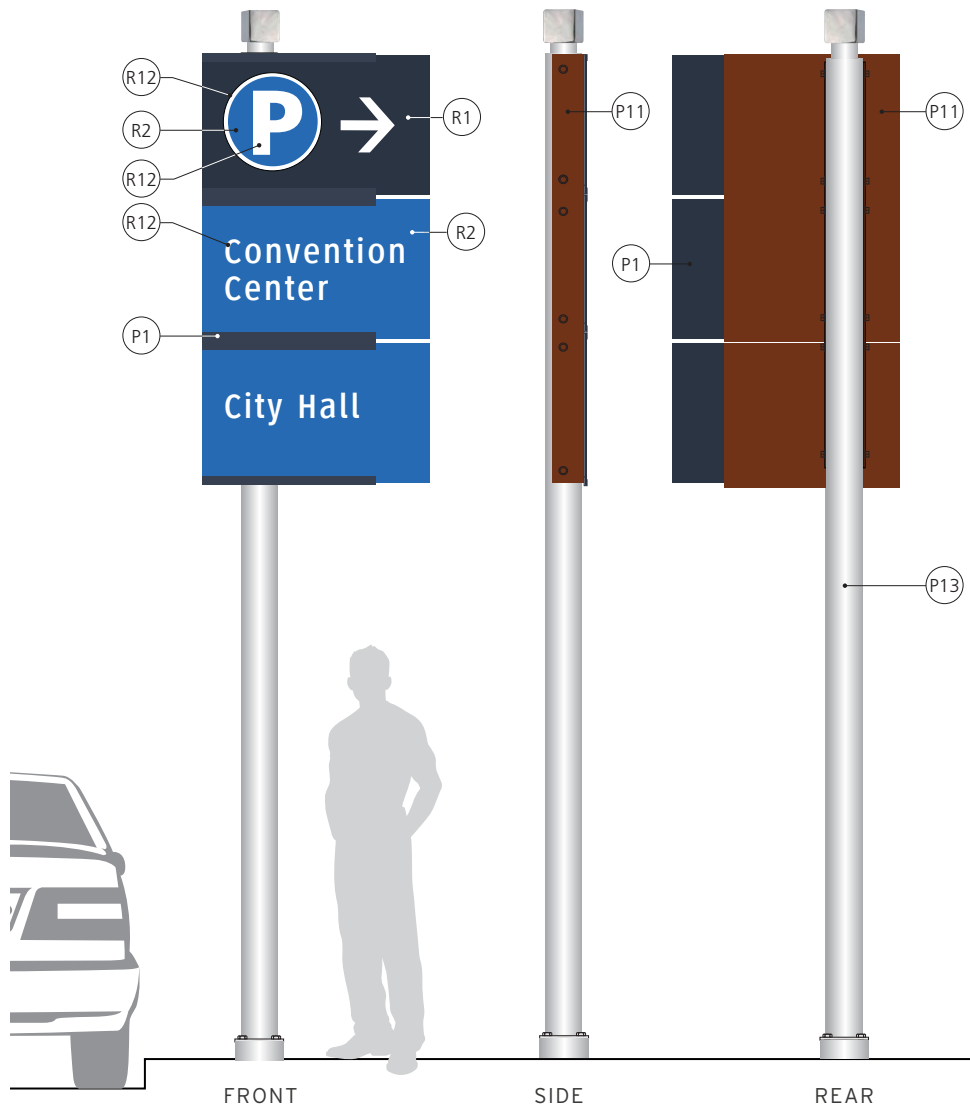

**PARK.3
PARKING DIRECTIONAL**

Parking directional signs are modular with panels that can be easily replaced. Signs can have 1-3 messages, and can hold either a graphic pictogram message or a text message.

Parking Directional signs can direct to a lot by name or include the destination the lot serves.

These drawings are meant for DESIGN INTENT ONLY and are not for construction. Contractor shall verify and be responsible for all dimensions and conditions of the job. Contractor shall be familiar with the site and conditions it presents. This office must be notified of any variations from the dimensions and conditions shown on this drawing. Shop drawings and details must be submitted to this office for approval prior to proceeding with fabrication. All copy shall be proofread by client and legal requirements checked by legal department.

1 **Color Schedule PARK.3**
scale: 3/8"=1'-0"

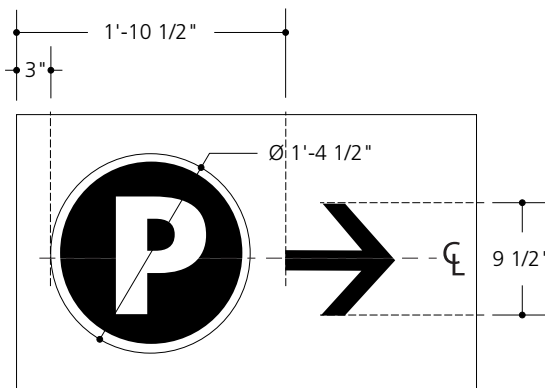

2 **Typical Layout Guidelines**
scale: 3/4"=1'-0"

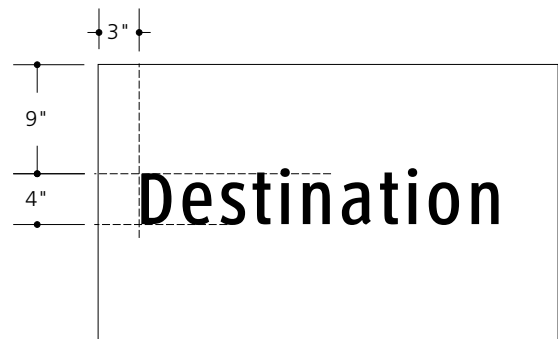

3 **Typical Layout Guidelines**
scale: 3/4"=1'-0"

PARK.3
PARKING DIRECTIONAL

All exposed surfaces shall have a anti-graffiti protectant. Painted surfaces will have a clear coating and vinyl surfaces shall have a clear vinyl over-lam as required by the paint and vinyl manufacturer.

All exposed fasteners shall be painted to match adjacent surface.

All sign structures shall be signed and sealed by a certified Texas structural engineer prior to fabrication.

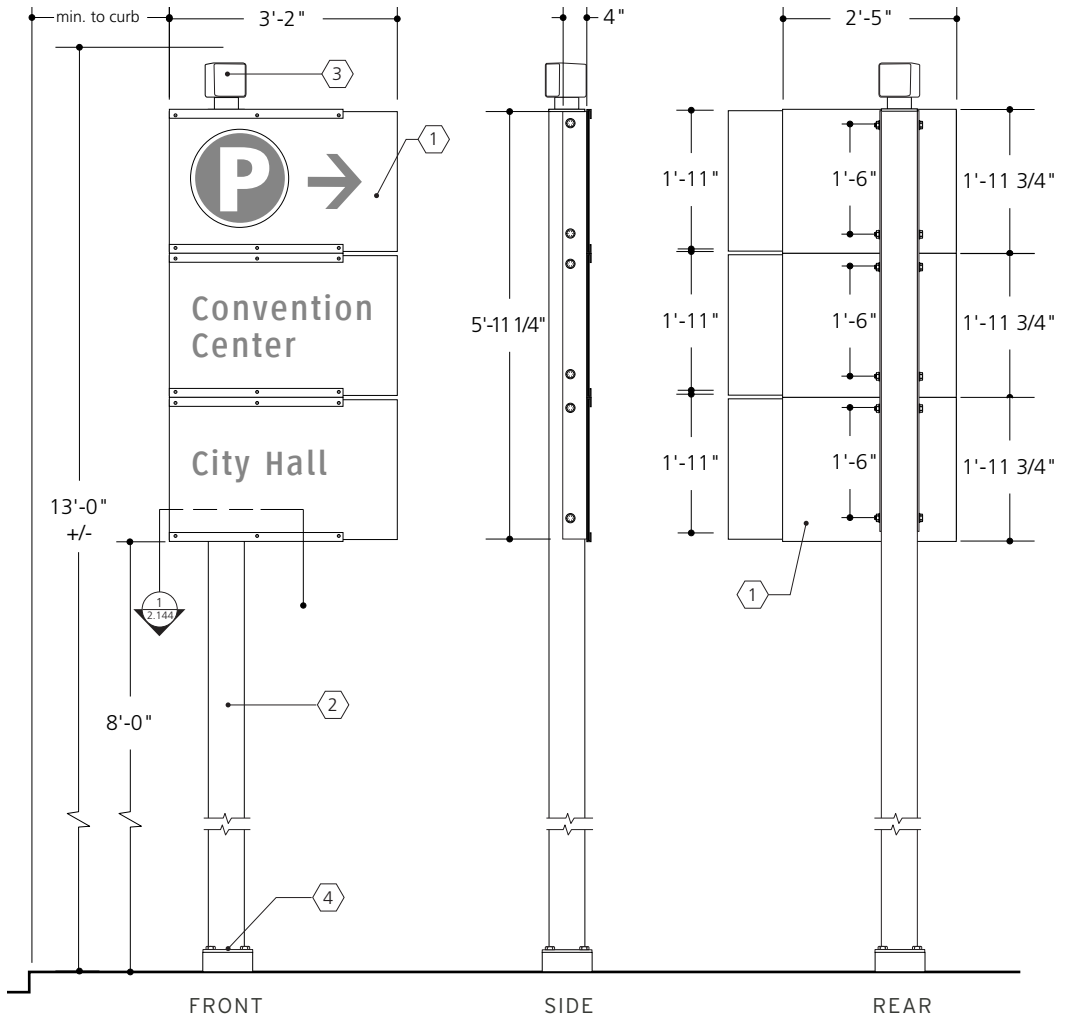

1 Elevations PARK.3
scale: 3/8"=1'-0"

- ① Modular sign panel assembly (see PART C: Construction Details for more detail)
- ② 6" x 1/4 wall alum tube upright
- ③ Handcrafted finial - mounted to upright cap assembly (see PART C: Construction Details, page 2.143).
- ④ Transpo Pole-Safe breakaway device with aluminum escutcheon cover (see PART C: Construction Details for different footer types). Verify all location conditions.

These drawings are meant for DESIGN INTENT ONLY and are not for construction. Contractor shall verify and be responsible for all dimensions and conditions of the job. Contractor shall be familiar with the site and conditions it presents. This office must be notified of any variations from the dimensions and conditions shown on this drawing. Shop drawings and details must be submitted to this office for approval prior to proceeding with fabrication. All copy shall be proofread by client and legal requirements checked by legal department.

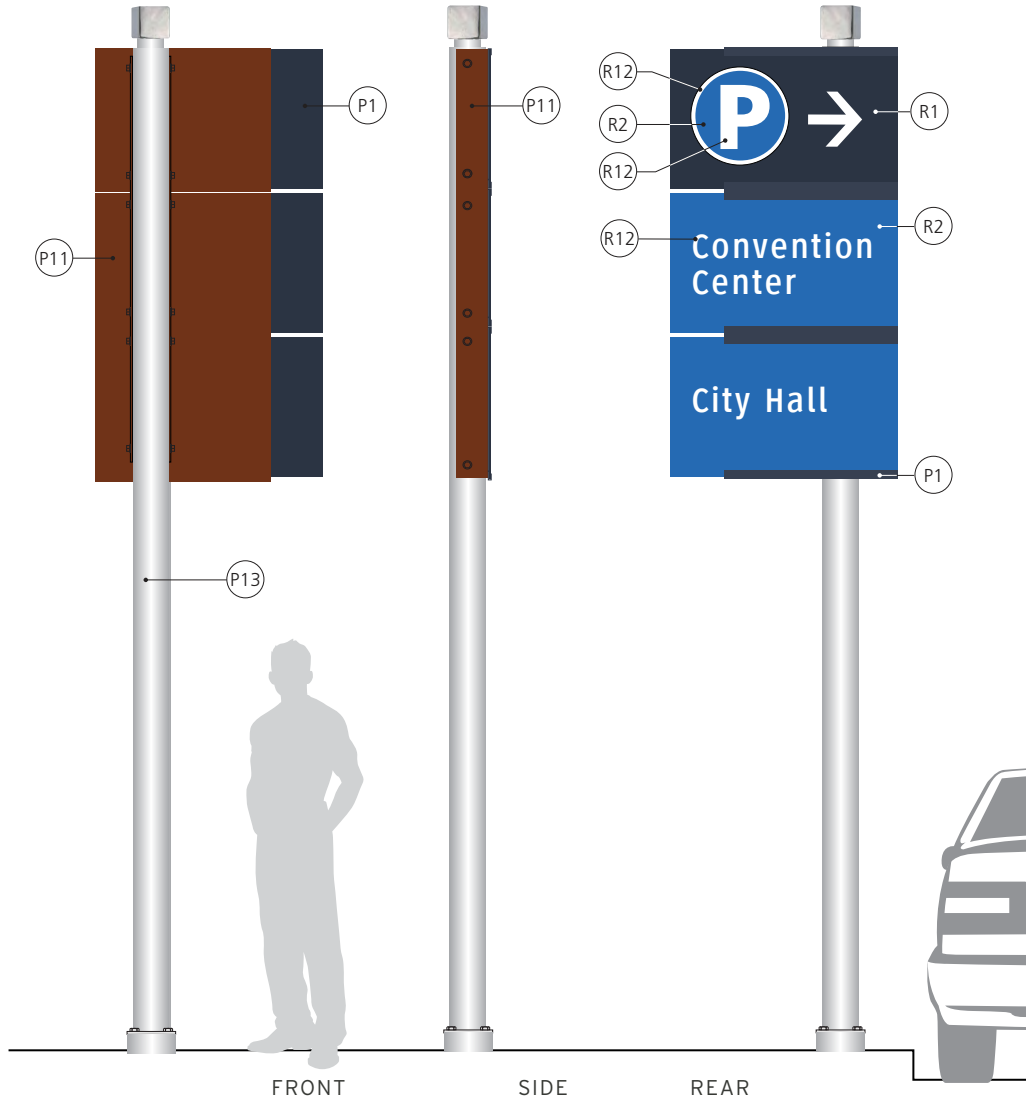

**PARK.3_LEFT
PARKING DIRECTIONAL
LEFT SIDE PANEL**

Parking directional signs are modular with panels that can be easily replaced. Signs can have 1-3 messages, and can hold either a graphic pictogram message or a text message.

Parking Directional signs can direct to a lot by name or include the destination the lot serves.

"Left-Mounted" versions are available for placement on opposite sides (left) of street.

These drawings are meant for DESIGN INTENT ONLY and are not for construction. Contractor shall verify and be responsible for all dimensions and conditions of the job. Contractor shall be familiar with the site and conditions it presents. This office must be notified of any variations from the dimensions and conditions shown on this drawing. Shop drawings and details must be submitted to this office for approval prior to proceeding with fabrication. All copy shall be proofread by client and legal requirements checked by legal department.

1 **Color Schedule PARK.3_left**
scale: 3/8"=1'-0"

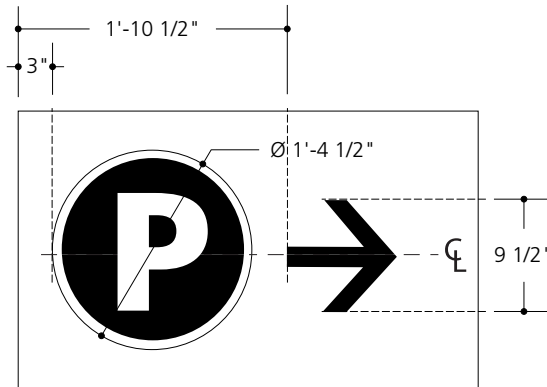

2 **Typical Layout Guidelines**
scale: 3/4"=1'-0"

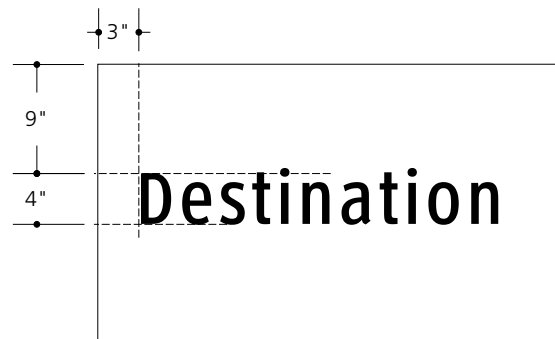

3 **Typical Layout Guidelines**
scale: 3/4"=1'-0"

PARK.3_LEFT
PARKING DIRECTIONAL

All exposed surfaces shall have a anti-graffiti protectant. Painted surfaces will have a clear coating and vinyl surfaces shall have a clear vinyl over-lam as required by the paint and vinyl manufacturer.

All exposed fasteners shall be painted to match adjacent surface.

All sign structures shall be signed and sealed by a certified Texas structural engineer prior to fabrication.

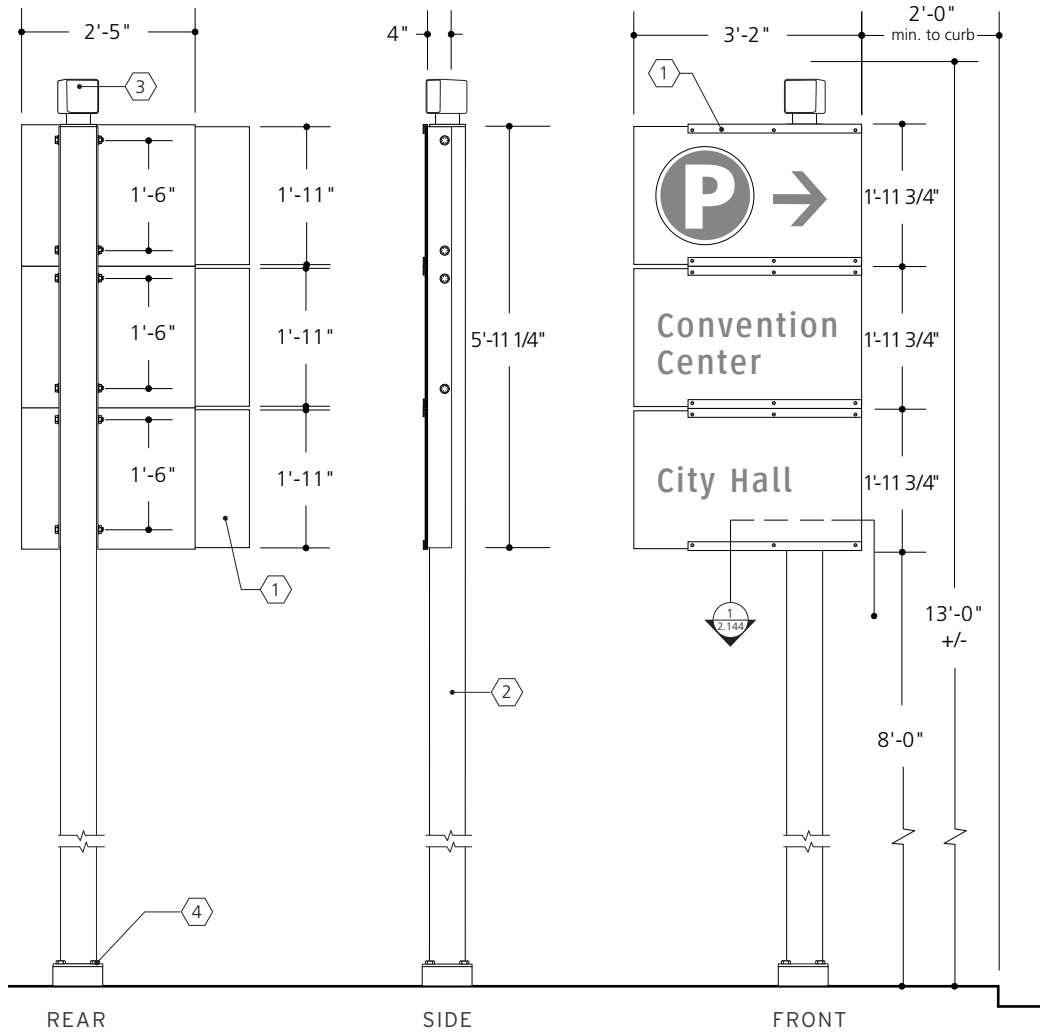

1 Elevations PARK.3 left
scale: 3/8"=1'-0"

- 1 Modular sign panel assembly (see PART C: Construction Details for more detail)
- 2 6" x 1/4 wall alum tube upright
- 3 Handcrafted finial - mounted to upright cap assembly (see PART C: Construction Details, page 2.143).
- 4 Transpo Pole-Safe breakaway device with aluminum escutcheon cover (see PART C: Construction Details for different footer types). Verify all location conditions.

These drawings are meant for DESIGN INTENT ONLY and are not for construction. Contractor shall verify and be responsible for all dimensions and conditions of the job. Contractor shall be familiar with the site and conditions it presents. This office must be notified of any variations from the dimensions and conditions shown on this drawing. Shop drawings and details must be submitted to this office for approval prior to proceeding with fabrication. All copy shall be proofread by client and legal requirements checked by legal department.

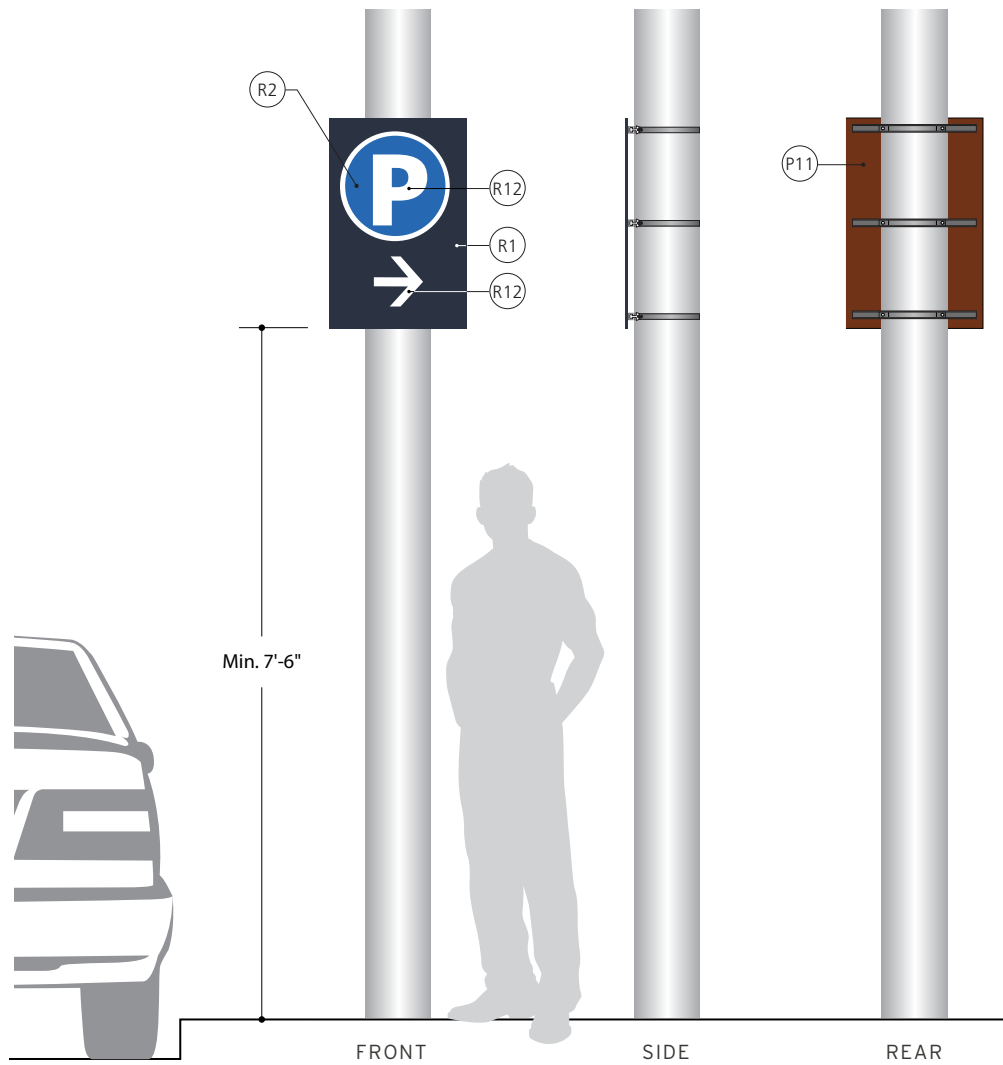

① Color Schedule TEMP.2
scale: 1/2"=1'-0"

**PARK.4
PARKING TRAILBLAZER**

Parking directional signs are modular with panels that can be easily replaced. Signs can have 1-3 messages, and can hold either a graphic pictogram message or a text message.

Parking Directional signs can direct to a lot by name or include the destination the lot serves.

Parking trailblazer signs can be mounted to existing lightpoles

These drawings are meant for DESIGN INTENT ONLY and are not for construction. Contractor shall verify and be responsible for all dimensions and conditions of the job. Contractor shall be familiar with the site and conditions it presents. This office must be notified of any variations from the dimensions and conditions shown on this drawing. Shop drawings and details must be submitted to this office for approval prior to proceeding with fabrication. All copy shall be proofread by client and legal requirements checked by legal department.

PARK.4
PARKING TRAILBLAZER

All exposed surfaces shall have an anti-graffiti protectant. Painted surfaces will have a clear coating and vinyl surfaces shall have a clear vinyl over-lam as required by the paint and vinyl manufacturer.

All exposed fasteners shall be painted to match adjacent surface.

All sign structures shall be signed and sealed by a certified Texas structural engineer prior to fabrication.

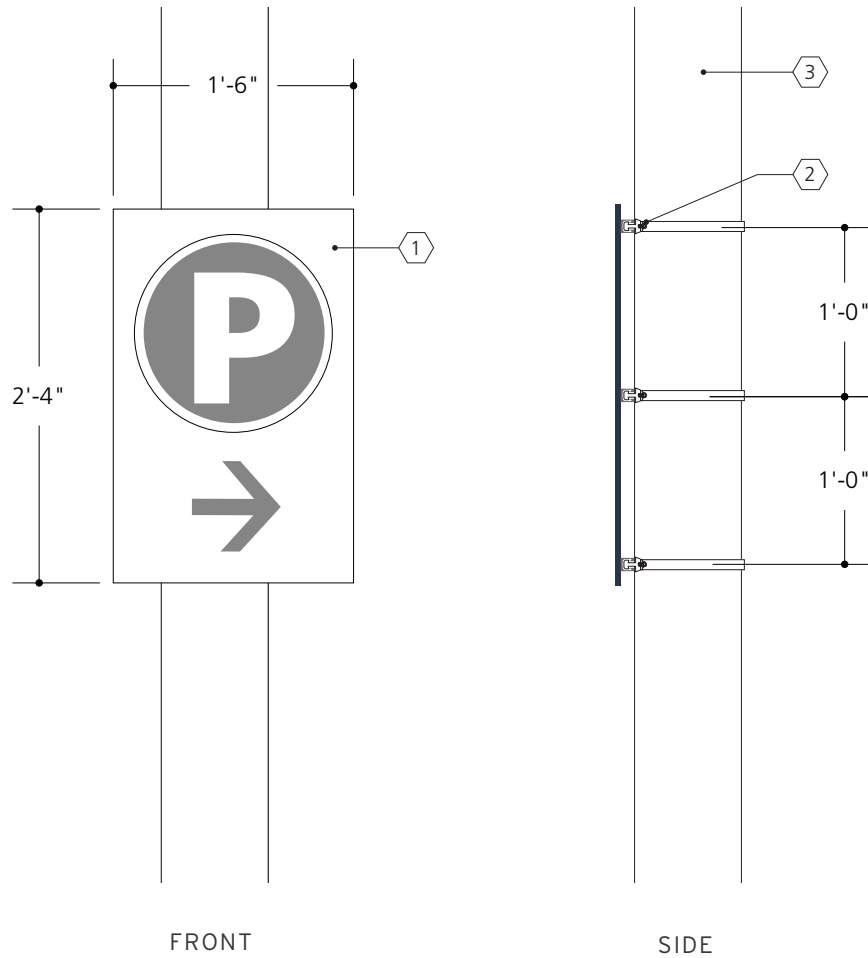

① **Elevations PARK.4**
scale: 3/4"=1'-0"

- ① 3/8" painted alum message panel-Applied Reflective Sheeting
- ② SignFix channel and strapping assembly - channels are welded to back of message panel. U-shaped stainless steel straps have quick-release bolt blocks set into channels. www.signfix.co.uk
- ③ Existing pole

These drawings are meant for DESIGN INTENT ONLY and are not for construction. Contractor shall verify and be responsible for all dimensions and conditions of the job. Contractor shall be familiar with the site and conditions it presents. This office must be notified of any variations from the dimensions and conditions shown on this drawing. Shop drawings and details must be submitted to this office for approval prior to proceeding with fabrication. All copy shall be proofread by client and legal requirements checked by legal department.

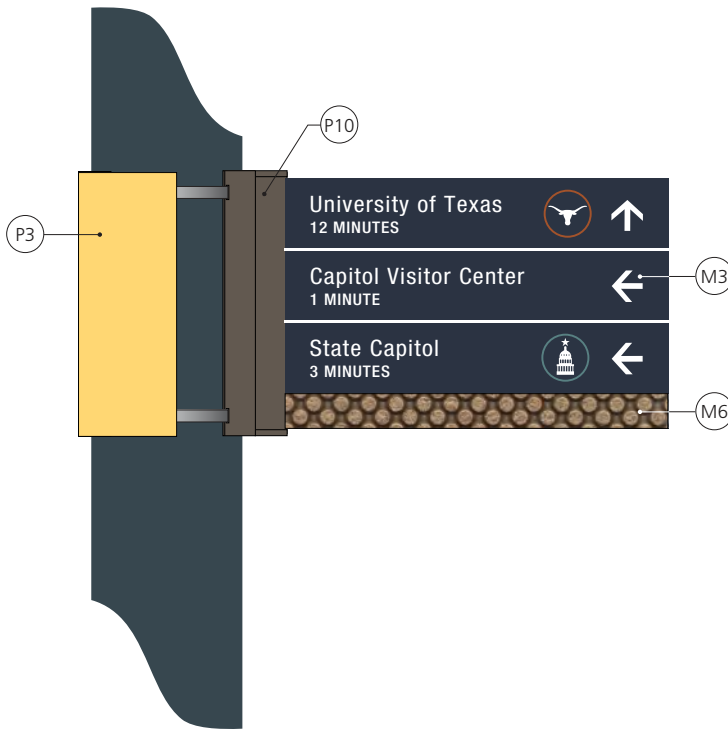

PDIR.3
PEDESTRIAN DIRECTIONAL -
3 MESSAGES / EXISTING
POLE

A series of pedestrian sign types have been developed to address various situations and communicate a variety of information.

DIRECTIONALS (BASIC):
 This sign type is mounted to an existing pole and provides direction to up to 3 destinations.

In addition to the attraction name and direction, the sign should also indicate the amount of time it takes to walk to that destination.

These signs can direct to typical destinations and attractions as well as parking garages and lots, and adjacent districts.

1 Color Schedule - PDIR.3
 scale: 1"=1'-0"

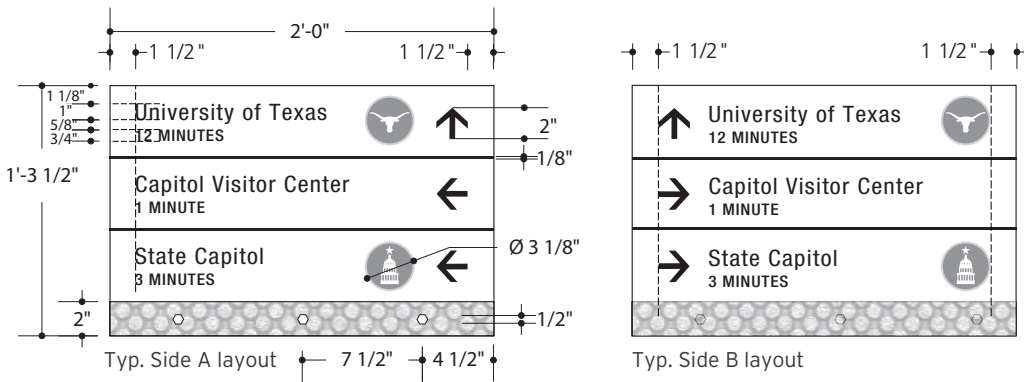

2 Typical Layout Guidelines - PDIR
 scale: 1"=1'-0"

These drawings are meant for DESIGN INTENT ONLY and are not for construction. Contractor shall verify and be responsible for all dimensions and conditions of the job. Contractor shall be familiar with the site and conditions it presents. This office must be notified of any variations from the dimensions and conditions shown on this drawing. Shop drawings and details must be submitted to the City of Austin for approval prior to proceeding with fabrication. All copy shall be proofread by the City of Austin and legal requirements checked by legal department.

PDIR.3
PEDESTRIAN DIRECTIONAL -
3 MESSAGES

All exposed surfaces shall have a anti-graffiti protectant. Painted surfaces will have a clear coating and vinyl surfaces shall have a clear vinyl over-lam as required by the paint and vinyl manufacturer.

All exposed fasteners shall be painted to match adjacent surface.

All sign structures shall be signed and sealed by a certified Texas structural engineer prior to fabrication.

Contractor shall be familiar with all mounting and field conditions including; pole size, obstructions, mounting heights, structural integrity and all other conditions that may affect the fabrication, installation and long-term lifespan of the sign, bracket and other components.

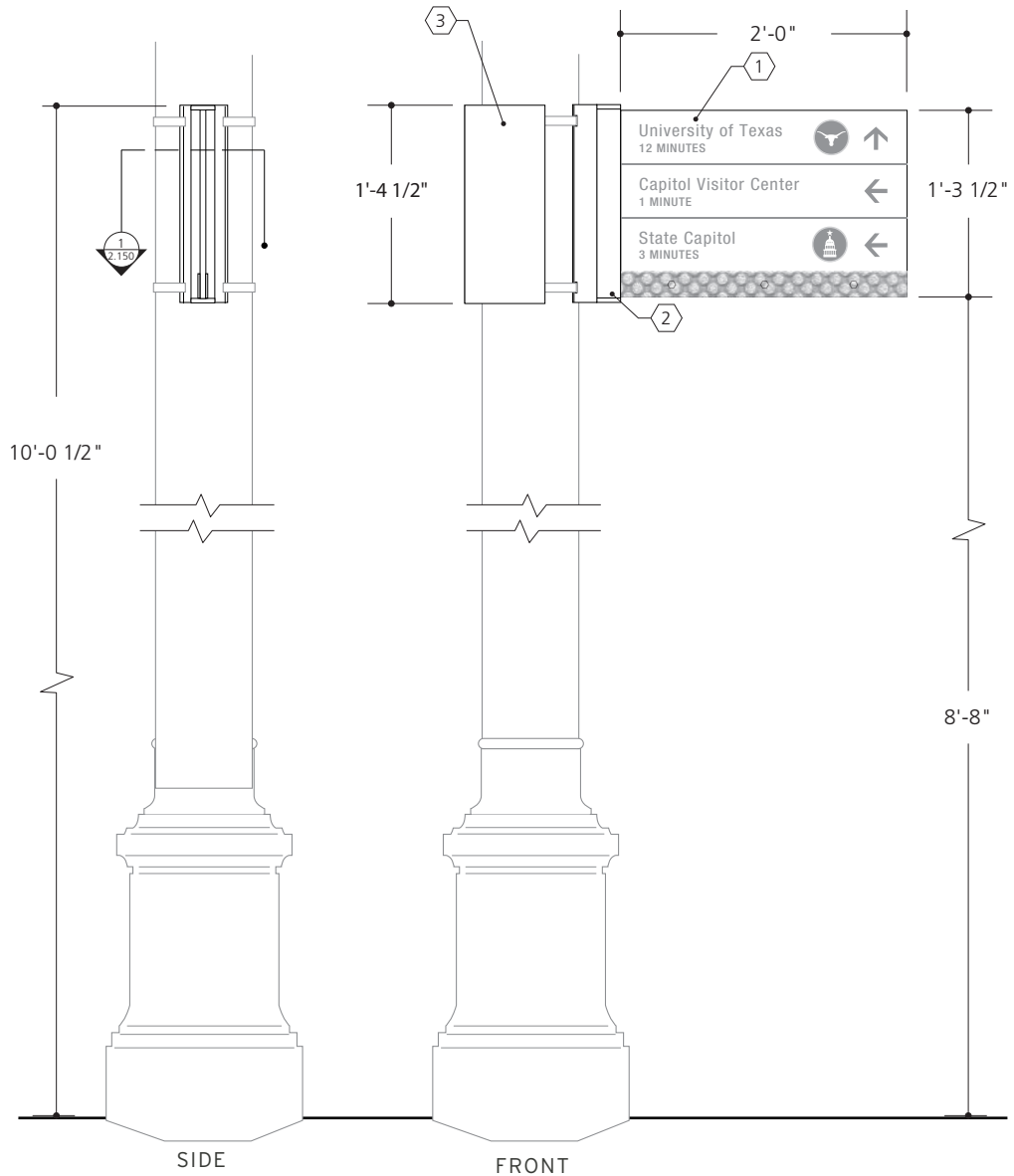

1 Elevations PDIR.3
scale: 3/4"=1'-0"

- 1** 1/2" thick hi-resolution double-faced phenolic resin message panel.
- 2** Sign structure assembled from SignComp parts (see PART C: Construction Details for more detail).
- 3** Sign is mounted on existing city light poles with 3/4" Band-fast with Color-It polyester coating to match existing light post finish. Verify all location conditions.

These drawings are meant for DESIGN INTENT ONLY and are not for construction. Contractor shall verify and be responsible for all dimensions and conditions of the job. Contractor shall be familiar with the site and conditions it presents. This office must be notified of any variations from the dimensions and conditions shown on this drawing. Shop drawings and details must be submitted to this office for approval prior to proceeding with fabrication. All copy shall be proofread by client and legal requirements checked by legal department.

PDIR.3A
PEDESTRIAN DIRECTIONAL -
3 MESSAGES / NEW POLE

A series of pedestrian sign types have been developed to address various situations and communicate a variety of information.

DIRECTIONALS (BASIC):
 This sign type is mounted to an existing pole and provides direction to up to 3 destinations.

In addition to the attraction name and direction, the sign should also indicate the amount of time it takes to walk to that destination.

These signs can direct to typical destinations and attractions as well as parking garages and lots, and adjacent districts.

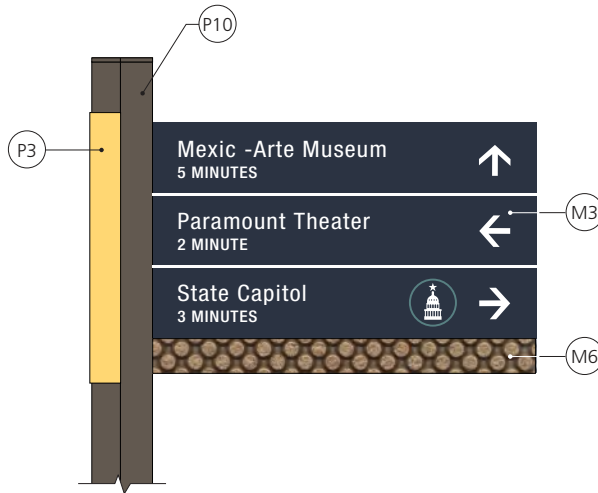

1 Color Schedule - PDIR.3a
 scale: 1"=1'-0"

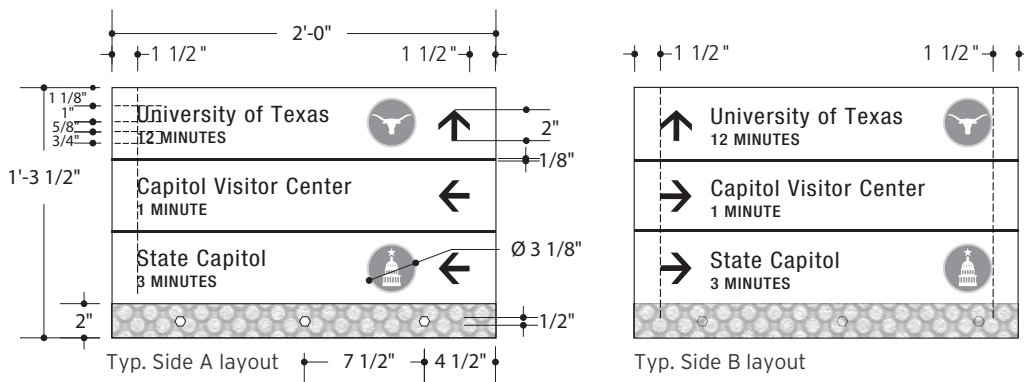

2 Typical Layout Guidelines - PDIR
 scale: 1"=1'-0"

These drawings are meant for DESIGN INTENT ONLY and are not for construction. Contractor shall verify and be responsible for all dimensions and conditions of the job. Contractor shall be familiar with the site and conditions it presents. This office must be notified of any variations from the dimensions and conditions shown on this drawing. Shop drawings and details must be submitted to the City of Austin for approval prior to proceeding with fabrication. All copy shall be proofread by the City of Austin and legal requirements checked by legal department.

PDIR.3A
PEDESTRIAN DIRECTIONAL -
3 MESSAGES / NEW POLE

All exposed surfaces shall have an anti-graffiti protectant. Painted surfaces will have a clear coating and vinyl surfaces shall have a clear vinyl over-lam as required by the paint and vinyl manufacturer.

All exposed fasteners shall be painted to match adjacent surface.

All sign structures shall be signed and sealed by a certified Texas structural engineer prior to fabrication.

Contractor shall be familiar with all mounting and field conditions including; pole size, obstructions, mounting heights, structural integrity and all other conditions that may affect the fabrication, installation and long-term lifespan of the sign, bracket and other components.

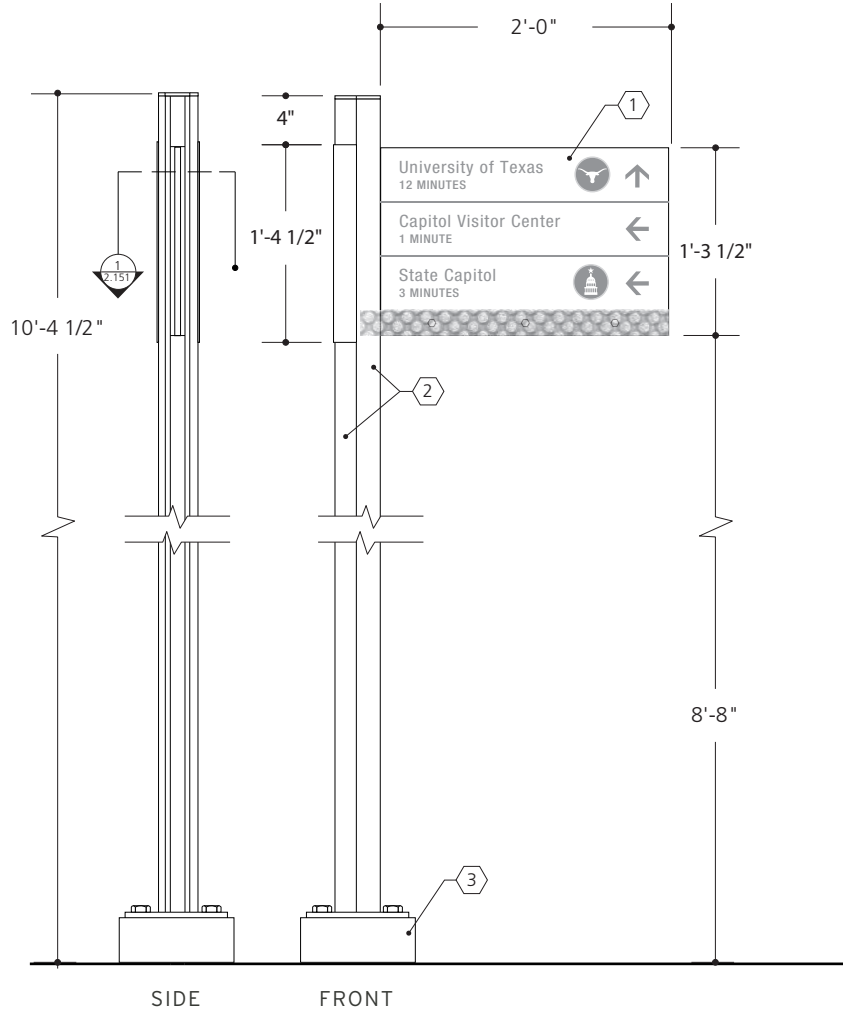

These drawings are meant for DESIGN INTENT ONLY and are not for construction. Contractor shall verify and be responsible for all dimensions and conditions of the job. Contractor shall be familiar with the site and conditions it presents. This office must be notified of any variations from the dimensions and conditions shown on this drawing. Shop drawings and details must be submitted to this office for approval prior to proceeding with fabrication. All copy shall be proofread by client and legal requirements checked by legal department.

1 Elevations PDIR.3a
 scale: 3/4"=1'-0"

- 1 1/2" thick hi-resolution double-faced phenolic resin message panel
- 2 Sign structure assembled from SignComp parts (see PART C: Construction Details for more detail).
- 3 Transpo Pole-Safe breakaway device with aluminum escutcheon cover (see PART C: Construction Details for different footer types). Verify all location conditions.

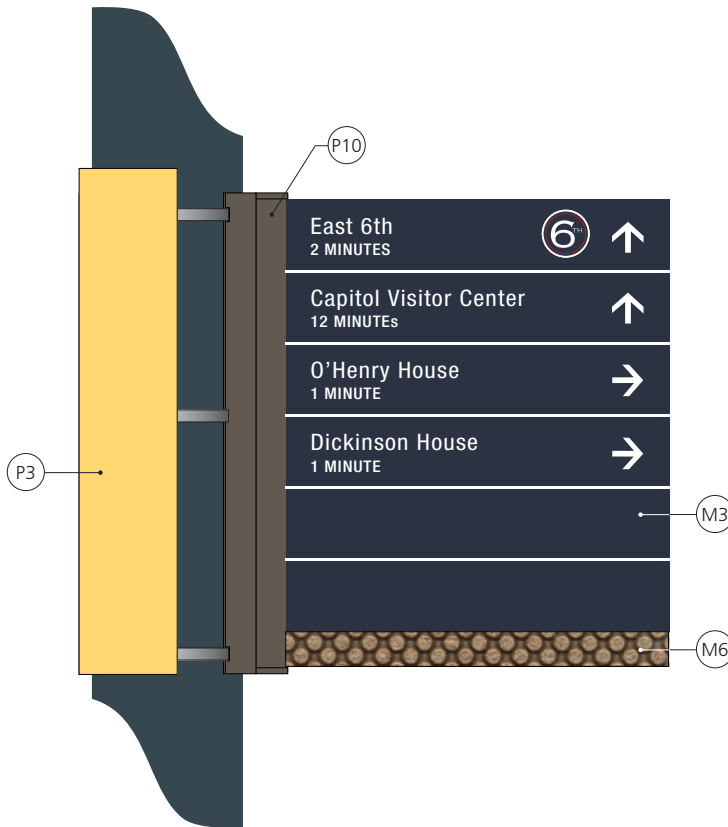

PDIR.6
PEDESTRIAN DIRECTIONAL -
6 MESSAGES / EXISTING
POLE

A series of pedestrian sign types have been developed to address various situations and communicate a variety of information.

DIRECTIONALS (BASIC):
 This sign type is mounted to an existing pole and provides direction to up to 6 destinations.

In addition to the attraction name and direction, the sign should also indicate the amount of time it takes to walk to that destination.

These signs can direct to typical destinations and attractions as well as parking garages and lots, and adjacent districts.

1 Color Schedule - PDIR.6
 scale: 1"=1'-0"

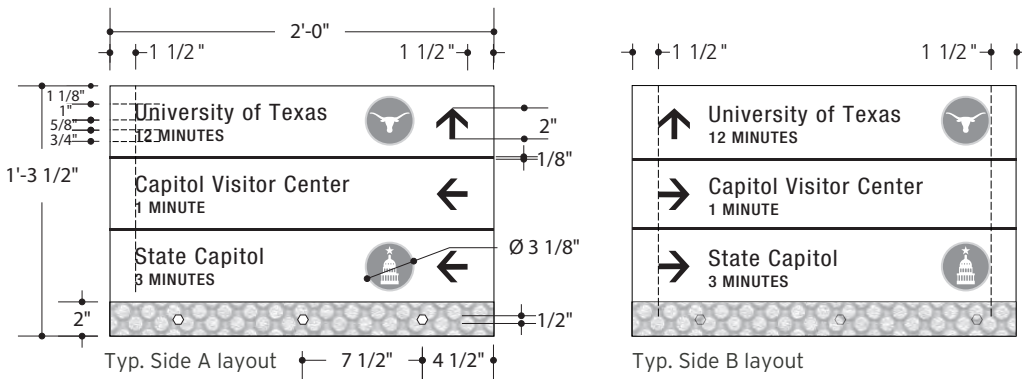

2 Typical Layout Guidelines - PDIR
 scale: 1"=1'-0"

These drawings are meant for DESIGN INTENT ONLY and are not for construction. Contractor shall verify and be responsible for all dimensions and conditions of the job. Contractor shall be familiar with the site and conditions it presents. This office must be notified of any variations from the dimensions and conditions shown on this drawing. Shop drawings and details must be submitted to the City of Austin for approval prior to proceeding with fabrication. All copy shall be proofread by the City of Austin and legal requirements checked by legal department.

PDIR.6
PEDESTRIAN DIRECTIONAL -
6 MESSAGES

All exposed surfaces shall have an anti-graffiti protectant. Painted surfaces will have a clear coating and vinyl surfaces shall have a clear vinyl over-lam as required by the paint and vinyl manufacturer.

All exposed fasteners shall be painted to match adjacent surface.

All sign structures shall be signed and sealed by a certified Texas structural engineer prior to fabrication.

Contractor shall be familiar with all mounting and field conditions including; pole size, obstructions, mounting heights, structural integrity and all other conditions that may affect the fabrication, installation and long-term lifespan of the sign, bracket and other components.

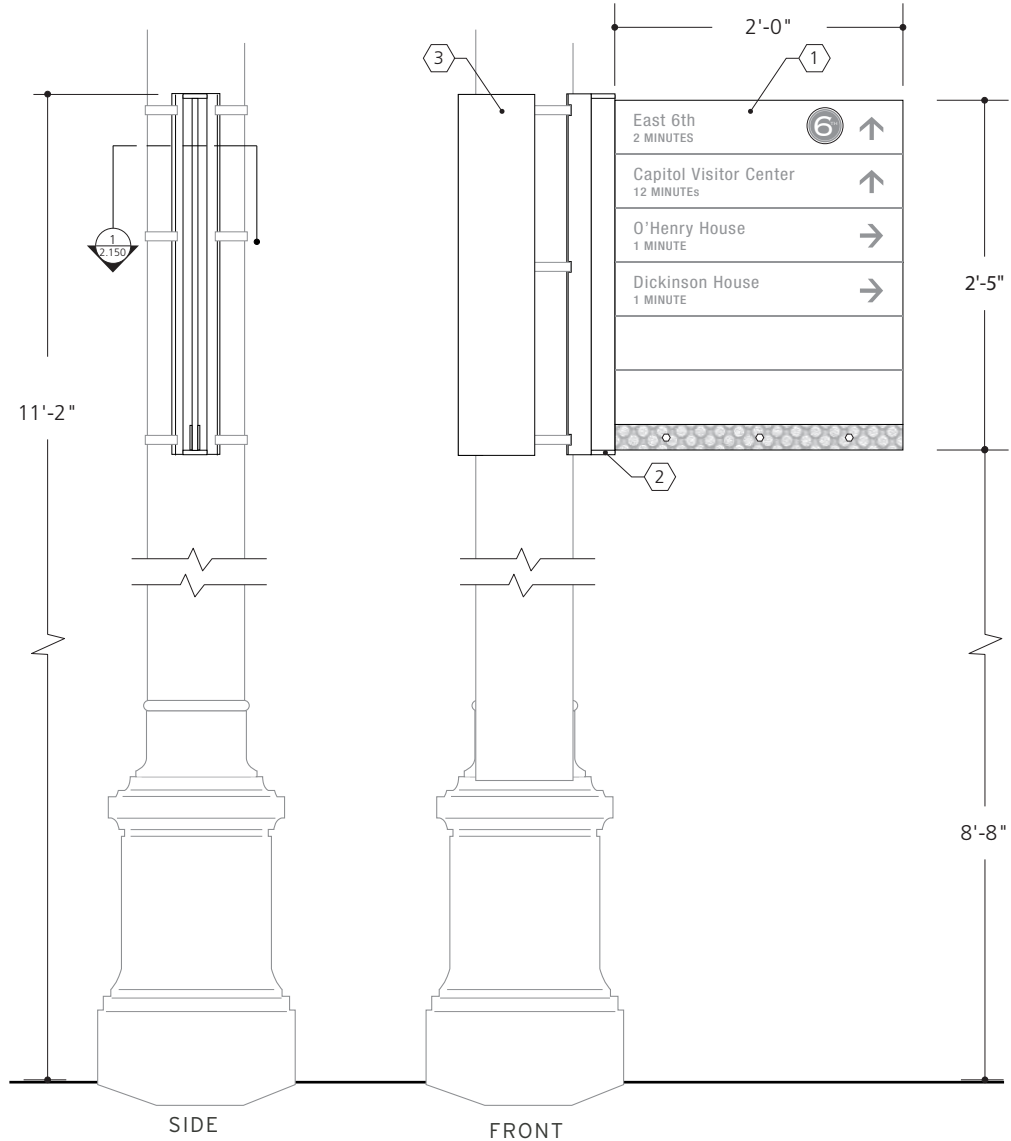

1 Elevations PDIR.6
 scale: 3/4"=1'-0"

These drawings are meant for DESIGN INTENT ONLY and are not for construction. Contractor shall verify and be responsible for all dimensions and conditions of the job. Contractor shall be familiar with the site and conditions it presents. This office must be notified of any variations from the dimensions and conditions shown on this drawing. Shop drawings and details must be submitted to this office for approval prior to proceeding with fabrication. All copy shall be proofread by client and legal requirements checked by legal department.

- 1 1/2" thick hi-resolution double-faced phenolic resin message panel
- 2 Sign structure assembled from SignComp parts (see PART C: Construction Details for more detail).
- 3 Sign is mounted on existing city light poles with 3/4" Band-fast with Color-It polyester coating to match existing light post finish. Verify all location conditions.

PDIR.6A
PEDESTRIAN DIRECTIONAL -
6 MESSAGES / NEW POLE

A series of pedestrian sign types have been developed to address various situations and communicate a variety of information.

DIRECTIONALS (BASIC):
 This sign type is mounted to an existing pole and provides direction to up to 6 destinations.

In addition to the attraction name and direction, the sign should also indicate the amount of time it takes to walk to that destination.

These signs can direct to typical destinations and attractions as well as parking garages and lots, and adjacent districts.

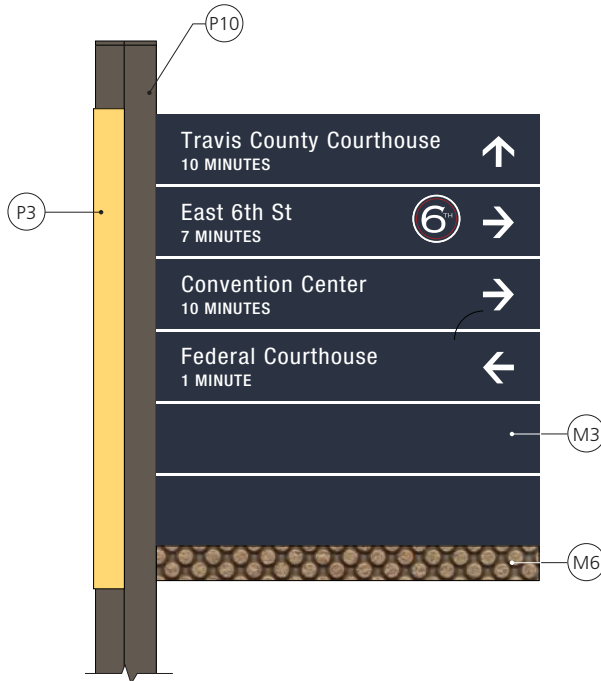

1 **Color Schedule - PDIR.6a**
 scale: 1"=1'-0"

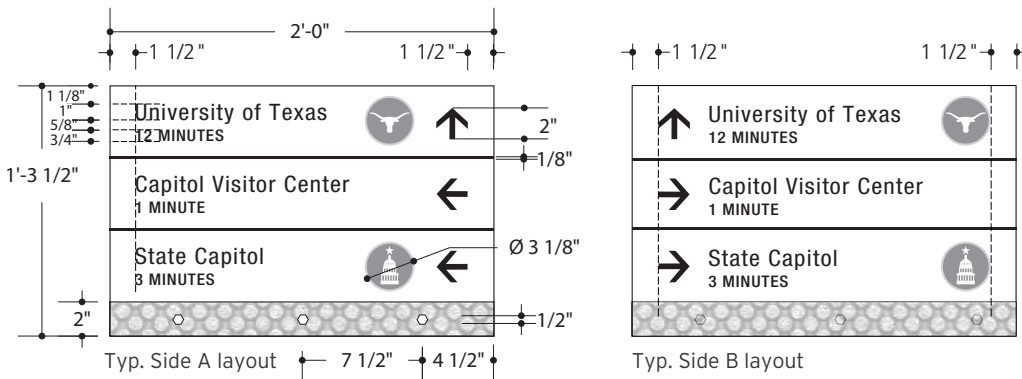

These drawings are meant for DESIGN INTENT ONLY and are not for construction. Contractor shall verify and be responsible for all dimensions and conditions of the job. Contractor shall be familiar with the site and conditions it presents. This office must be notified of any variations from the dimensions and conditions shown on this drawing. Shop drawings and details must be submitted to the City of Austin for approval prior to proceeding with fabrication. All copy shall be proofread by the City of Austin and legal requirements checked by legal department.

2 **Typical Layout Guidelines - PDIR**
 scale: 1"=1'-0"

PDIR.6A
PEDESTRIAN DIRECTIONAL -
6 MESSAGES / NEW POLE

All exposed surfaces shall have an anti-graffiti protectant. Painted surfaces will have a clear coating and vinyl surfaces shall have a clear vinyl over-lam as required by the paint and vinyl manufacturer.

All exposed fasteners shall be painted to match adjacent surface.

All sign structures shall be signed and sealed by a certified Texas structural engineer prior to fabrication.

Contractor shall be familiar with all mounting and field conditions including; pole size, obstructions, mounting heights, structural integrity and all other conditions that may affect the fabrication, installation and long-term lifespan of the sign, bracket and other components.

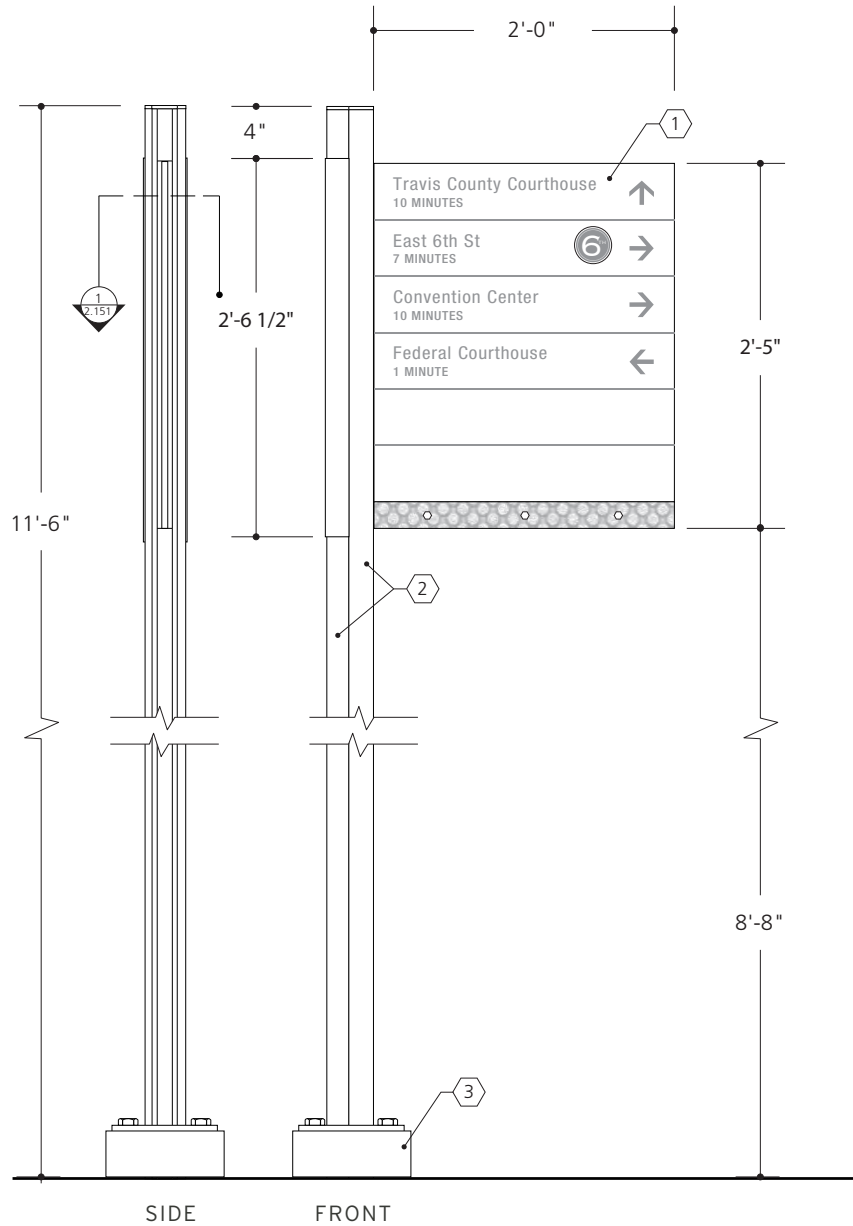

These drawings are meant for DESIGN INTENT ONLY and are not for construction. Contractor shall verify and be responsible for all dimensions and conditions of the job. Contractor shall be familiar with the site and conditions it presents. This office must be notified of any variations from the dimensions and conditions shown on this drawing. Shop drawings and details must be submitted to this office for approval prior to proceeding with fabrication. All copy shall be proofread by client and legal requirements checked by legal department.

1 Elevations PDIR.6a
 scale: 3/4"=1'-0"

- 1 1/2" thick hi-resolution double-faced phenolic resin message panel
- 2 Sign structure assembled from SignComp parts (see PART C: Construction Details for more detail).
- 3 Transpo Pole-Safe breakaway device with aluminum escutcheon cover (see PART C: Construction Details for different footer types). Verify all location conditions.

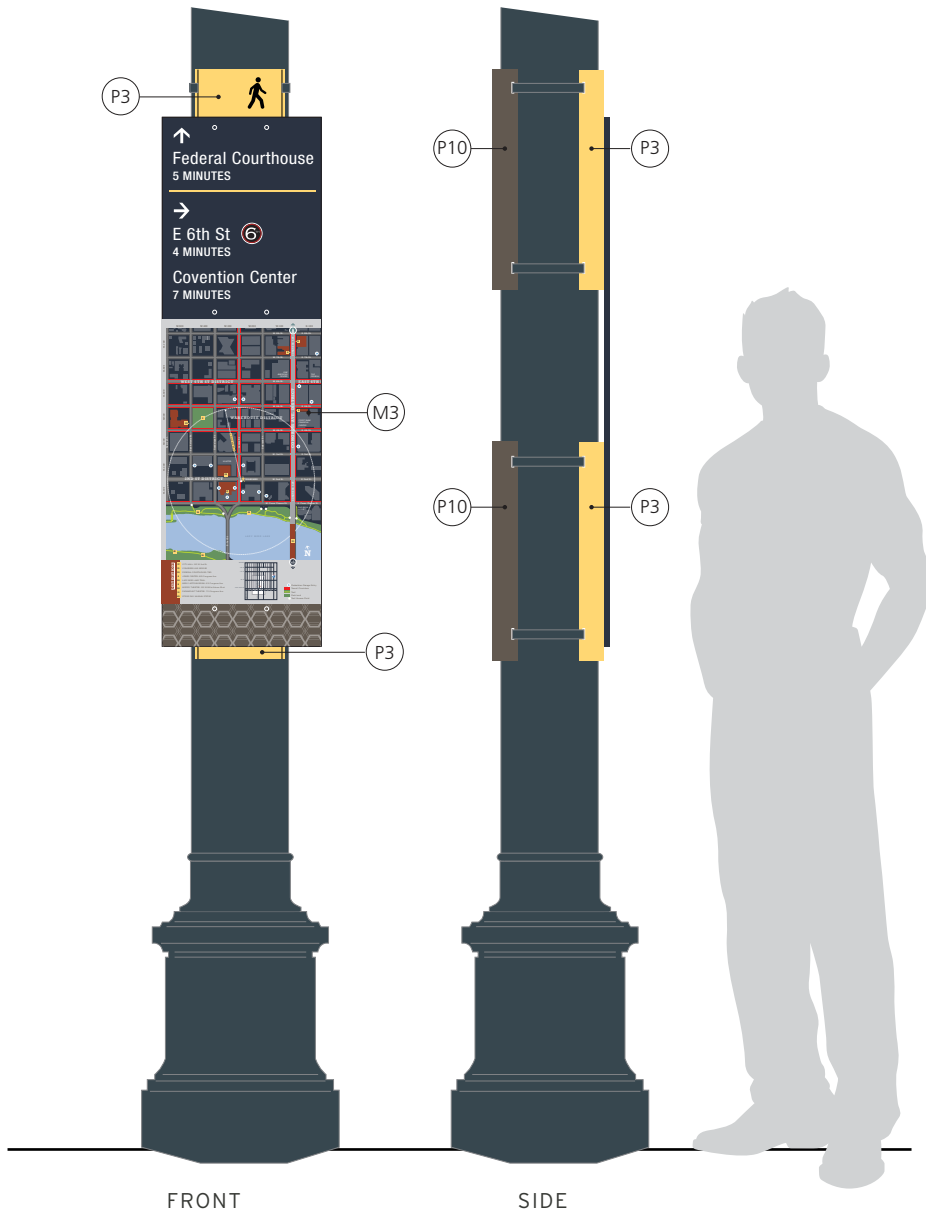

1 Color Schedule - PMAP.1
scale: 3/4"=1'-0"

PMAP.1
PEDESTRIAN MAP

A series of pedestrian sign types have been developed to address various situations and communicate a variety of information.

MAPS:
In situations where orientation would assist a visitor, signs are available to display a map graphic. The "heads-up" map includes major landmarks and a 5 and 10 minute walk radius.

Signs can be mounted on existing posts or freestanding.

These drawings are meant for DESIGN INTENT ONLY and are not for construction. Contractor shall verify and be responsible for all dimensions and conditions of the job. Contractor shall be familiar with the site and conditions it presents. This office must be notified of any variations from the dimensions and conditions shown on this drawing. Shop drawings and details must be submitted to the City of Austin for approval prior to proceeding with fabrication. All copy shall be proofread by the City of Austin and legal requirements checked by legal department.

PMAP.1
PEDESTRIAN MAP

All exposed surfaces shall have an anti-graffiti protectant. Painted surfaces will have a clear coating and vinyl surfaces shall have a clear vinyl over-lam as required by the paint and vinyl manufacturer.

All exposed fasteners shall be painted to match adjacent surface.

All sign structures shall be signed and sealed by a certified Texas structural engineer prior to fabrication.

Contractor shall be familiar with all mounting and field conditions including; pole size, obstructions, mounting heights, structural integrity and all other conditions that may affect the fabrication, installation and long-term lifespan of the sign, bracket and other components.

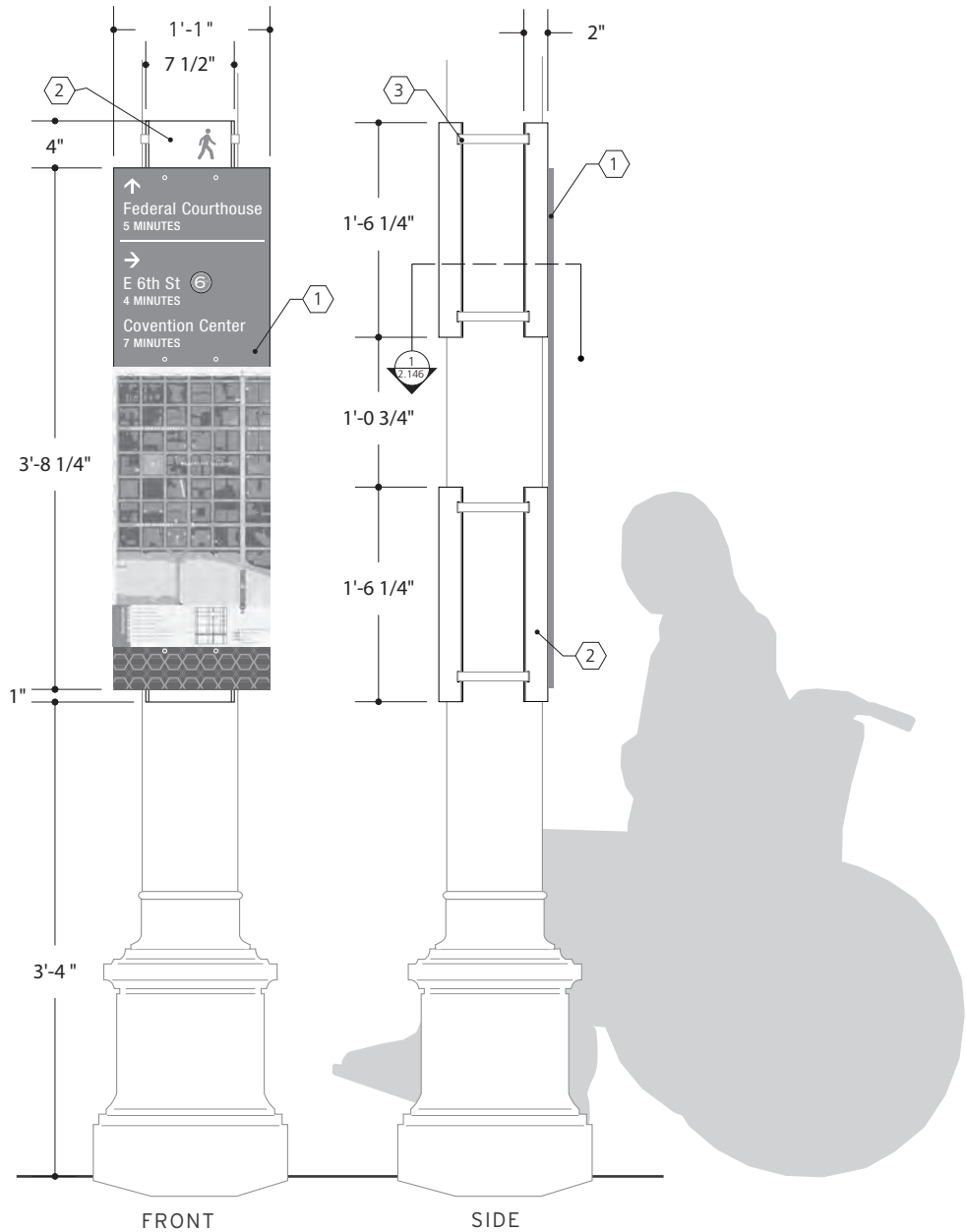

These drawings are meant for DESIGN INTENT ONLY and are not for construction. Contractor shall verify and be responsible for all dimensions and conditions of the job. Contractor shall be familiar with the site and conditions it presents. This office must be notified of any variations from the dimensions and conditions shown on this drawing. Shop drawings and details must be submitted to this office for approval prior to proceeding with fabrication. All copy shall be proofread by client and legal requirements checked by legal department.

1 Elevations PMAP.1
scale: 3/4"=1'-0"

- 1) 1/2" thick hi-resolution single-faced phenolic resin message panel
- 2) Sign structure assembled from brake-formed aluminum components (see PART C: Construction Details for more detail).
- 3) Sign is mounted on existing city light poles with adjustable 3/4" Band-fast with Color-It polyester coating to match existing light post finish. Verify all location conditions.

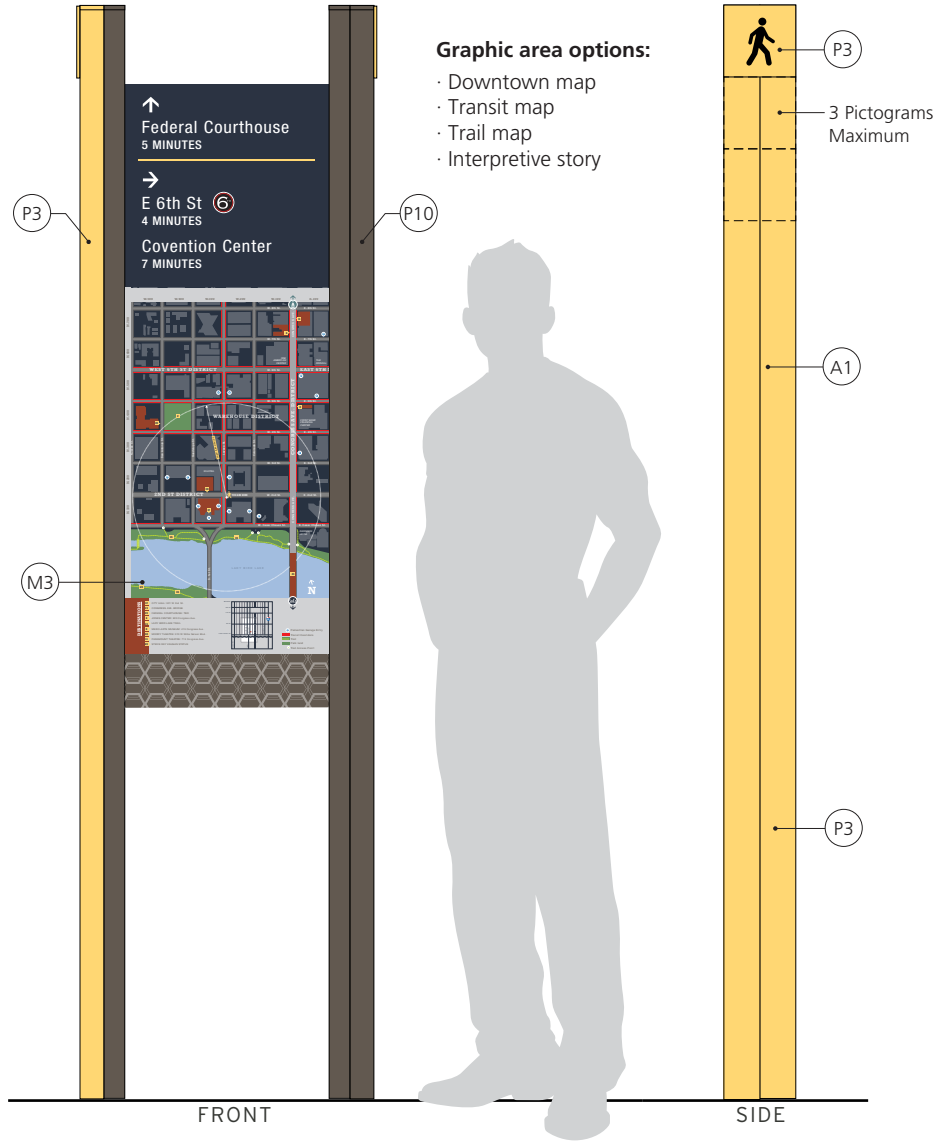

**PMAP.2
PEDESTRIAN MAP**

A series of pedestrian sign types have been developed to address various situations and communicate a variety of information.

MAPS:
In situations where orientation would assist a visitor, signs are available to display a map graphic. The "heads-up" map includes major landmarks and a 5 and 10 minute walk radius.

Signs can be mounted on existing posts or freestanding.

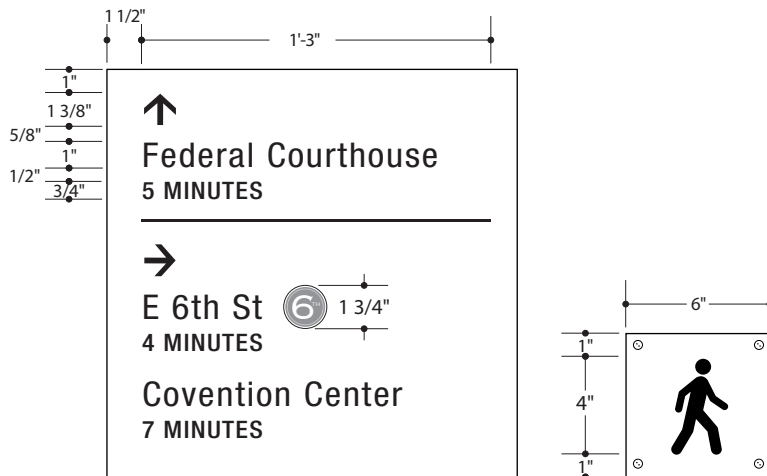

These drawings are meant for DESIGN INTENT ONLY and are not for construction. Contractor shall verify and be responsible for all dimensions and conditions of the job. Contractor shall be familiar with the site and conditions it presents. This office must be notified of any variations from the dimensions and conditions shown on this drawing. Shop drawings and details must be submitted to the City of Austin for approval prior to proceeding with fabrication. All copy shall be proofread by the City of Austin and legal requirements checked by legal department.

PMAP.2
PEDESTRIAN MAP

All exposed surfaces shall have a anti-graffiti protectant. Painted surfaces will have a clear coating and vinyl surfaces shall have a clear vinyl over-lam as required by the paint and vinyl manufacturer.

All exposed fasteners shall be painted to match adjacent surface.

All sign structures shall be signed and sealed by a certified Texas structural engineer prior to fabrication.

Contractor shall be familiar with all mounting and field conditions including; pole size, obstructions, mounting heights, structural integrity and all other conditions that may affect the fabrication, installation and long-term lifespan of the sign, bracket and other components.

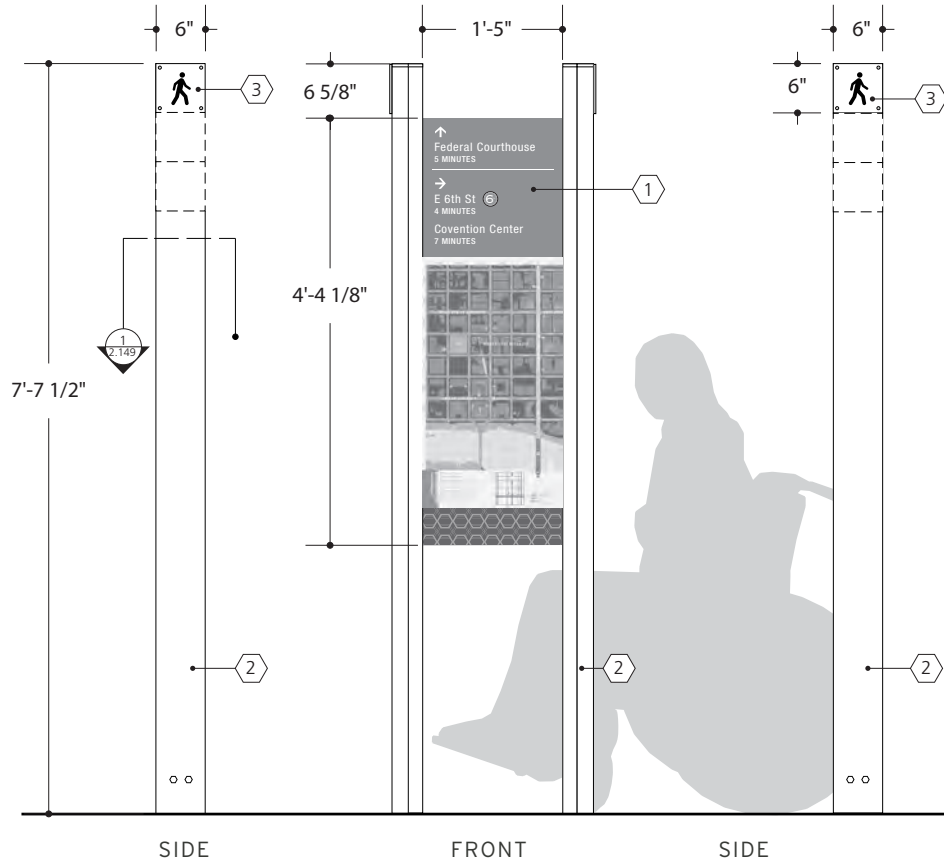
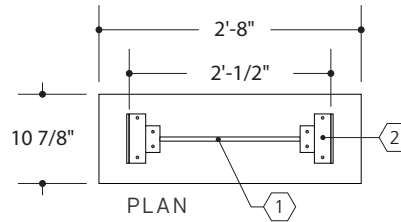

1 Elevations PMAP.2
scale: 1/2"=1'-0"

These drawings are meant for DESIGN INTENT ONLY and are not for construction. Contractor shall verify and be responsible for all dimensions and conditions of the job. Contractor shall be familiar with the site and conditions it presents. This office must be notified of any variations from the dimensions and conditions shown on this drawing. Shop drawings and details must be submitted to this office for approval prior to proceeding with fabrication. All copy shall be proofread by client and legal requirements checked by legal department.

- 1 1/2" phenolic resin double-sided message panel set in panel adapter extrusion.
- 2 Aluminum extrusion frame assembly.
- 3 1/4" alum painted sign panel mechanically fastened to frame assembly.

NOTE: See PART C: Construction Details for more fabrication details.

**PKIOSK.1
PEDESTRIAN KIOSK**

A series of pedestrian sign types have been developed to address various situations and communicate a variety of information.

KIOSKS:
Located at key gathering points, kiosks provide even broader information and are substantial, offering directions, maps and in some cases technology access.

These signs can be internally illuminated, have architectural bases, and those with canopies can utilize solar power.

Kiosks located in the Downtown have Texas Limestone bases.

Pictograms correspond with the panel information shown. Three (3) Pictograms per sign-per side.

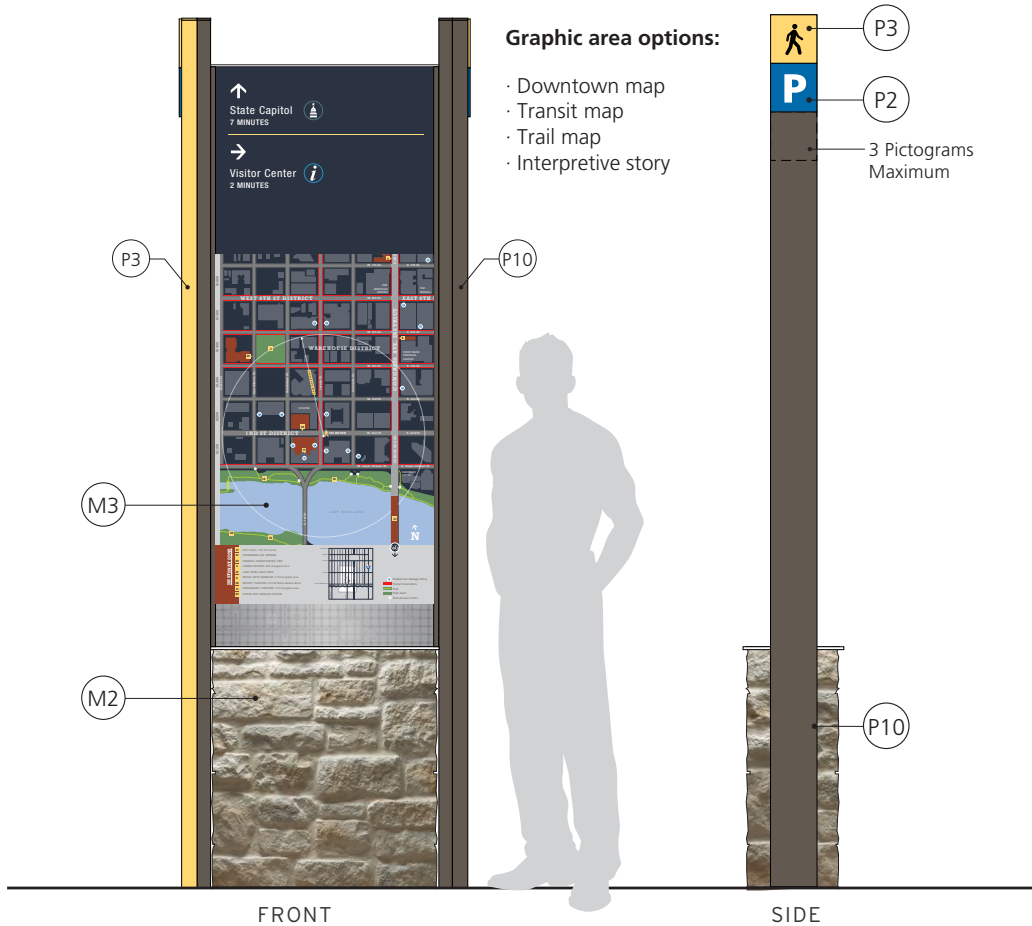

1 Color Schedule - PKIOSK.1
scale: 1/2"=1'-0"

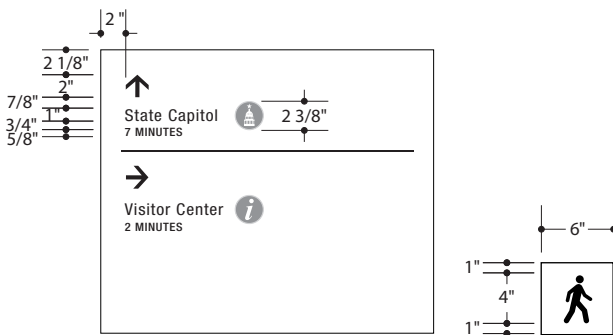

2 Typical Layout Guidelines - PKIOSK.1
scale: 3/4"=1'-0"

These drawings are meant for DESIGN INTENT ONLY and are not for construction. Contractor shall verify and be responsible for all dimensions and conditions of the job. Contractor shall be familiar with the site and conditions it presents. This office must be notified of any variations from the dimensions and conditions shown on this drawing. Shop drawings and details must be submitted to the City of Austin for approval prior to proceeding with fabrication. All copy shall be proofread by the City of Austin and legal requirements checked by legal department.

PKIOSK.1
PEDESTRIAN KIOSK

All exposed surfaces shall have a anti-graffiti protectant. Painted surfaces will have a clear coating and vinyl surfaces shall have a clear vinyl over-lam as required by the paint and vinyl manufacturer.

All exposed fasteners shall be painted to match adjacent surface.

All sign structures shall be signed and sealed by a certified Texas structural engineer prior to fabrication.

Contractor shall be familiar with all mounting and field conditions including; pole size, obstructions, mounting heights, structural integrity and all other conditions that may affect the fabrication, installation and long-term lifespan of the sign, bracket and other components.

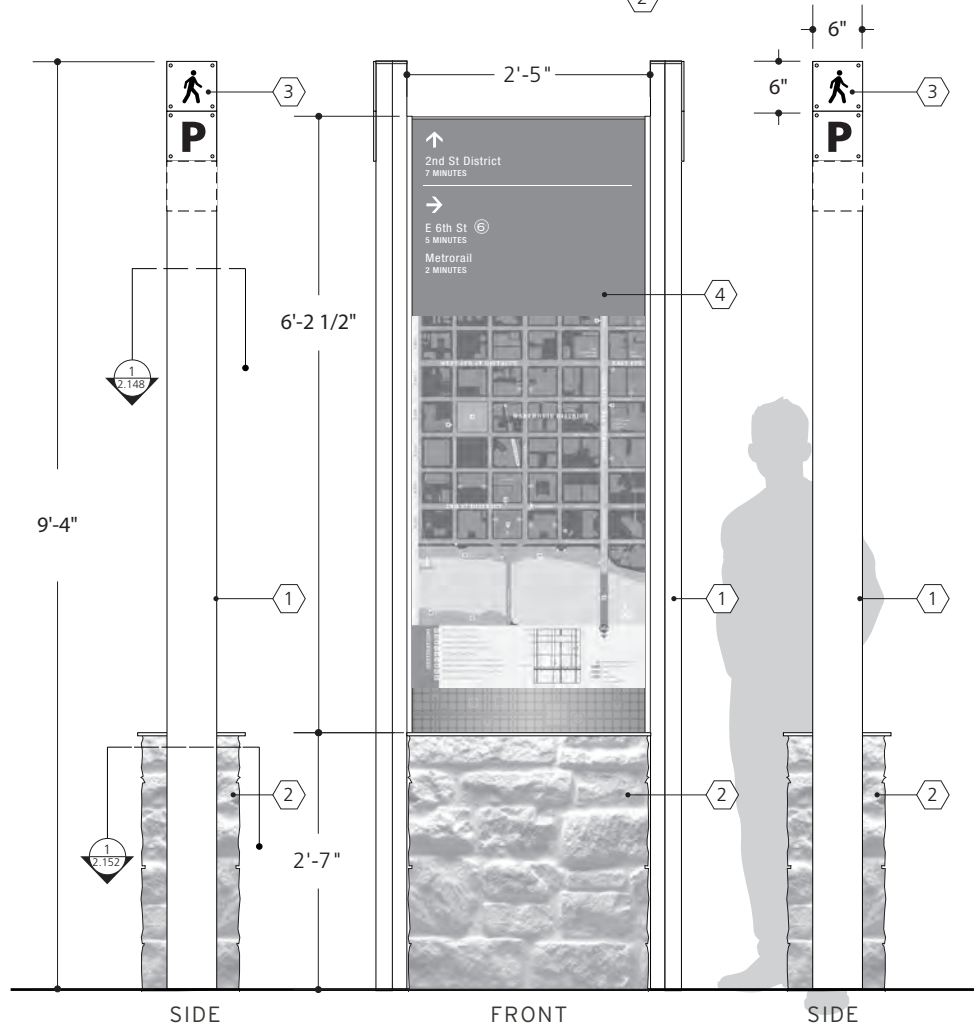
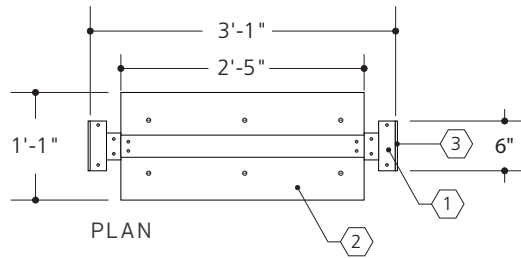

These drawings are meant for DESIGN INTENT ONLY and are not for construction. Contractor shall verify and be responsible for all dimensions and conditions of the job. Contractor shall be familiar with the site and conditions it presents. This office must be notified of any variations from the dimensions and conditions shown on this drawing. Shop drawings and details must be submitted to this office for approval prior to proceeding with fabrication. All copy shall be proofread by client and legal requirements checked by legal department.

1 Elevations PKIOSK.1
scale: 1/2"=1'-0"

- 1** Aluminum extrusion frame assembly
- 2** Texas Limestone cultured stone base assembly
- 3** 1/4" alum painted sign panel mechanically fastened to frame assembly
- 4** Phenolic resin panels into slide-body extrusion frame

NOTES: See PART C: Construction Details for more fabrication details.

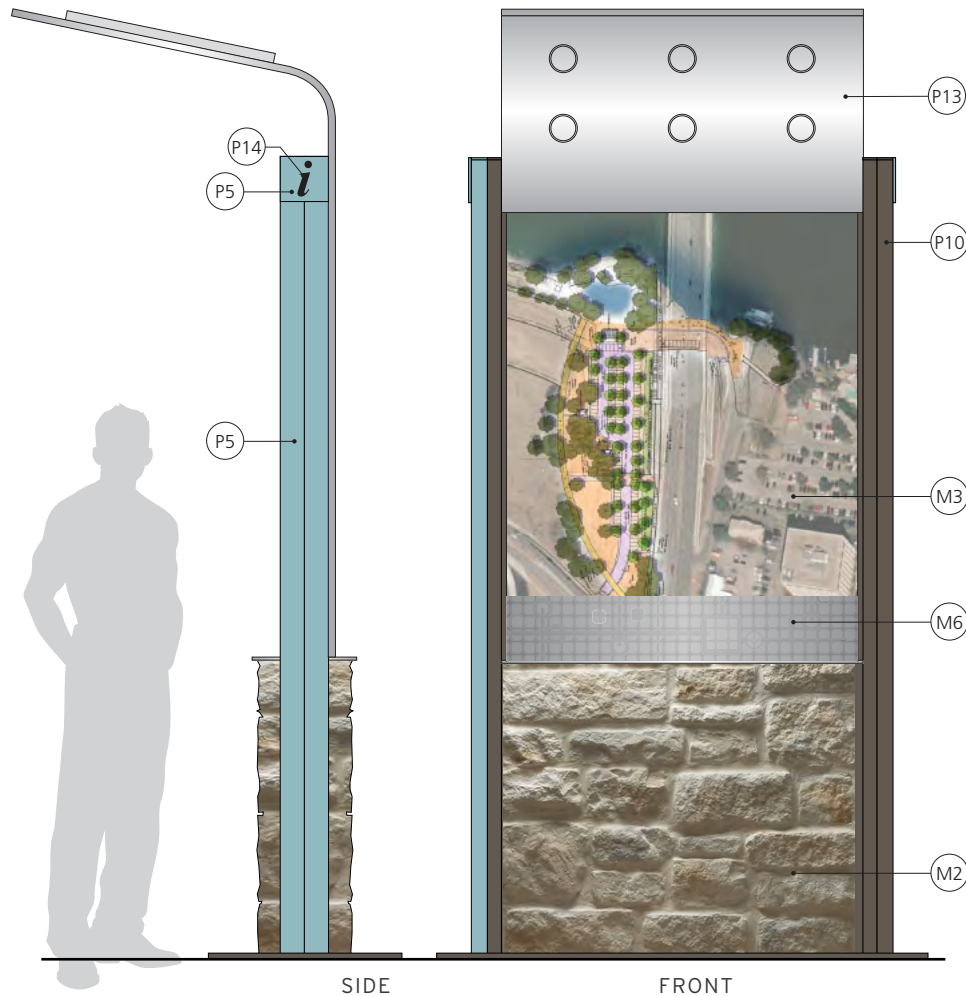

**PKIOSK.2
PEDESTRIAN KIOSK**

A series of pedestrian sign types have been developed to address various situations and communicate a variety of information.

STATIC INFO KIOSKS:
Located at key gathering points, kiosks provide even broader information and are substantial, offering directions and maps.

These single-sided signs are internally illuminated, have architectural bases and can utilize solar power. The information presented is a single panel with-in a frame assembly.

Kiosks located in the Downtown have Texas Limestone bases.

Pictograms correspond with the panel information shown. Three (3) Pictograms per sign-per side.

1 **Color Schedule - PKIOSK.2**
scale: 1/2"=1'-0"

These drawings are meant for DESIGN INTENT ONLY and are not for construction. Contractor shall verify and be responsible for all dimensions and conditions of the job. Contractor shall be familiar with the site and conditions it presents. This office must be notified of any variations from the dimensions and conditions shown on this drawing. Shop drawings and details must be submitted to the City of Austin for approval prior to proceeding with fabrication. All copy shall be proofread by the City of Austin and legal requirements checked by legal department.

PKIOSK.2
PEDESTRIAN KIOSK

All exposed surfaces shall have an anti-graffiti protectant. Painted surfaces will have a clear coating and vinyl surfaces shall have a clear vinyl over-lam as required by the paint and vinyl manufacturer.

All exposed fasteners shall be painted to match adjacent surface.

All sign structures shall be signed and sealed by a certified Texas structural engineer prior to fabrication.

Contractor shall be familiar with all mounting and field conditions including; pole size, obstructions, mounting heights, structural integrity and all other conditions that may affect the fabrication, installation and long-term lifespan of the sign, bracket and other components.

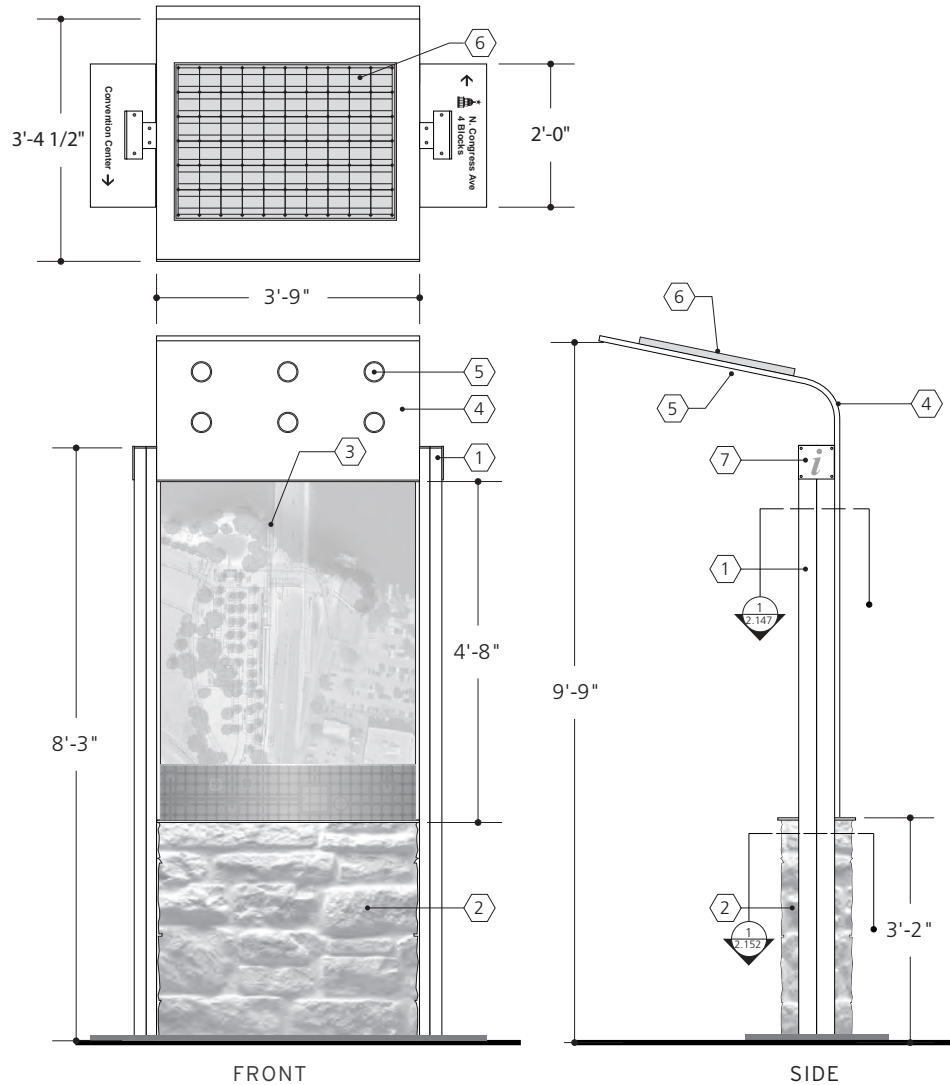

1 Elevations PKIOSK.2
scale: 3/8"=1'-0"

- ① Aluminum extrusion frame assembly
- ② Texas Limestone cultured stone base assembly
- ③ 1/8" alum message panels mounted into slide body extrusion
- ④ Alum canopy assembly mechanically fastened to frame assembly
- ⑤ LED light fixtures - Cree LMR2 recessed in canopy underside
- ⑥ Solar panel mounted to canopy top
- ⑦ 1/4" alum painted sign panel mechanically fastened to frame assembly

NOTES: See PART C: Construction Details for more fabrication detail.

These drawings are meant for DESIGN INTENT ONLY and are not for construction. Contractor shall verify and be responsible for all dimensions and conditions of the job. Contractor shall be familiar with the site and conditions it presents. This office must be notified of any variations from the dimensions and conditions shown on this drawing. Shop drawings and details must be submitted to this office for approval prior to proceeding with fabrication. All copy shall be proofread by client and legal requirements checked by legal department.

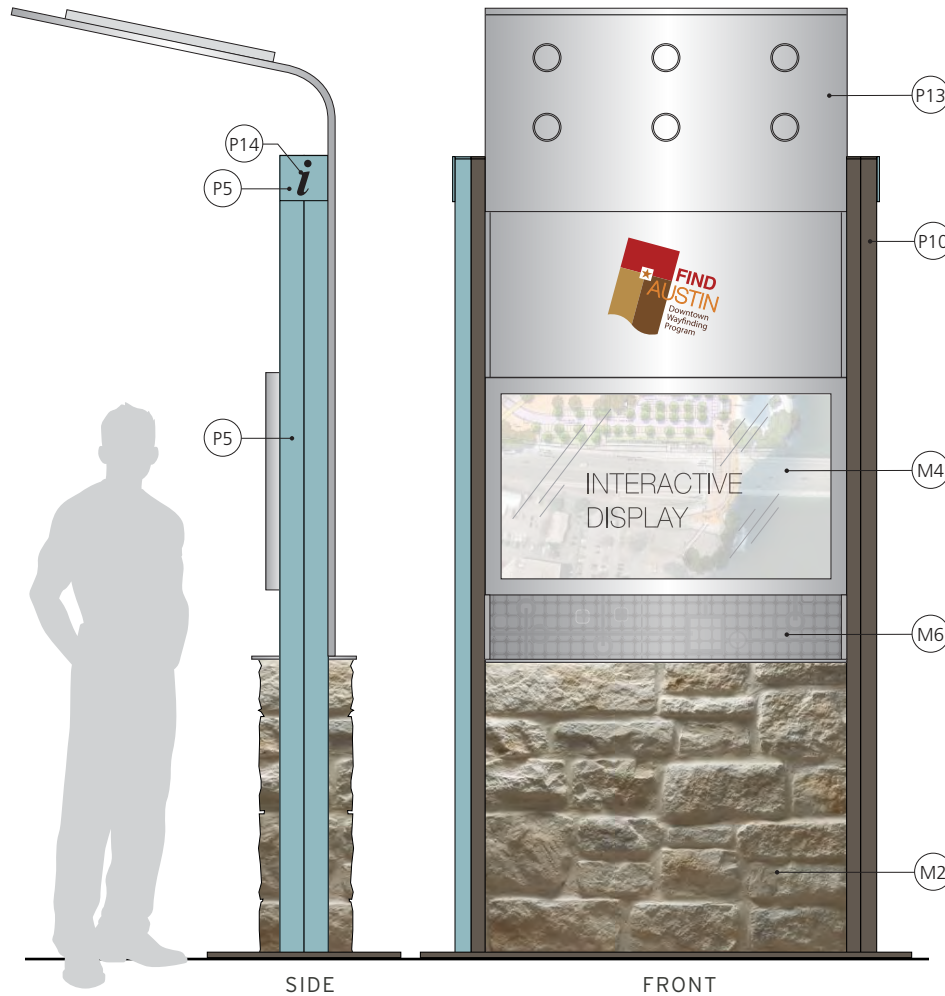

1 Color Schedule - PKIOSK.2a
scale: 1/2"=1'-0"

**PKIOSK.2A
PEDESTRIAN KIOSK**

A series of pedestrian sign types have been developed to address various situations and communicate a variety of information.

DIGITAL INFO KIOSKS:
Located at key gathering points, kiosks provide even broader information and are substantial, offering directions and maps.

These single-sided signs are interactive, have architectural bases and can utilize solar power for the down-lights. The information has a digital or interactive element and is a wi-fi hotspot. QR Codes may link to CVB website or COA website.

The following info/data may be appear as part of technology components:

- City Maintained
 - PARKING
 - ATTRACTIONS
 - GOVERNMENT BUILDINGS
 - EVENTS
 - PUBLIC TRANSIT / CAPMETRO
 - CONVENTION CENTER INFO
 - PARKS AND RECREATION
 - CONSTRUCTION UPDATES
- CVB Maintained
 - ACCOMMODATIONS
 - SHOPPING
 - DINING

Kiosks located in the Downtown have Texas Limestone bases.

Pictograms correspond with the panel information shown. Three (3) Pictograms per sign-per side.

These drawings are meant for DESIGN INTENT ONLY and are not for construction. Contractor shall verify and be responsible for all dimensions and conditions of the job. Contractor shall be familiar with the site and conditions it presents. This office must be notified of any variations from the dimensions and conditions shown on this drawing. Shop drawings and details must be submitted to the City of Austin for approval prior to proceeding with fabrication. All copy shall be proofread by the City of Austin and legal requirements checked by legal department.

PKIOSK.2A
PEDESTRIAN KIOSK

All exposed surfaces shall have an anti-graffiti protectant. Painted surfaces will have a clear coating and vinyl surfaces shall have a clear vinyl over-lam as required by the paint and vinyl manufacturer.

All exposed fasteners shall be painted to match adjacent surface.

All sign structures shall be signed and sealed by a certified Texas structural engineer prior to fabrication.

Contractor shall be familiar with all mounting and field conditions including; pole size, obstructions, mounting heights, structural integrity and all other conditions that may affect the fabrication, installation and long-term lifespan of the sign, bracket and other components.

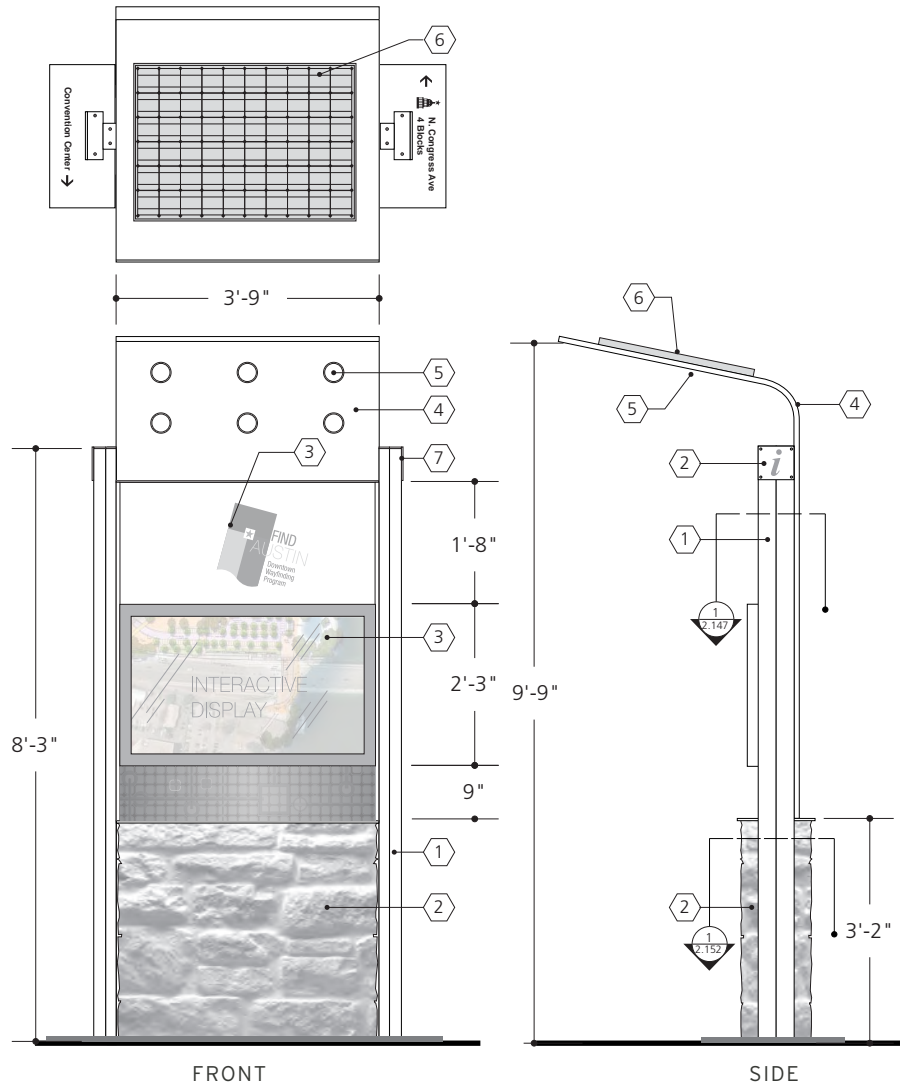

1 Elevations PKIOSK.2a
scale: 3/8"=1'-0"

- ① Aluminum extrusion frame assembly
- ② Texas Limestone cultured stone base assembly
- ③ Interactive touchscreen with technology hub
- ④ Alum canopy assembly mechanically fastened to frame assembly
- ⑤ LED light fixtures - Cree LMR2 recessed in canopy underside
- ⑥ Solar panel mounted to canopy top
- ⑦ 1/4" alum painted sign panel mechanically fastened to frame assembly

NOTES: See PART C: Construction Details for more fabrication detail.

These drawings are meant for DESIGN INTENT ONLY and are not for construction. Contractor shall verify and be responsible for all dimensions and conditions of the job. Contractor shall be familiar with the site and conditions it presents. This office must be notified of any variations from the dimensions and conditions shown on this drawing. Shop drawings and details must be submitted to this office for approval prior to proceeding with fabrication. All copy shall be proofread by client and legal requirements checked by legal department.

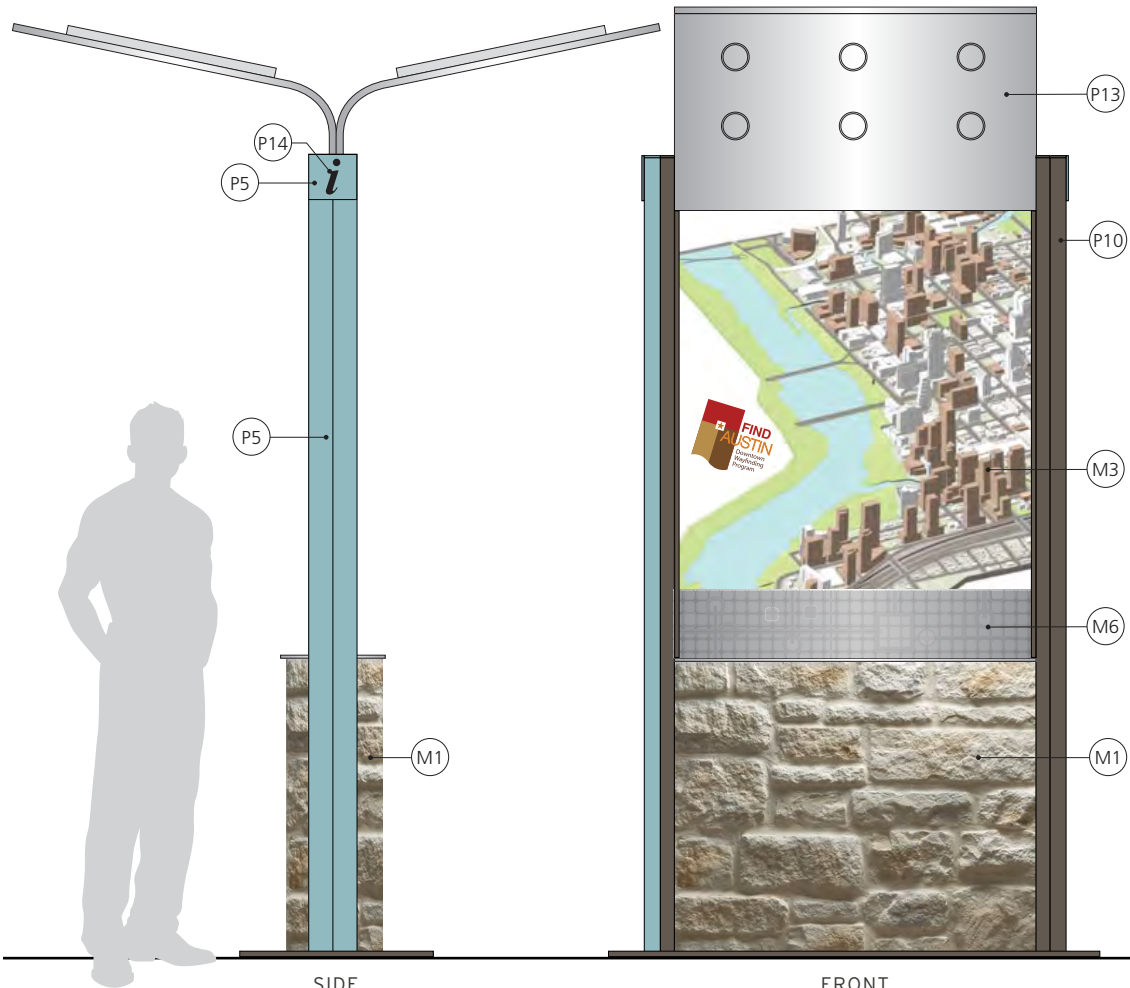

**PKIOSK.3
PEDESTRIAN KIOSK**

A series of pedestrian sign types have been developed to address various situations and communicate a variety of information.

STATIC INFO KIOSKS:
Located at key gathering points, kiosks provide even broader information and are substantial, offering directions and maps.

These double-sided signs are internally illuminated, have architectural bases and can utilize solar power. The information presented are two (2) single panels with-in a frame assembly.

Kiosks located in the Downtown have Texas Limestone bases.

Pictograms correspond with the panel information shown. Three (3) Pictograms per sign-per side.

SIDE FRONT
1 Color Schedule - PKIOSK.3a
 scale: 1/2"=1'-0"

These drawings are meant for DESIGN INTENT ONLY and are not for construction. Contractor shall verify and be responsible for all dimensions and conditions of the job. Contractor shall be familiar with the site and conditions it presents. This office must be notified of any variations from the dimensions and conditions shown on this drawing. Shop drawings and details must be submitted to the City of Austin for approval prior to proceeding with fabrication. All copy shall be proofread by the City of Austin and legal requirements checked by legal department.

**PKIOSK.3
PEDESTRIAN KIOSK**

All exposed surfaces shall have an anti-graffiti protectant. Painted surfaces will have a clear coating and vinyl surfaces shall have a clear vinyl over-lam as required by the paint and vinyl manufacturer.

All exposed fasteners shall be painted to match adjacent surface.

All sign structures shall be signed and sealed by a certified Texas structural engineer prior to fabrication.

Contractor shall be familiar with all mounting and field conditions including; pole size, obstructions, mounting heights, structural integrity and all other conditions that may affect the fabrication, installation and long-term lifespan of the sign, bracket and other components.

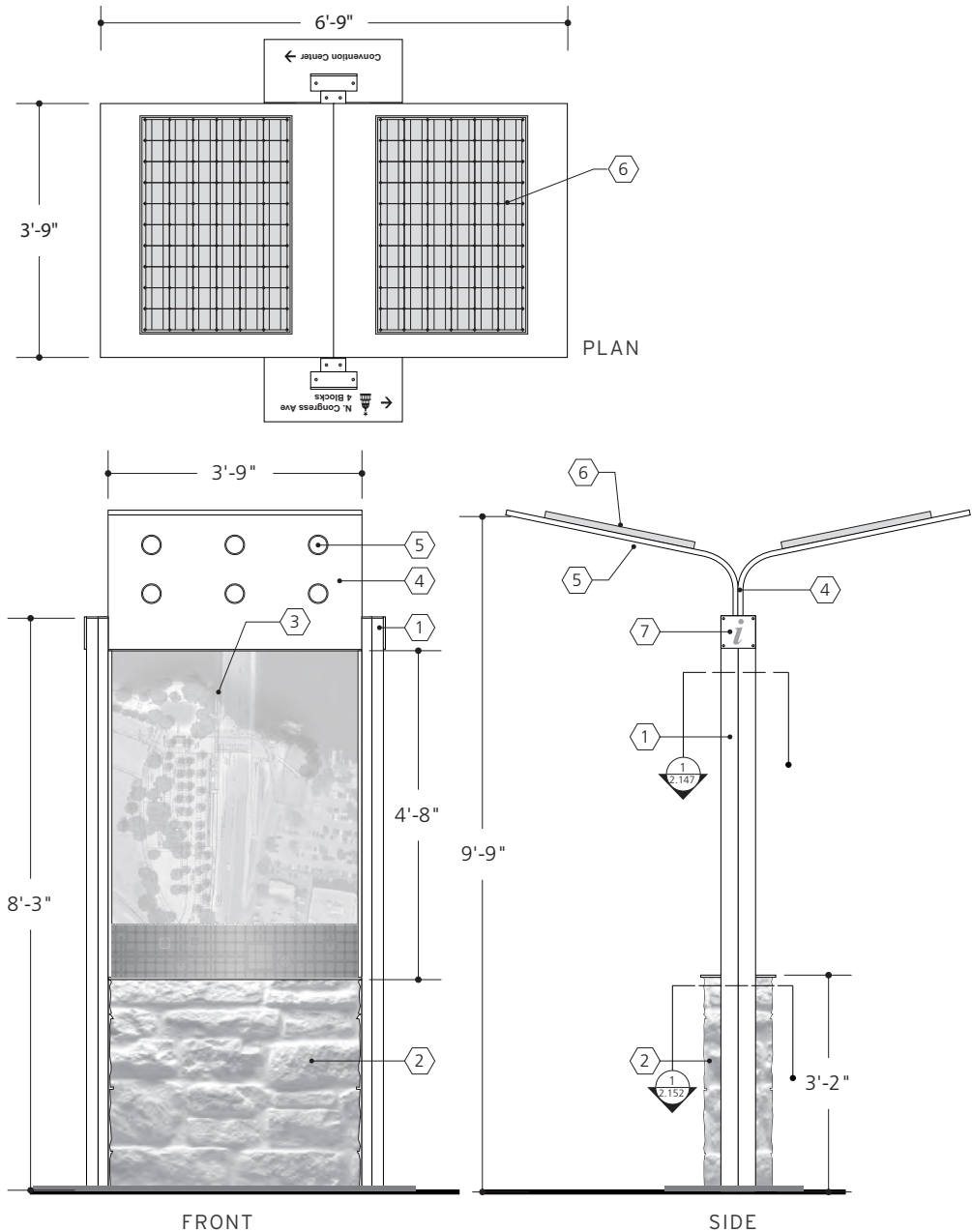

1 Elevations PKIOSK.3
scale: 3/8"=1'-0"

These drawings are meant for DESIGN INTENT ONLY and are not for construction. Contractor shall verify and be responsible for all dimensions and conditions of the job. Contractor shall be familiar with the site and conditions it presents. This office must be notified of any variations from the dimensions and conditions shown on this drawing. Shop drawings and details must be submitted to this office for approval prior to proceeding with fabrication. All copy shall be proofread by client and legal requirements checked by legal department.

- ① Aluminum extrusion frame assembly
- ② Texas Limestone cultured stone base assembly
- ③ Alum or phenolic resin panel into slide-body extrusion frame
- ④ Alum canopy assembly mechanically fastened to frame assembly
- ⑤ LED light fixtures - Cree LMR2 recessed in canopy underside

- ⑥ Solar panel mounted to canopy top
- ⑦ 1/4" alum painted sign panel mechanically fastened to frame assembly

NOTES: See PART C: Construction Details for more fabrication detail.

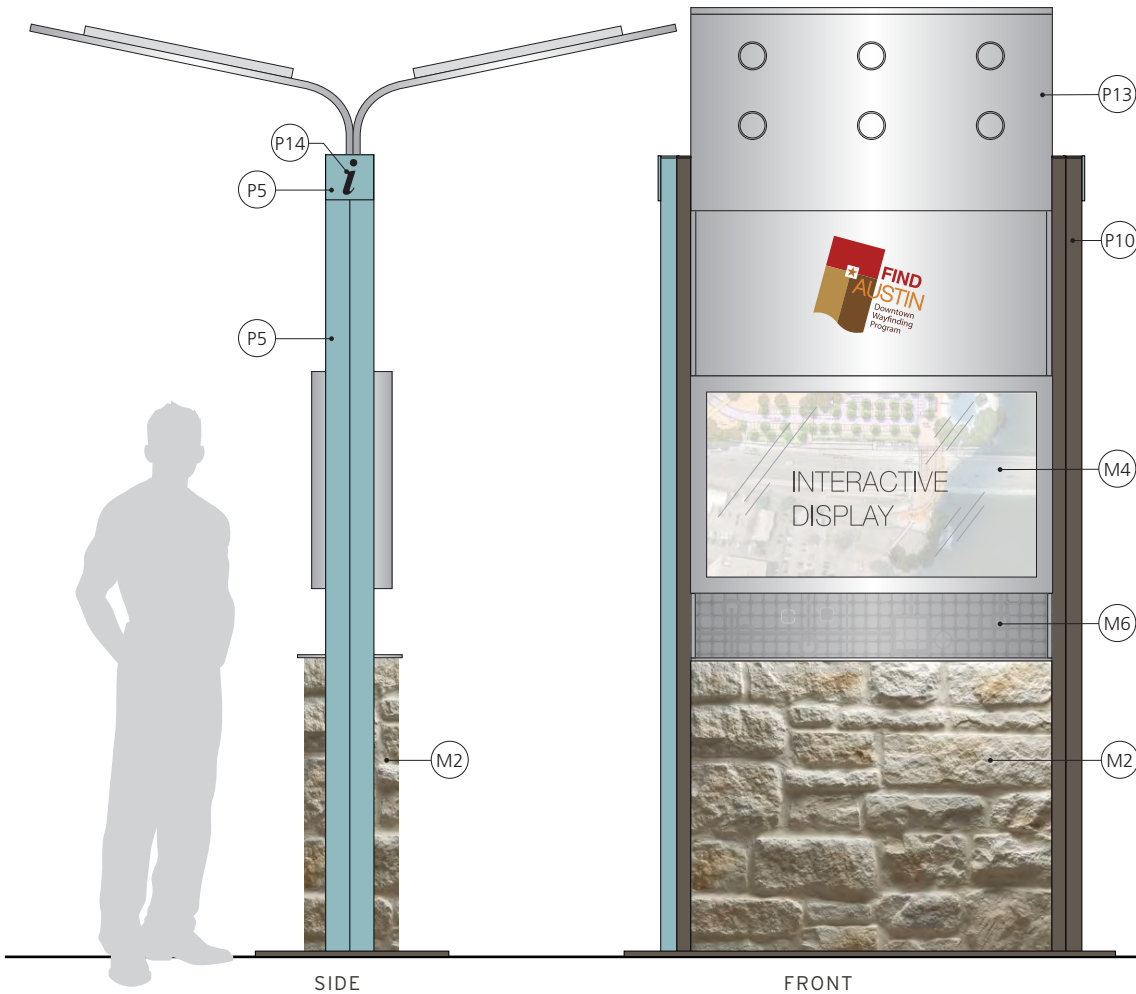

1 Color Schedule - PKIOSK.3a
scale: 1/2"=1'-0"

**PKIOSK.3A
PEDESTRIAN KIOSK**

A series of pedestrian sign types have been developed to address various situations and communicate a variety of information.

DIGITAL INFO KIOSKS:
Located at key gathering points, kiosks provide even broader information and are substantial, offering directions and maps.

These double-sided signs are interactive, have architectural bases and can utilize solar power for the down-lights. The information has a digital or interactive element and is a wi-fi hotspot. QR Codes may link to CVB website or COA website.

The following info/data may be appear as part of technology components:

- City Maintained
- PARKING
 - ATTRACTIONS
 - GOVERNMENT BUILDINGS
 - EVENTS
 - PUBLIC TRANSIT / CAPMETRO
 - CONVENTION CENTER INFO
 - PARKS AND RECREATION
 - CONSTRUCTION UPDATES

- CVB Maintained
- ACCOMMODATIONS
 - SHOPPING
 - DINING

Kiosks located in the Downtown have Texas Limestone bases.

Pictograms correspond with the panel information shown. Three (3) Pictograms per sign-per side.

These drawings are meant for DESIGN INTENT ONLY and are not for construction. Contractor shall verify and be responsible for all dimensions and conditions of the job. Contractor shall be familiar with the site and conditions it presents. This office must be notified of any variations from the dimensions and conditions shown on this drawing. Shop drawings and details must be submitted to the City of Austin for approval prior to proceeding with fabrication. All copy shall be proofread by the City of Austin and legal requirements checked by legal department.

PKIOSK.3A
PEDESTRIAN KIOSK

All exposed surfaces shall have an anti-graffiti protectant. Painted surfaces will have a clear coating and vinyl surfaces shall have a clear vinyl over-lam as required by the paint and vinyl manufacturer.

All exposed fasteners shall be painted to match adjacent surface.

All sign structures shall be signed and sealed by a certified Texas structural engineer prior to fabrication.

Contractor shall be familiar with all mounting and field conditions including; pole size, obstructions, mounting heights, structural integrity and all other conditions that may affect the fabrication, installation and long-term lifespan of the sign, bracket and other components.

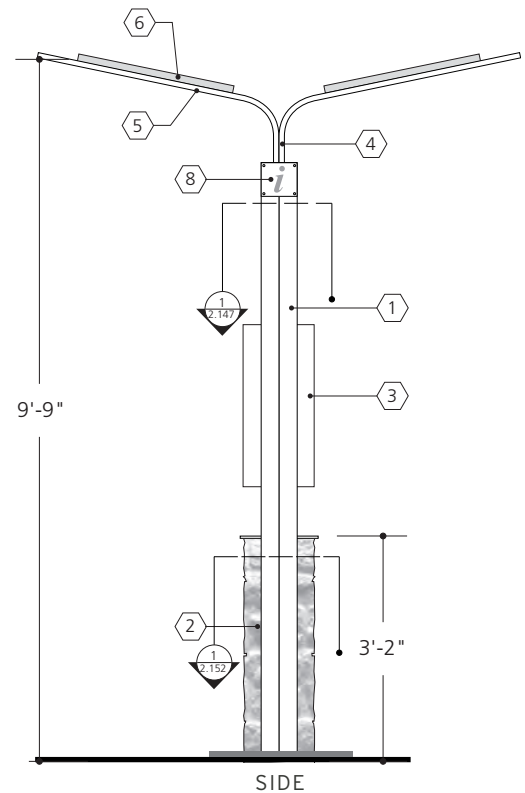
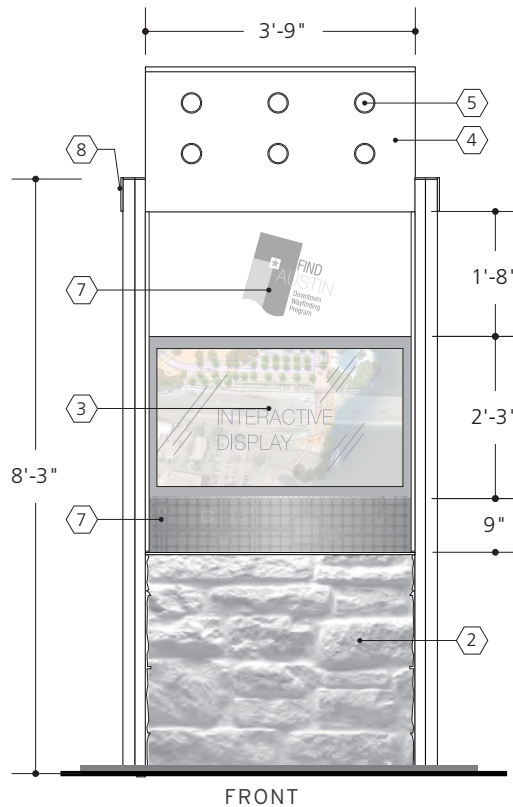
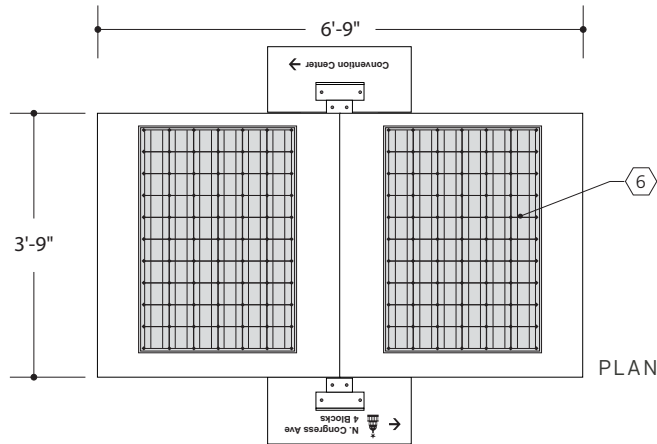

1 Elevations PKIOSK.3a
scale: 3/8"=1'-0"

These drawings are meant for DESIGN INTENT ONLY and are not for construction. Contractor shall verify and be responsible for all dimensions and conditions of the job. Contractor shall be familiar with the site and conditions it presents. This office must be notified of any variations from the dimensions and conditions shown on this drawing. Shop drawings and details must be submitted to this office for approval prior to proceeding with fabrication. All copy shall be proofread by client and legal requirements checked by legal department.

- 1 Aluminum extrusion frame assembly
- 2 Texas Limestone cultured stone base assembly
- 3 Interactive HD display. Casing mounted to slide body extrusion with reinforcement frame
- 4 Alum canopy assembly mechanically fastened to frame assembly
- 5 LED light fixtures - Cree LMR2 recessed in canopy underside

- 6 Solar panel mounted to canopy top
- 7 1/4" alum message panels mounted into slide body extrusion
- 8 1/4" alum painted sign panels mechanically fastened to frame assembly

NOTES: See PART C: Construction Details for more fabrication detail.

PDIR.7
PEDESTRIAN KIOSK
DIRECTIONAL PLAQUE

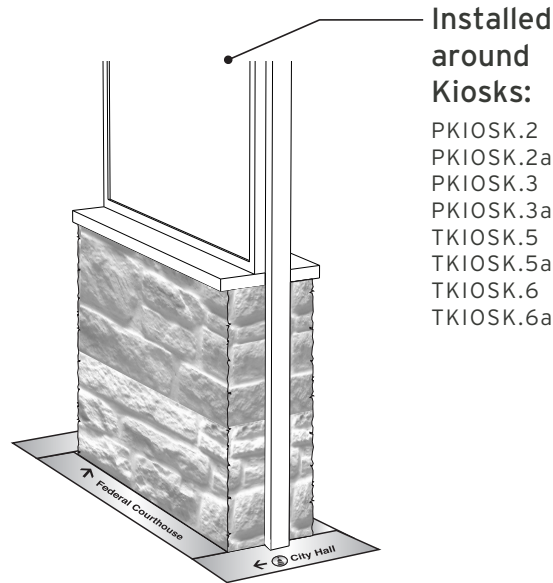

1 Rendering: PDIR.7
 nts

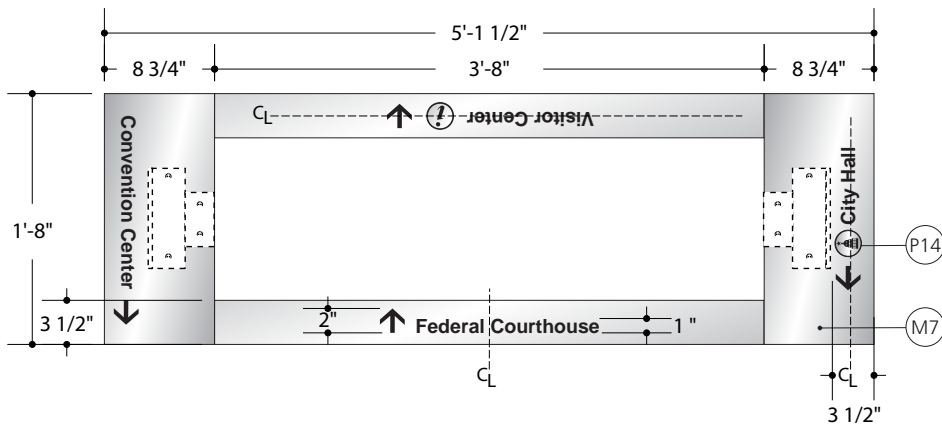

2 Graphic Layout: PDIR.7
 scale: 3/4"=1'-0"

These drawings are meant for DESIGN INTENT ONLY and are not for construction. Contractor shall verify and be responsible for all dimensions and conditions of the job. Contractor shall be familiar with the site and conditions it presents. This office must be notified of any variations from the dimensions and conditions shown on this drawing. Shop drawings and details must be submitted to the City of Austin for approval prior to proceeding with fabrication. All copy shall be proofread by the City of Austin and legal requirements checked by legal department.

PART C:
Construction Details

DEFAULT DECORATIVE PATTERNS/MATERIALS
MAP, KIOSK & DIST, & TRAIL SIGN TYPES

ARTISTIC PANELS:
 At the right are the provided artistic panels for DIST, PDIR and KIOSK signs.

Artistic Panels

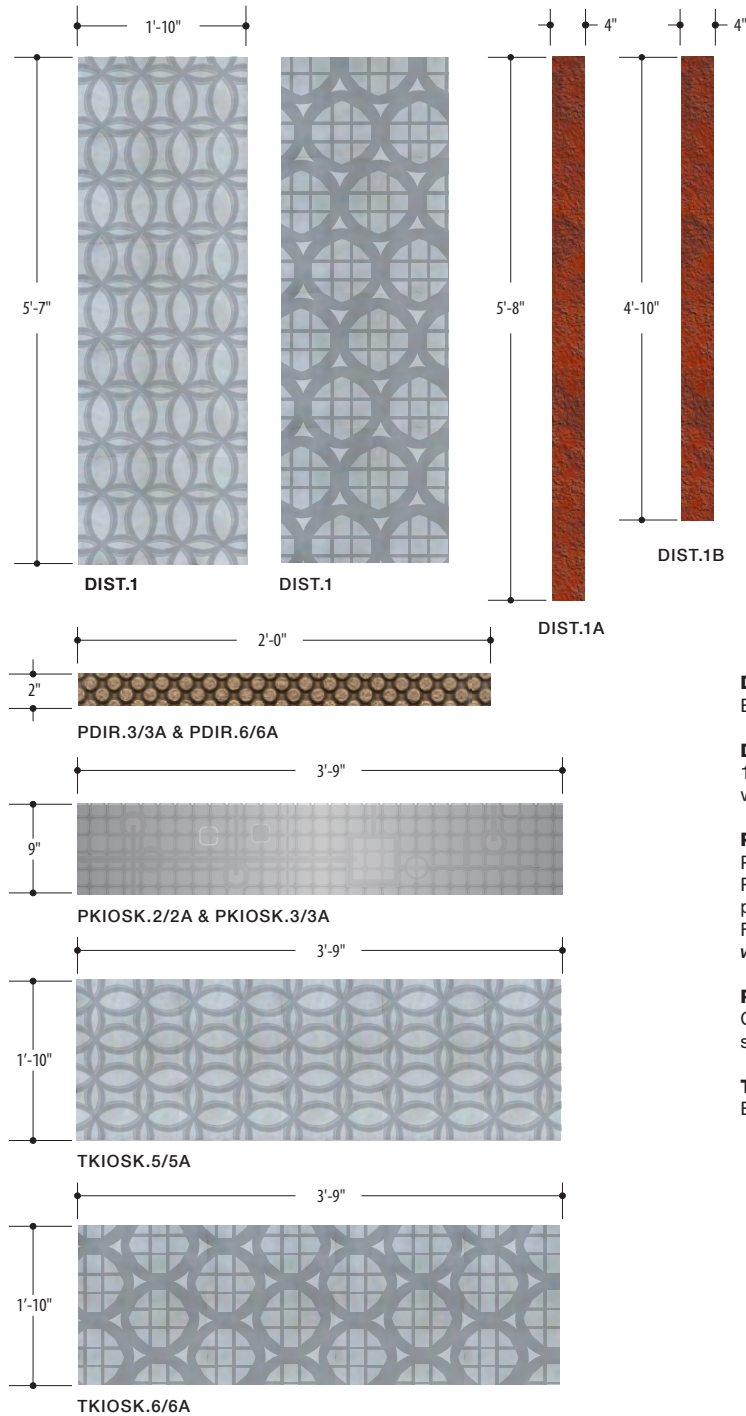

DIST.1:
 Bas relief pattern in cast concrete.

DIST.1A/1B:
 1/8" thick rusted red metal material, with clear-coat finish.

PDIR.3/3A & PDIR.6/6A:
 Product:
 Rigidized Metals textured copper panel. Pattern: 6HC (.0120" thk.)
 Fastened mechanically to i-Zone panel.
www.rigidized.com

PKIOSK.2/2A & PKIOSK.2/2A:
 Chemically etched pattern in aluminum sheet, with clear-coat finish.

TKIOSK.5/5A & TKIOSK.6/6A:
 Bas relief pattern in cast concrete.

These drawings are meant for DESIGN INTENT ONLY and are not for construction. Contractor shall verify and be responsible for all dimensions and conditions of the job. Contractor shall be familiar with the site and conditions it presents. This office must be notified of any variations from the dimensions and conditions shown on this drawing. Shop drawings and details must be submitted to this office for approval prior to proceeding with fabrication. All copy shall be proofread by client and legal requirements checked by legal department.

Finials

**FINIAL DETAILS
VDIR, PARK &
DEST SIGNS**

FINIALS:
At the right is the provided finial design for VDIR, PARK and DEST signs.

NOTE:
See page 2.145 for Post Cap Section Details.

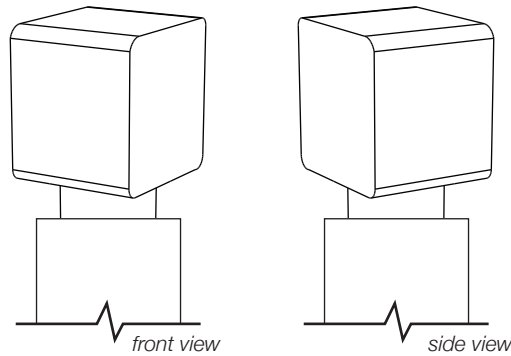

FINIAL:
Rounded corner aluminum cube, turned 45°

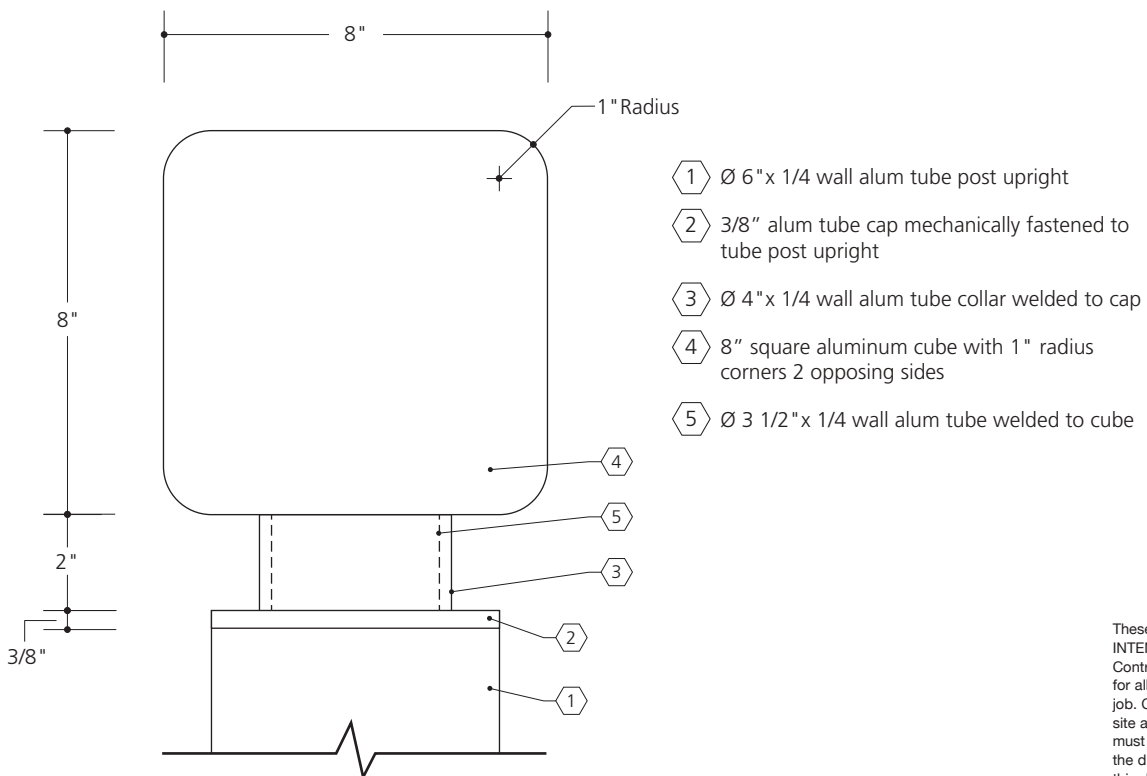

1 Elevation detail - cube post cap
Scale: 3" = 1' - 0"

These drawings are meant for DESIGN INTENT ONLY and are not for construction. Contractor shall verify and be responsible for all dimensions and conditions of the job. Contractor shall be familiar with the site and conditions it presents. This office must be notified of any variations from the dimensions and conditions shown on this drawing. Shop drawings and details must be submitted to the City of Austin for approval prior to proceeding with fabrication. All copy shall be proofread by the City of Austin and legal requirements checked by legal department.

SECTION DETAILS
VDIR & PARK
SIGNS

Modular details of system used for changeable panel signs

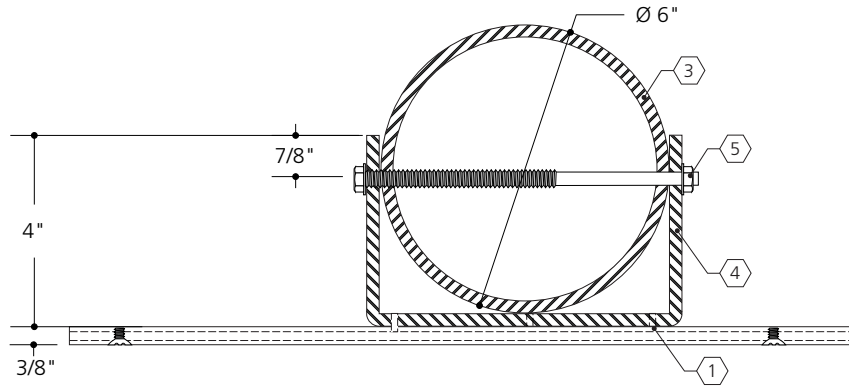

1 Section Detail
scale: 3"=1'-0"

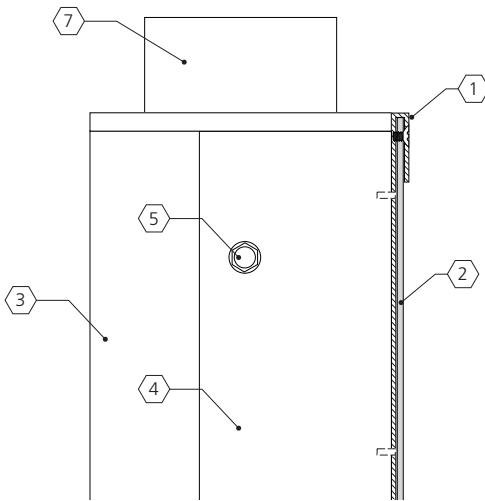

2 Detail
scale: 3"=1'-0"

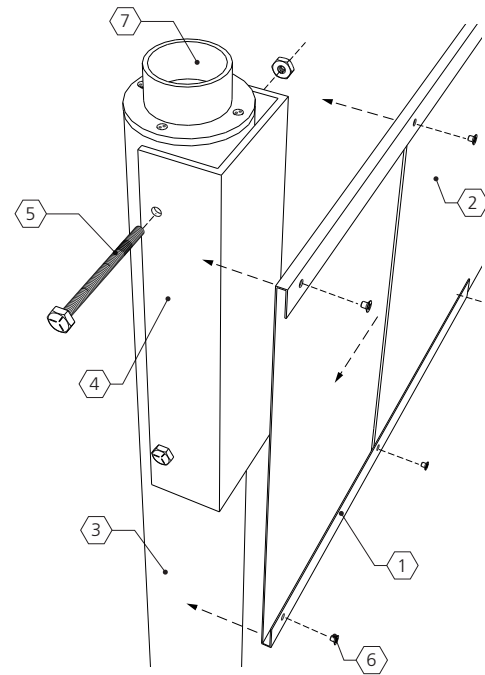

3 Exploded view
n t s

These drawings are meant for DESIGN INTENT ONLY and are not for construction. Contractor shall verify and be responsible for all dimensions and conditions of the job. Contractor shall be familiar with the site and conditions it presents. This office must be notified of any variations from the dimensions and conditions shown on this drawing. Shop drawings and details must be submitted to this office for approval prior to proceeding with fabrication. All copy shall be proofread by client and legal requirements checked by legal department.

- 1 Custom aluminum extrusion bracket plug welded to pole cuff
- 2 1/8" alum message panel mechanically fastened to bracket
- 3 6" x 1/4 wall alum tube upright
- 4 1/4" brake-formed alum pole cuff
- 5 1/2" stainless steel through-bolt
- 6 Set screws
- 7 Post-cap assembly

**SECTION DETAILS
POST CAP**

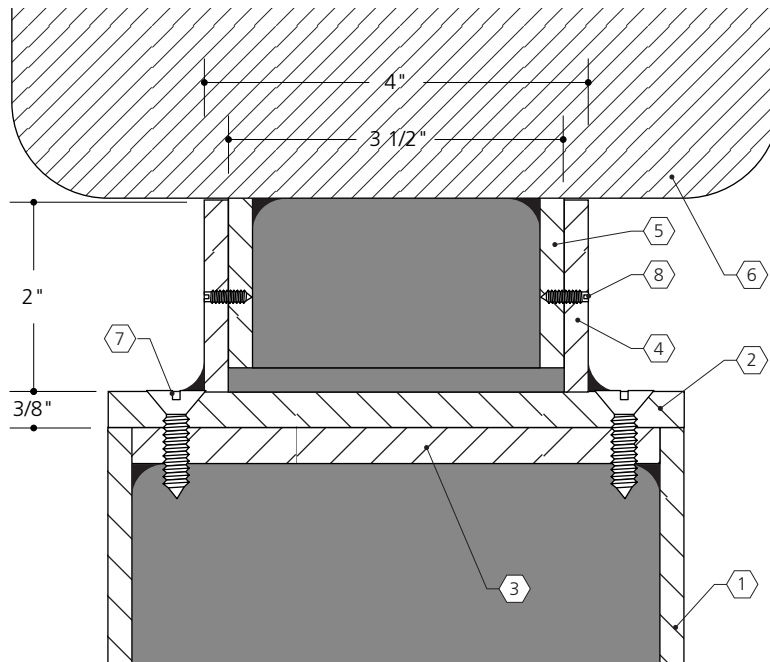

1 Section detail - post cap
half scale

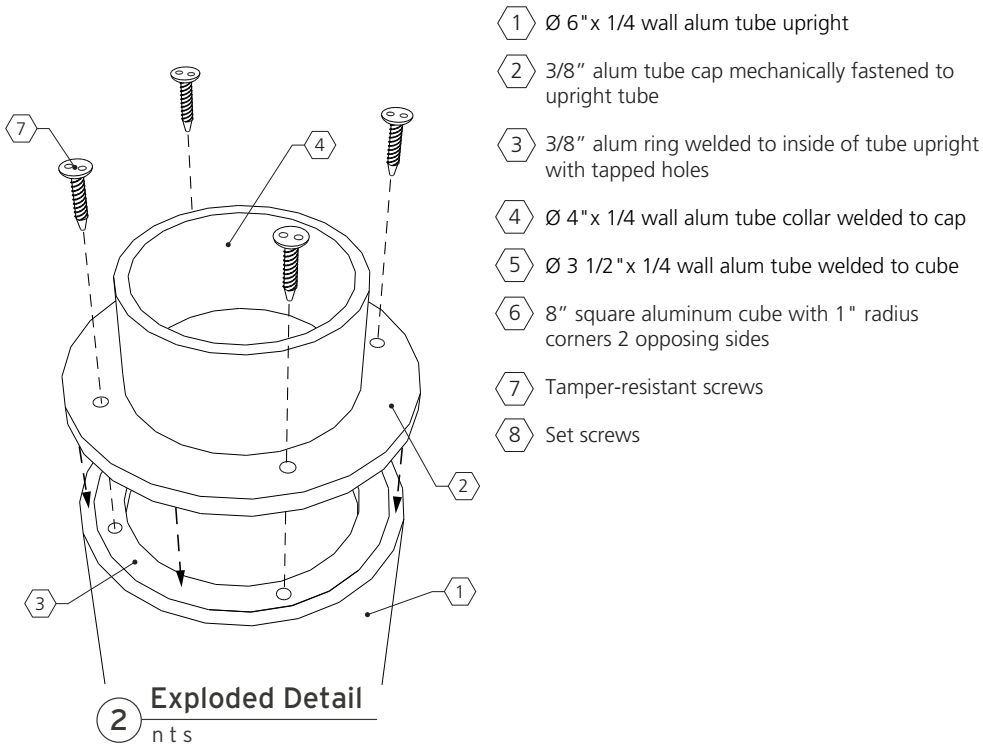

- 1 Ø 6" x 1/4 wall alum tube upright
- 2 3/8" alum tube cap mechanically fastened to upright tube
- 3 3/8" alum ring welded to inside of tube upright with tapped holes
- 4 Ø 4" x 1/4 wall alum tube collar welded to cap
- 5 Ø 3 1/2" x 1/4 wall alum tube welded to cube
- 6 8" square aluminum cube with 1" radius corners 2 opposing sides
- 7 Tamper-resistant screws
- 8 Set screws

These drawings are meant for DESIGN INTENT ONLY and are not for construction. Contractor shall verify and be responsible for all dimensions and conditions of the job. Contractor shall be familiar with the site and conditions it presents. This office must be notified of any variations from the dimensions and conditions shown on this drawing. Shop drawings and details must be submitted to the City of Austin for approval prior to proceeding with fabrication. All copy shall be proofread by the City of Austin and legal requirements checked by legal department.

SECTION DETAILS
PMAP.1
SIGNS

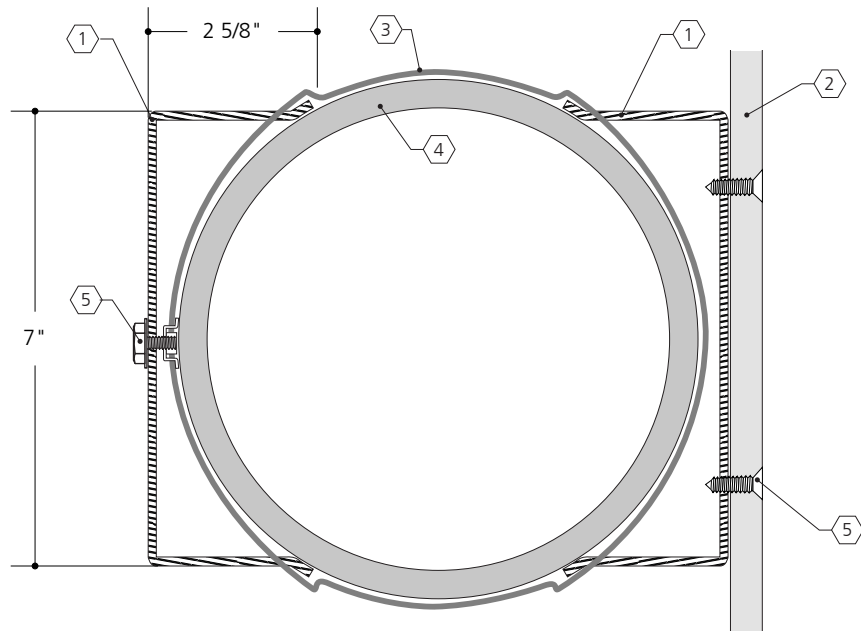

1 Section - PMAP.1
scale: 1:3

- 1** .090 brake-formed alum pole bracket with routed slots for banding - bolt to Band-fast nut
- 2** 1/2" phenolic resin panel - single-faced and mechanically fastened to pole bracket
- 3** 3/4" Band-fast with nut and Color-It polyester coating to match existing light post finish - verify all conditions in field.
- 4** Existing light post
- 5** Set screws

These drawings are meant for DESIGN INTENT ONLY and are not for construction. Contractor shall verify and be responsible for all dimensions and conditions of the job. Contractor shall be familiar with the site and conditions it presents. This office must be notified of any variations from the dimensions and conditions shown on this drawing. Shop drawings and details must be submitted to this office for approval prior to proceeding with fabrication. All copy shall be proofread by client and legal requirements checked by legal department.

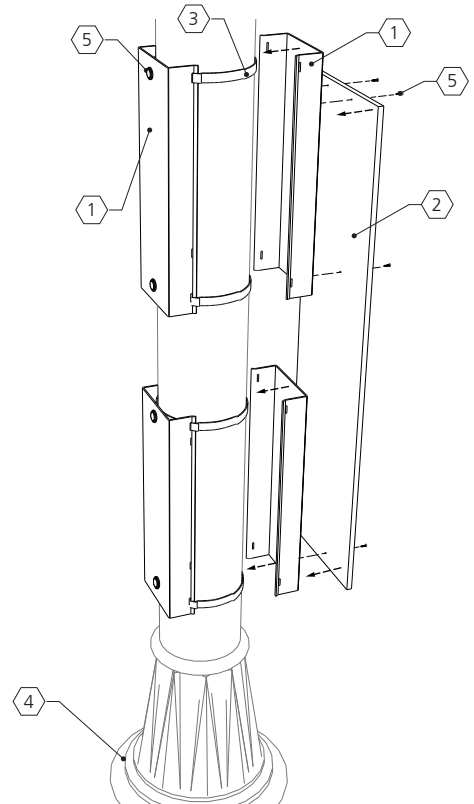

2 Exploded Detail
n t s

SECTION DETAILS
POST SECTION 1

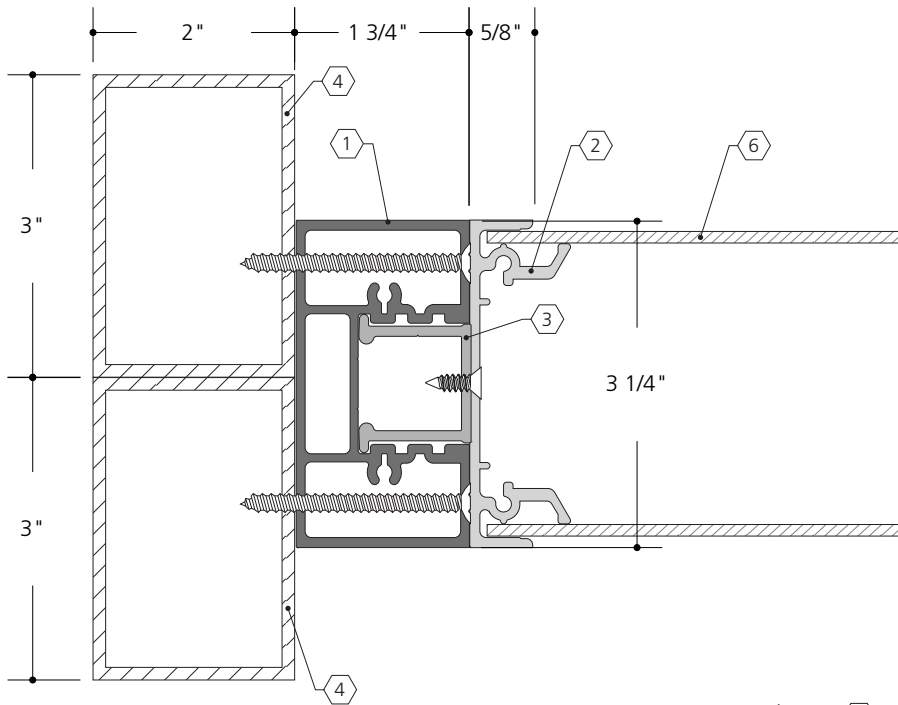

1 Post Section 1 - Cabinet
half scale

- 1 SignComp - series 3 - rectangular post #1220
 - 2 SignComp - series 3 - slide-body #1260
 - 3 SignComp - series 2 - reveal #1200 mechanically fastened to slide body
 - 4 2" x 3" x 1/8" wall alum tube uprights mechanically fastened to 1220 post
 - 5 (not pictured) - SignComp series 3 - post caps
 - 6 1/8" alum or polycarbonate face into slide-body retainer.
- NOTE: Cabinet can be fitted with lamp fixtures to create an internally illuminated sign

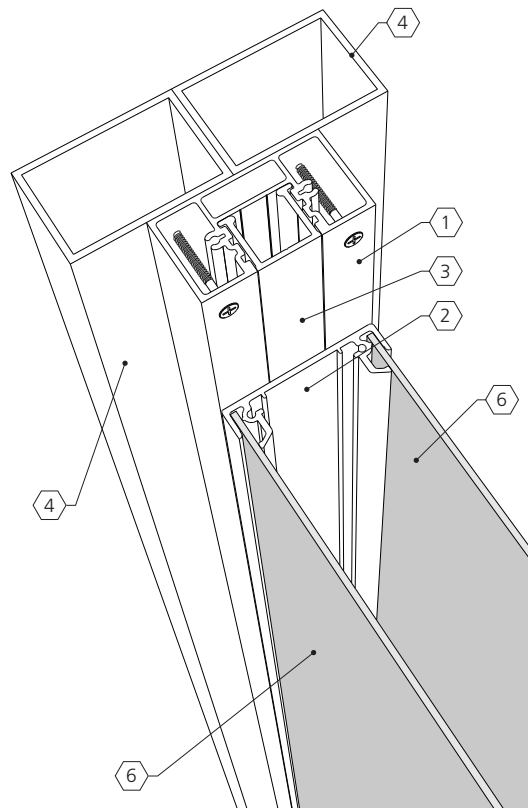

These drawings are meant for DESIGN INTENT ONLY and are not for construction. Contractor shall verify and be responsible for all dimensions and conditions of the job. Contractor shall be familiar with the site and conditions it presents. This office must be notified of any variations from the dimensions and conditions shown on this drawing. Shop drawings and details must be submitted to the City of Austin for approval prior to proceeding with fabrication. All copy shall be proofread by the City of Austin and legal requirements checked by legal department.

2 Perspective Detail
n t s

SECTION DETAILS
POST SECTION 2

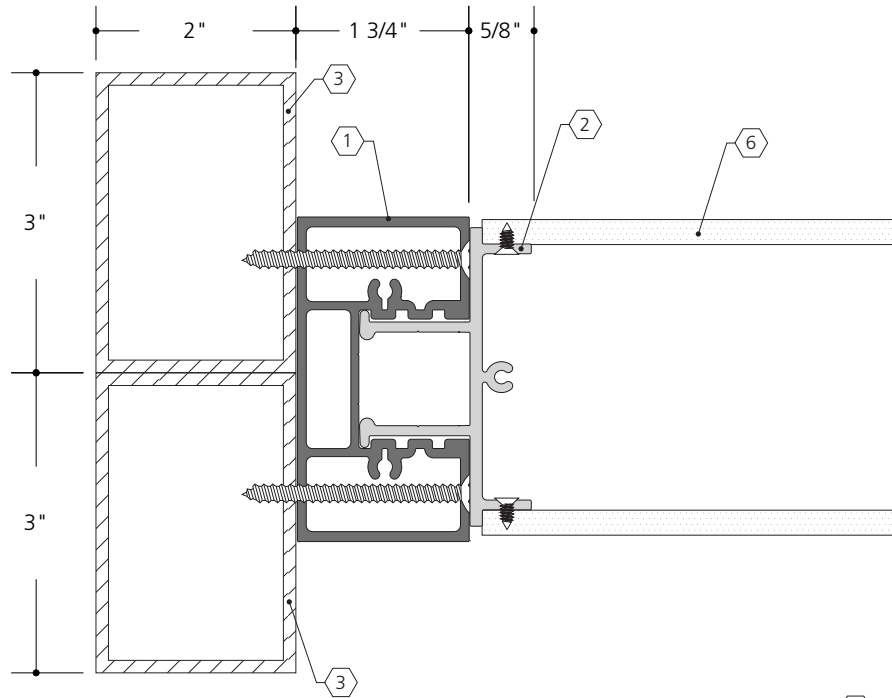

1 Post Section 2 - Two-panel
half scale

- ① SignComp - series 3 - rectangular post #1220
- ② SignComp - series 3 - CB reveal #1260
- ③ 2" x 3" x 1/8 wall alum tube uprights mechanically fastened to 1220 post
- ④ SignComp - series 2 - reveal #1200 (above and below #1260)
- ⑤ (not pictured) - SignComp series 3 - post caps
- ⑥ 1/4" phenolic resin panels mechanically fastened to retainer flange

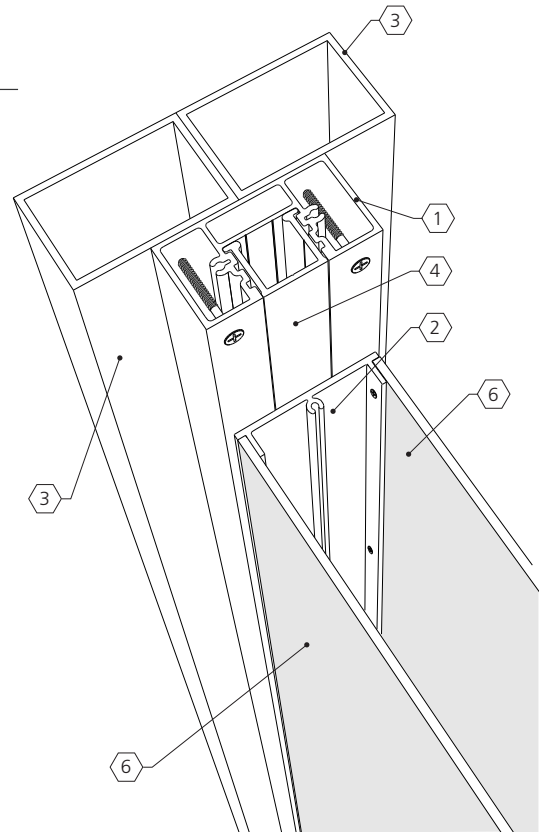

2 Perspective Detail
n t s

These drawings are meant for DESIGN INTENT ONLY and are not for construction. Contractor shall verify and be responsible for all dimensions and conditions of the job. Contractor shall be familiar with the site and conditions it presents. This office must be notified of any variations from the dimensions and conditions shown on this drawing. Shop drawings and details must be submitted to this office for approval prior to proceeding with fabrication. All copy shall be proofread by client and legal requirements checked by legal department.

SECTION DETAILS
POST SECTION 3

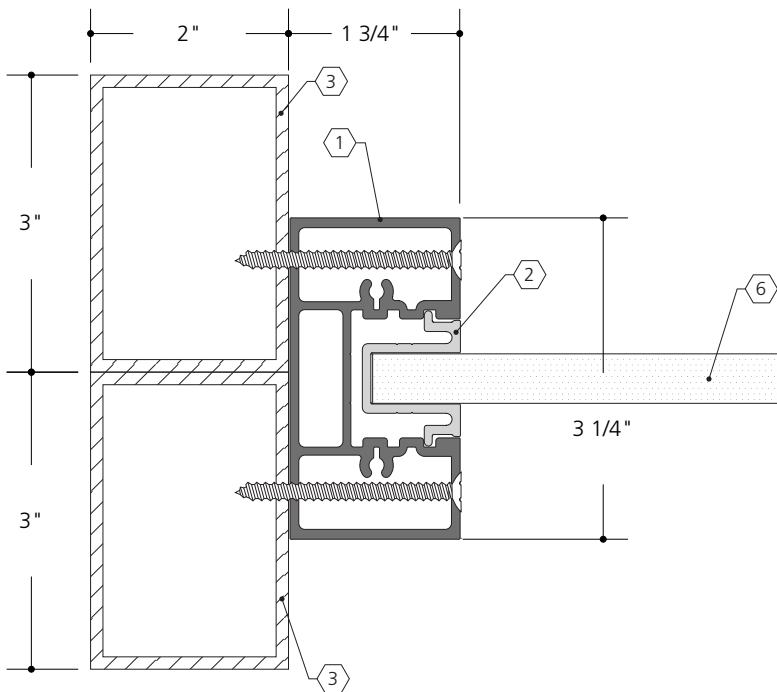

1 Post Section 3 - Single-panel
half scale

- ① SignComp - series 3 - rectangular post #1220
- ② SignComp - series 2 - panel adapter #1204
- ③ 2" x 3" x 1/8 wall alum tube uprights mechanically fastened to 1220 post
- ④ SignComp - series 2 - reveal #1200 (above and below #1204)
- ⑤ (not pictured) - SignComp series 3 - post caps
- ⑥ 1/2" phenolic resin panel - double-faced slides into panel adapter

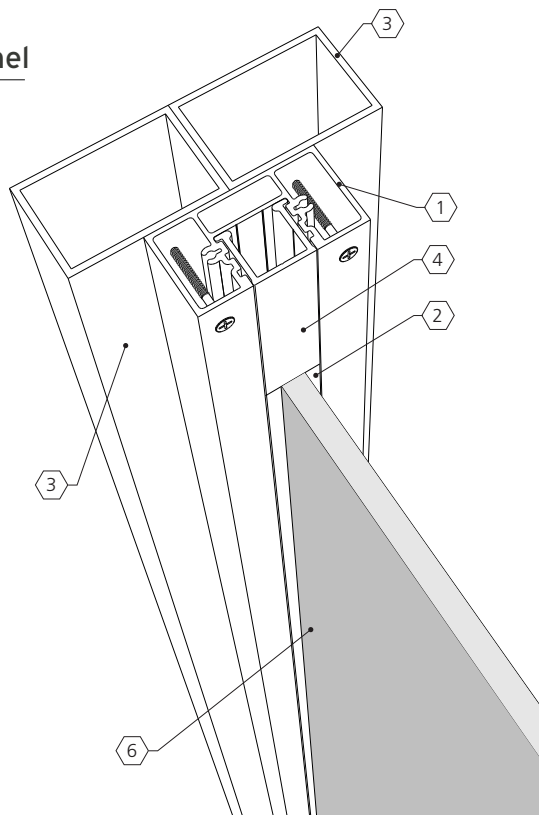

2 Perspective Detail
n t s

These drawings are meant for DESIGN INTENT ONLY and are not for construction. Contractor shall verify and be responsible for all dimensions and conditions of the job. Contractor shall be familiar with the site and conditions it presents. This office must be notified of any variations from the dimensions and conditions shown on this drawing. Shop drawings and details must be submitted to the City of Austin for approval prior to proceeding with fabrication. All copy shall be proofread by the City of Austin and legal requirements checked by legal department.

SECTION DETAILS
PDIR.3 & PDIR.6

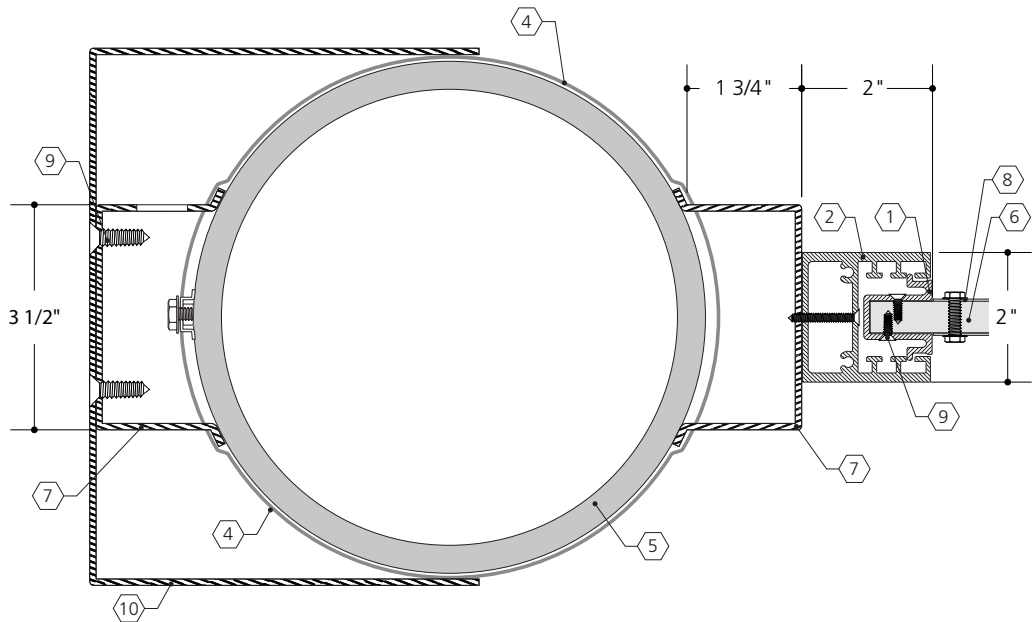

1 Section - PDIR.3/6
scale: 1:3

- 1 SignComp - series 2 - Panel adapter #1204
- 2 SignComp - series 2 - 2" square post #1100
- 3 SignComp - series 2 - 3/8" post cap #5261
- 4 3/4" Band-fast with Color-It polyester coating to match existing light post finish

- 5 Existing light post
- 6 1/2" phenolic resin panel - double-faced
- 7 1/8" brake-formed alum bracket
- 8 Printed vinyl/decorative metal strip through-bolted to resin panel
- 9 Set screws
- 10 Alum cover plate mechanically fastened to alum bracket assembly

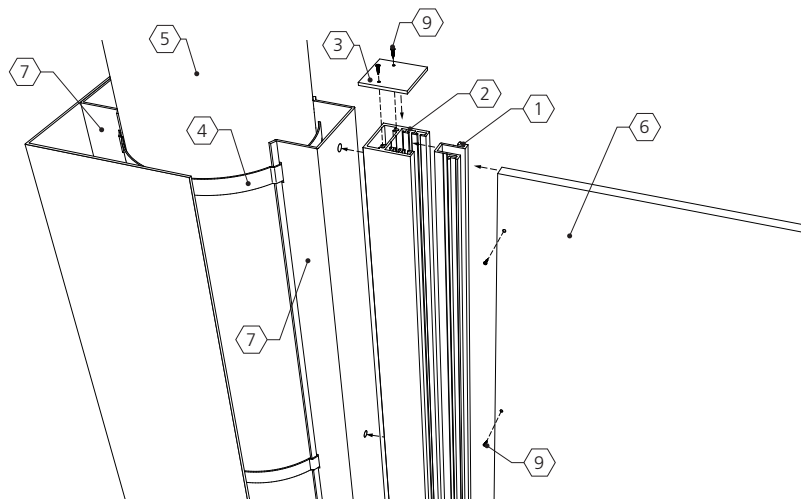

2 Exploded Detail
n t s

These drawings are meant for DESIGN INTENT ONLY and are not for construction. Contractor shall verify and be responsible for all dimensions and conditions of the job. Contractor shall be familiar with the site and conditions it presents. This office must be notified of any variations from the dimensions and conditions shown on this drawing. Shop drawings and details must be submitted to this office for approval prior to proceeding with fabrication. All copy shall be proofread by client and legal requirements checked by legal department.

**SECTION DETAILS
PDIR.3A &
PDIR.6A**

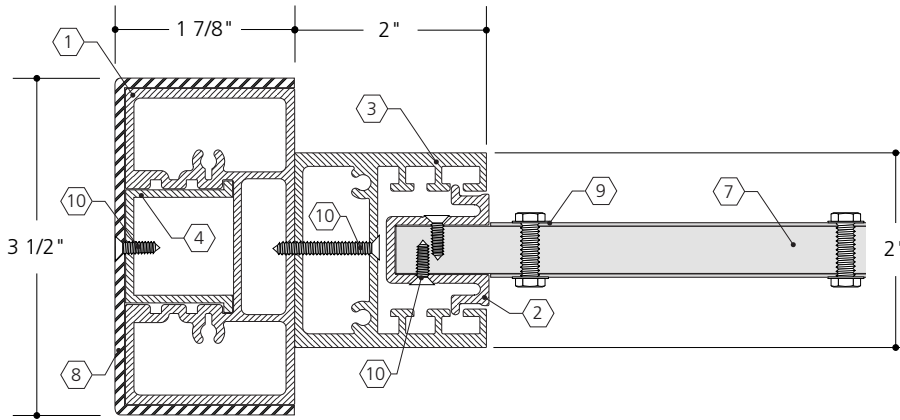

1 Section - PDIR.3/6a
half scale

- ① SignComp - series 3 - 3 1/4" rect. post #1220
- ② SignComp - series 2 - Panel adapter #1204
- ③ SignComp - series 2 - 2" square post #1100
- ④ SignComp - series 2 - reveal #1200
- ⑤ SignComp - series 2 - 3/8" post cap #5261
- ⑥ SignComp - series 3 - 3/8" post cap #5010
- ⑦ 1/2" phenolic resin panel - double-faced
- ⑧ 1/8" brake-formed alum pole cover
- ⑨ Printed vinyl/decorative metal strip through-bolted to resin panel
- ⑩ Set screws

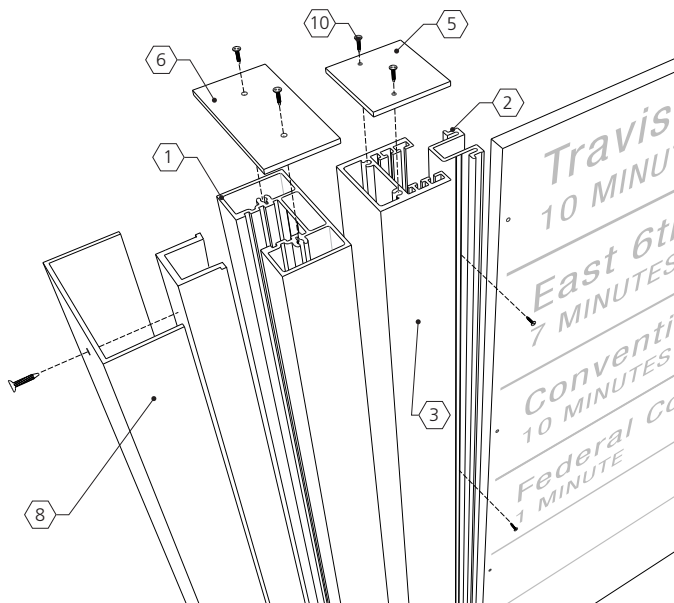

2 Exploded Detail
n t s

These drawings are meant for DESIGN INTENT ONLY and are not for construction. Contractor shall verify and be responsible for all dimensions and conditions of the job. Contractor shall be familiar with the site and conditions it presents. This office must be notified of any variations from the dimensions and conditions shown on this drawing. Shop drawings and details must be submitted to the City of Austin for approval prior to proceeding with fabrication. All copy shall be proofread by the City of Austin and legal requirements checked by legal department.

SECTION DETAILS
STONE BASE

Texas Limestone base details for
DEST.1B
PKIOSK.1
PKIOSK.2
PKIOSK.2A
PKIOSK.3
PKIOSK.3A

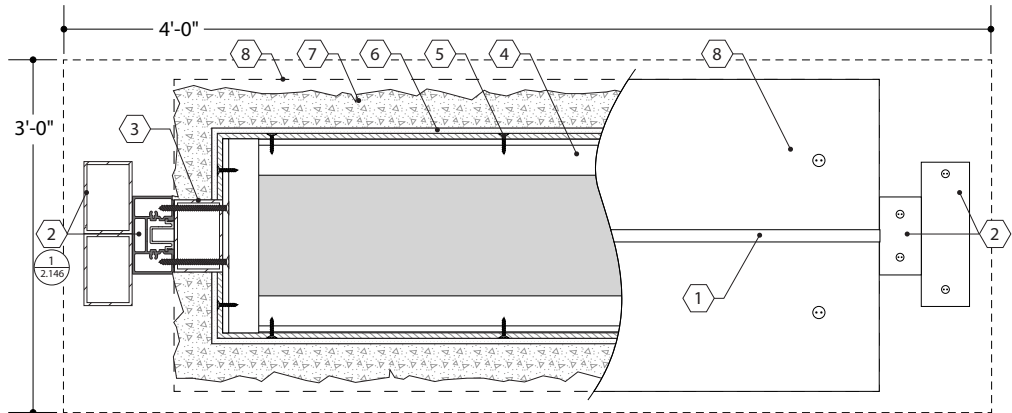

1 Section plan typ KIOSK base
scale: 1 1/2"=1'-0"

- ① Message panel assembly - see post section detail drawings for configuration
- ② Aluminum extrusion frame assembly
- ③ 2" x 3" x 1/4 wall alum tube mechanically fastened to frame assembly
- ④ 1 1/2" x 1 1/2" x 1/4" alum angle frame mechanically fastened to frame assembly
- ⑤ Lathe screen screwed to alum angle frame
- ⑥ Mortar setting bed
- ⑦ Texas Limestone cultured stone by Boral Stone Products - www.culturedstone.com
- ⑧ 3/8" alum plate cap mechanically fastened to alum angle frame - brakeform slightly to create crown for water run-off
- ⑨ Concrete footer - Verify all location conditions.

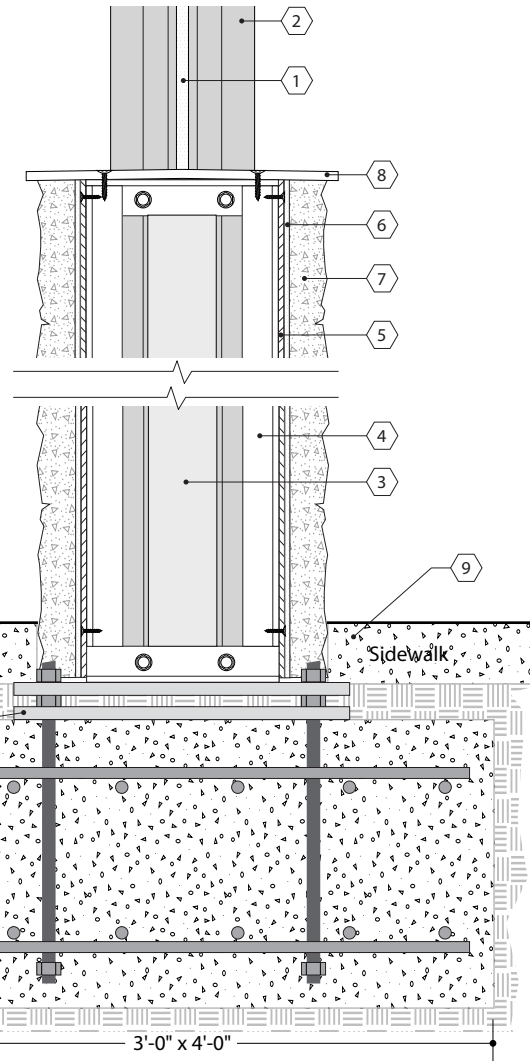

2 Section
scale: 1 1/2"=1'-0"

These drawings are meant for DESIGN INTENT ONLY and are not for construction. Contractor shall verify and be responsible for all dimensions and conditions of the job. Contractor shall be familiar with the site and conditions it presents. This office must be notified of any variations from the dimensions and conditions shown on this drawing. Shop drawings and details must be submitted to this office for approval prior to proceeding with fabrication. All copy shall be proofread by client and legal requirements checked by legal department.

SPECIFICATIONS

Physical Properties:

1. Ultimate Tensile Load = 266.9 kN (60.0 kips) minimum per Anchor.
2. Actual Pullout Strength depends on foundation design and concrete properties.

Installation Instructions:

See other side of page for typical installation diagrams.

1. Fabricate flat steel or wood template with four (4) 19 mm (3/4") diameter holes located to match the specified bolt pattern of the pole base plate.
2. Attach four Female Anchors to template using four (4) 19 mm (3/4") diameter bolts. Ensure that each Anchor Washer is flush and snug against the bottom of the template.
3. Lower Anchor Assembly into fresh concrete foundation, and vibrate into position such that the tops of the Anchor Washers are flush with the finished top surface of the foundation.
4. Support template such that all Anchors are level and in their proper locations.
5. Allow concrete to cure, and then remove bolts and template from the top of the foundation.

Transpo® Type C Female Anchor
for use with Pole-Safe® Model No. 5075
Breakaway Support System for Light Poles

TRANSPO INDUSTRIES, INC.
The Smart Solutions Company
20 Jones Street
New Rochelle, NY 10801
914-636-1000

3/00

**BREAKAWAY
FOOTER DETAILS
VDIR.1-3
PARK.1-3**

PERFORMANCE CRITERIA:

1. Double-Neck Pole-Safe meets all requirements of "AASHTO Standard Specifications for Structural Supports for Highway Signs, Luminaries, and Traffic Signals."

2. Double-Neck Pole-Safe has been crash-tested and FHWA approved in accordance with the requirements of NCHRP Report 350, "Recommended Procedures for the Safety Performance Evaluation of Highway Features."

3. Maximum Allowable Pole Mass = 450 kg (922 lb) (total including fixtures).

**PHYSICAL PROPERTIES
PER COUPLING:**

1. Ultimate Tensile Strength = 221.5 kN (49.8 kips), minimum
2. Tensile Yield Strength = 192.0 kN (43.2 kips), minimum.
3. Ultimate Restrained Shear Strength = 24.5 kN (5.5 kips), maximum

CORROSION PROTECTION:
All Hardware items are American Standard sizes, galvanized in accordance with ASTM A153 (hot dipped).

These drawings are meant for DESIGN INTENT ONLY and are not for construction. Contractor shall verify and be responsible for all dimensions and conditions of the job. Contractor shall be familiar with the site and conditions it presents. This office must be notified of any variations from the dimensions and conditions shown on this drawing. Shop drawings and details must be submitted to the City of Austin for approval prior to proceeding with fabrication. All copy shall be proofread by the City of Austin and legal requirements checked by legal department.

Typical Anchor Layout

Template Bolt (temporary)
Template (temporary)
Top Surface of Concrete Foundation
Transpo® Type C Female Anchor (Typical, 4 per Foundation)
Foundation Form or other means of support for template while concrete cures

See other side of page for complete Installation Instructions

Transpo® Type C Female Anchor
for use with Pole-Safe® Model No. 5075
Breakaway Support System for Light Poles

TRANSPO INDUSTRIES, INC.
The Smart Solutions Company
20 Jones Street
New Rochelle, NY 10801
914-636-1000

3/00

**BREAKAWAY
FOOTER DETAILS
VDIR. 1-3
PARK. 1-3**

- PERFORMANCE CRITERIA:**
1. Double-Neck Pole-Safe meets all requirements of "AASHTO Standard Specifications for Structural Supports for Highway Signs, Luminaries, and Traffic Signals."
 2. Double-Neck Pole-Safe has been crash-tested and FHWA approved in accordance with the requirements of NCHRP Report 350, "Recommended Procedures for the Safety Performance Evaluation of Highway Features."
 3. Maximum Allowable Pole Mass = 450 kg (922 lb) (total including fixtures).

- PHYSICAL PROPERTIES PER COUPLING:**
1. Ultimate Tensile Strength = 221.5 kN (49.8 kips), minimum
 2. Tensile Yield Strength = 192.0 kN (43.2 kips), minimum.
 3. Ultimate Restrained Shear Strength = 24.5 kN (5.5 kips), maximum

CORROSION PROTECTION:
All Hardware items are American Standard sizes, galvanized in accordance with ASTM A153 (hot dipped).

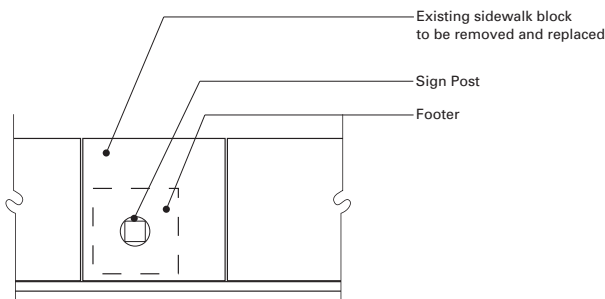
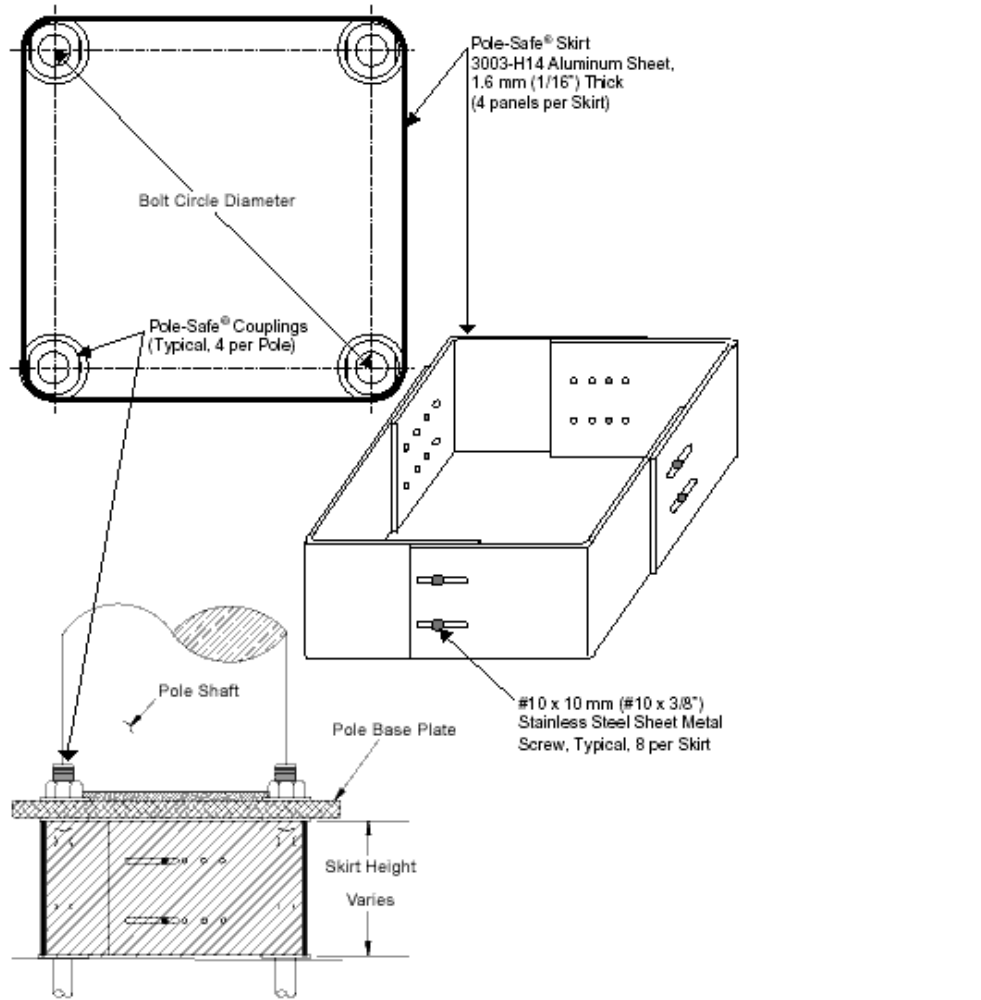

NOTE: When locating a footer within a single pavement block (max. 5'-0" x 5'-0"), adjacent to at least 2 expansion joints, the entire block of pavement shall be removed and replaced with the same materials and finish of adjacent sidewalk areas.

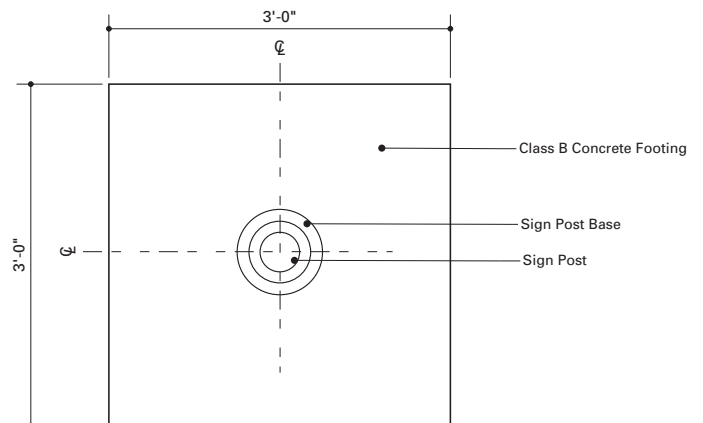

1 Plan: Footer Placement
SCALE: NTS

2 Plan View: Footer
SCALE: 1" = 1' - 0"

These drawings are meant for DESIGN INTENT ONLY and are not for construction. Contractor shall verify and be responsible for all dimensions and conditions of the job. Contractor shall be familiar with the site and conditions it presents. This office must be notified of any variations from the dimensions and conditions shown on this drawing. Shop drawings and details must be submitted to this office for approval prior to proceeding with fabrication. All copy shall be proofread by client and legal requirements checked by legal department.

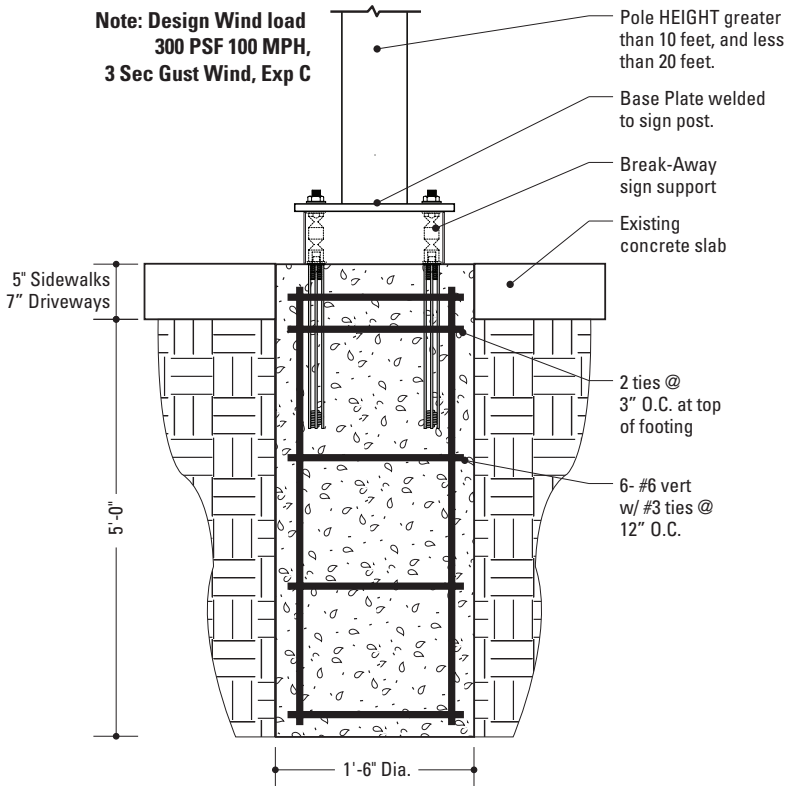

Section View: Foundation @ Concrete

Pole Height - 10 to 20 ft.

1

SCALE: 3/4" = 1'-0"

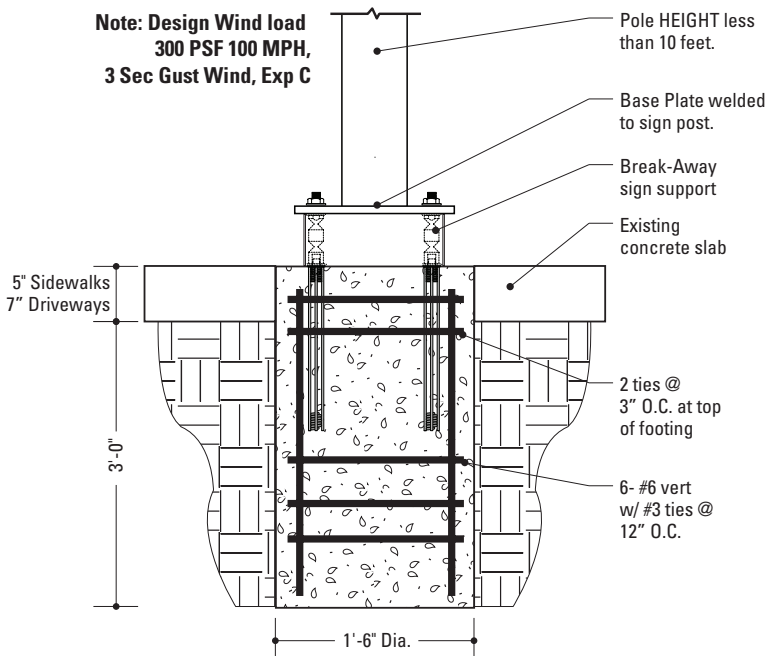

Section View: Foundation @ Concrete

Pole Height - Less than 10 ft.

2

SCALE: 3/4" = 1'-0"

**BREAKAWAY
FOOTER DETAILS
VDIR. 1-3
PARK. 1-3**

The Contractor shall be familiar with all site conditions and shall be responsible for all underground utility checks.

The Contractor shall be familiar with all basement/vault locations by obtaining plans from the City of Austin Department of Public Works.

Where a basement/vault interferes with a proposed location. The sign shall be relocated to a location deemed appropriate by the City of Austin Department of Public Works

Where relocation is not an option the Contractor will develop the appropriate mounting solution. The solution shall meet all engineering criteria as established by the standard footings. (i.e. windloads)

Final designs and shop drawings shall be supplied by the Contractor for each of the Break-away poles identified and a TEXAS Registered Professional Engineer is required to sign and seal the submittal of shop drawings.

NOTE:

- 1) Soil is average with minimum allowable soil pressure of 2,000 pounds per square foot. Soil unit weight of 125 PCF and friction angle of 30 degrees (assumed).
- 2) Concrete Strength at 28 days $f'c=3,000$ PSI Reinforcement shall be ASTM A615 $F_y=60,000$ PSI
- 3) FOLLOW TXDOT DESIGN STANDARDS FOR MATERIAL AND CONSTRUCTION INFORMATION FOR THE SIGN POST BASES AND FOUNDATIONS NOT OTHERWISE SPECIFIED IN THESE CONTRACT DRAWINGS
- 4) FOR SIGN POST SIZES REFER TO THE DESIGN INTENT DRAWING SHEETS, Contractor to verify appropriate structural post size requirements.

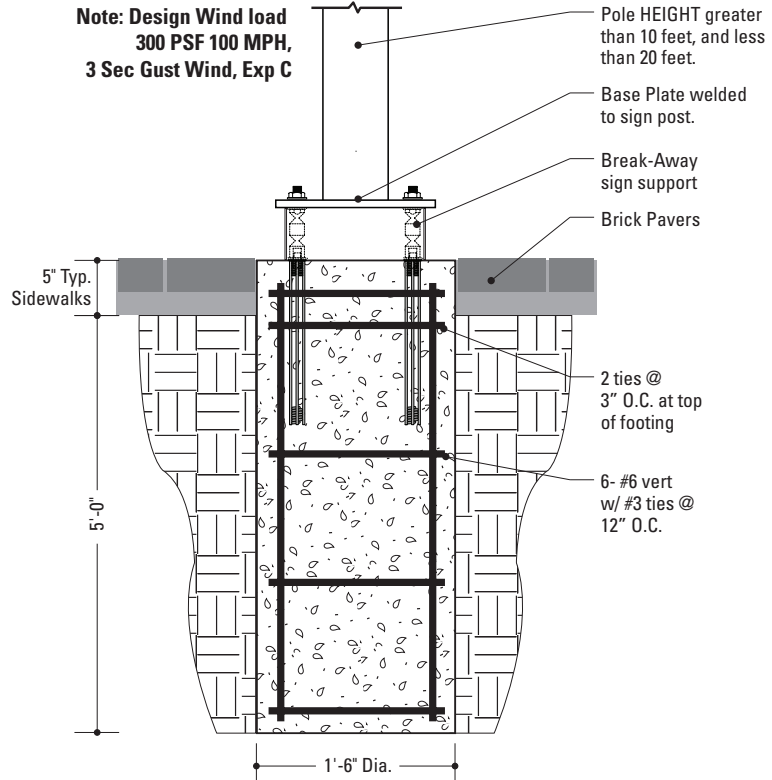

Section View: Foundation @ Pavers

Pole Height - 10 to 20 ft.

3

SCALE: 3/4" = 1'-0"

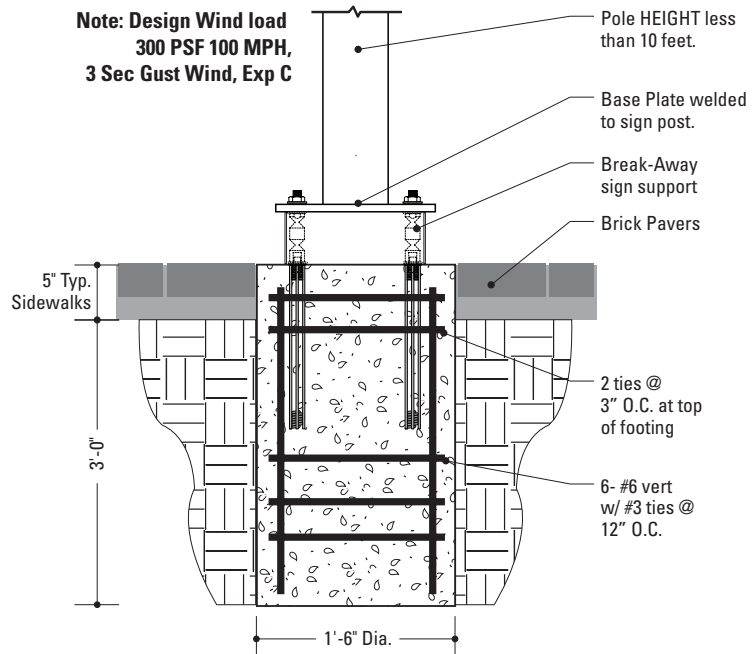

Section View: Foundation @ Pavers

Pole Height - Less than 10 ft.

4

SCALE: 3/4" = 1'-0"

These drawings are meant for DESIGN INTENT ONLY and are not for construction. Contractor shall verify and be responsible for all dimensions and conditions of the job. Contractor shall be familiar with the site and conditions it presents. This office must be notified of any variations from the dimensions and conditions shown on this drawing. Shop drawings and details must be submitted to this office for approval prior to proceeding with fabrication. All copy shall be proofread by client and legal requirements checked by legal department.

**TXDOT BREAKAWAY
FOOTER DETAILS
VDIR.4-6**

The Contractor shall be familiar with all site conditions and shall be responsible for all underground utility checks.

The Contractor shall be familiar with all basement/vault locations by obtaining plans from the City of Austin Department of Public Works.

Where a basement/vault interferes with a proposed location. The sign shall be relocated to a location deemed appropriate by the City of Austin Department of Public Works

Where relocation is not an option the Contractor will develop the appropriate mounting solution. The solution shall meet all engineering criteria as established by the standard footings. (i.e. windloads)

Final designs and shop drawings shall be supplied by the Contractor for each of the Break-away poles identified and a TEXAS Registered Professional Engineer is required to sign and seal the submittal of shop drawings.

NOTE:
1) Soil is average with maximum allowable soil pressure of 3,000 pounds per square foot. Soil unit weight of 125 PCF and friction angle of 30 degrees (assumed).

2) Concrete Strength at 28 days $f'c=4,000$ PSI
Reinforcement shall be ASTM 36 $F_y=60,000$ PSI

3) FOLLOW TXDOT DESIGN STANDARDS FOR MATERIAL AND CONSTRUCTION INFORMATION FOR THE SIGN POST BASES AND FOUNDATIONS NOT OTHERWISE SPECIFIED IN THESE CONTRACT DRAWINGS

4) FOR SIGN POST SIZES REFER TO THE DESIGN INTENT DRAWING SHEETS, Contractor to verify appropriate structural post size requirements.

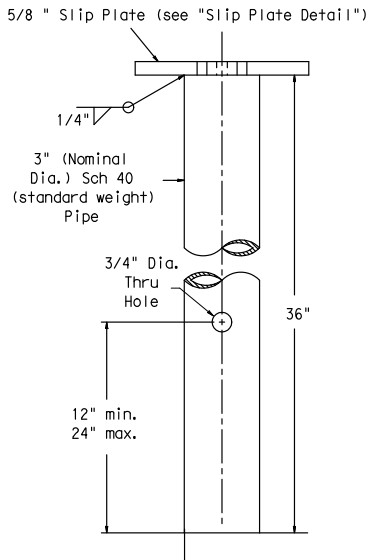

Pipe shall conform to ASTM A53 Gr B, A500 Gr B, or A501. Galvanize according to ASTM A123 after all fabrication is completed. Finished components shall be permanently marked to indicate manufacturer. Method, design and location of markings are subject to the approval of the TxDOT Traffic Standards Engineer.

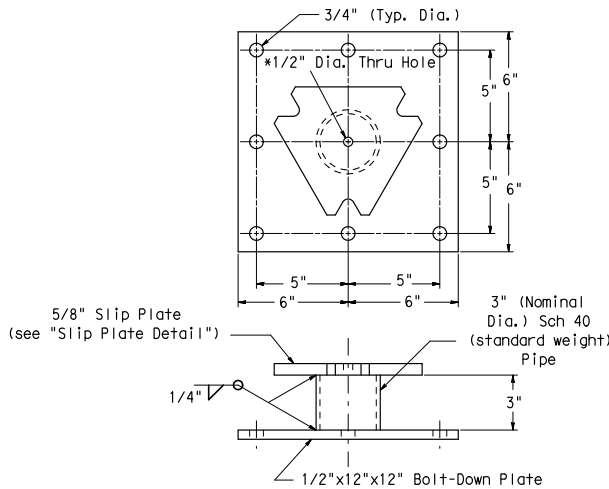

Pipe shall conform to ASTM A53 Gr B, A500 Gr B, or A501. Bolt-down plate shall conform to the same material requirements specified for the slip plate. Galvanize according to ASTM A123 after all fabrication is completed. Finished components shall be permanently marked to indicate manufacturer. Method, design and location of markings are subject to the approval of the TxDOT Traffic Standards Engineer.

* Hole in slip plate and bolt-down plate is for galvanizing venting and drainage. Exact hole placement may vary as needed.

STUB

BOLT-DOWN ANCHOR

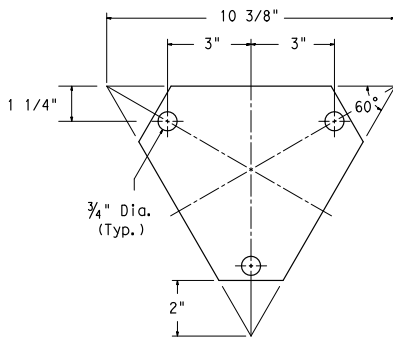

Bolt Keeper Plate shall be manufactured from 26 to 30 gauge galvanized sheet steel.

BOLT KEEPER PLATE

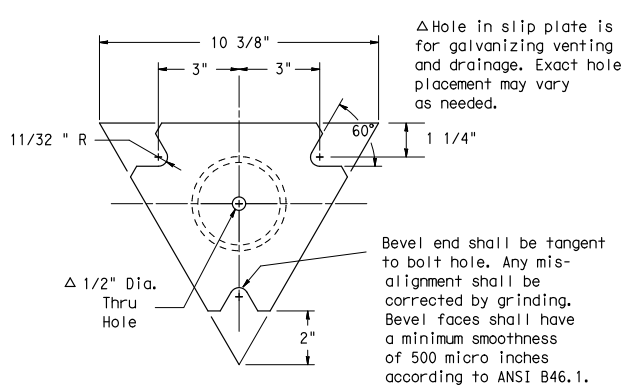

Slip plate shall conform to ASTM A36 or A572.

SLIP PLATE DETAIL

These drawings are meant for DESIGN INTENT ONLY and are not for construction. Contractor shall verify and be responsible for all dimensions and conditions of the job. Contractor shall be familiar with the site and conditions it presents. This office must be notified of any variations from the dimensions and conditions shown on this drawing. Shop drawings and details must be submitted to this office for approval prior to proceeding with fabrication. All copy shall be proofread by client and legal requirements checked by legal department.

**TXDOT BREAKAWAY
FOOTER DETAILS
VDIR.4-6**

The Contractor shall be familiar with all site conditions and shall be responsible for all underground utility checks.

The Contractor shall be familiar with all basement/vault locations by obtaining plans from the City of Austin Department of Public Works.

Where a basement/vault interferes with a proposed location. The sign shall be relocated to a location deemed appropriate by the City of Austin Department of Public Works

Where relocation is not an option the Contractor will develop the appropriate mounting solution. The solution shall meet all engineering criteria as established by the standard footings. (i.e. windloads)

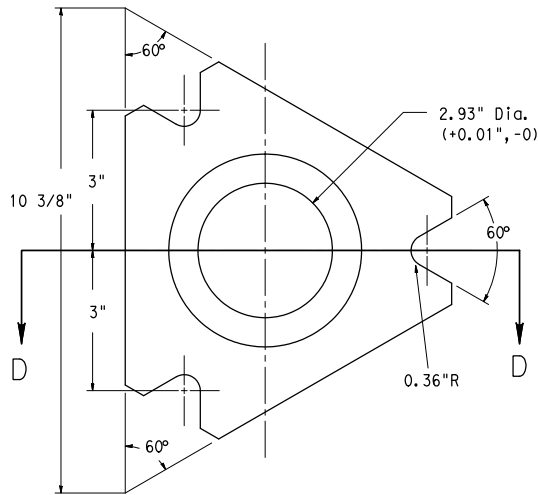

Final designs and shop drawings shall be supplied by the Contractor for each of the Break-away poles identified and a TEXAS Registered Professional Engineer is required to sign and seal the submittal of shop drawings.

NOTE:
1) Soil is average with maximum allowable soil pressure of 3,000 pounds per square foot. Soil unit weight of 125 PCF and friction angle of 30 degrees (assumed).

2) Concrete Strength at 28 days $f'c=4,000$ PSI
Reinforcement shall be ASTM 36 $F_y=60,000$ PSI

3) FOLLOW TXDOT DESIGN STANDARDS FOR MATERIAL AND CONSTRUCTION INFORMATION FOR THE SIGN POST BASES AND FOUNDATIONS NOT OTHERWISE SPECIFIED IN THESE CONTRACT DRAWINGS

4) FOR SIGN POST SIZES REFER TO THE DESIGN INTENT DRAWING SHEETS, Contractor to verify appropriate structural post size requirements.

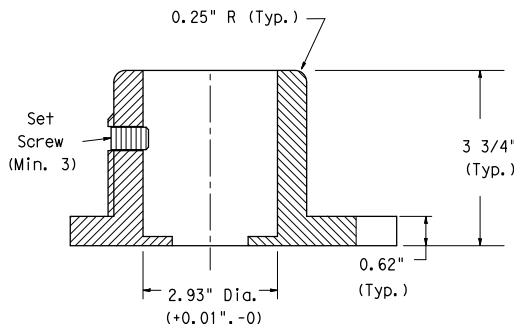

Set Screw type Section D-D

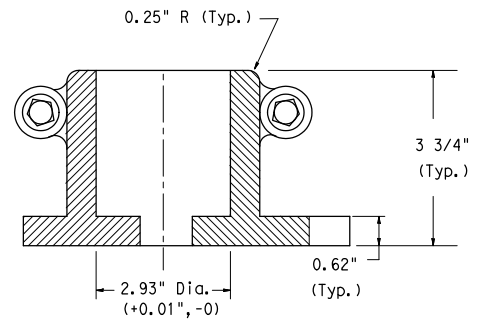

Bolt Clamp type Section D-D

Steel Slipbase fabrication shall conform to ASTM A36 or A572, if fabrication consists of ductile iron casting it shall conform to ASTM A536 Grade 65-45-12 and be galvanized per ASTM a153 Class A.

Finished components shall be permanently marked to indicate manufacturer. Method, design and location of markings are subject to the approval of the TxDOT Traffic Standards Engineer.

A list of approved Triangular Slip bases can be found at http://www.txdot.gov/business/producer_list.htm

SLIPBASE DETAIL

These drawings are meant for DESIGN INTENT ONLY and are not for construction. Contractor shall verify and be responsible for all dimensions and conditions of the job. Contractor shall be familiar with the site and conditions it presents. This office must be notified of any variations from the dimensions and conditions shown on this drawing. Shop drawings and details must be submitted to this office for approval prior to proceeding with fabrication. All copy shall be proofread by client and legal requirements checked by legal department.

**TXDOT BREAKAWAY
FOOTER DETAILS
VDIR.4-6**

The Contractor shall be familiar with all site conditions and shall be responsible for all underground utility checks.

The Contractor shall be familiar with all basement/vault locations by obtaining plans from the City of Austin Department of Public Works.

Where a basement/vault interferes with a proposed location. The sign shall be relocated to a location deemed appropriate by the City of Austin Department of Public Works

Where relocation is not an option the Contractor will develop the appropriate mounting solution. The solution shall meet all engineering criteria as established by the standard footings. (i.e. windloads)

Final designs and shop drawings shall be supplied by the Contractor for each of the Break-away poles identified and a TEXAS Registered Professional Engineer is required to sign and seal the submittal of shop drawings.

NOTE:

1) Soil is average with maximum allowable soil pressure of 3,000 pounds per square foot. Soil unit weight of 125 PCF and friction angle of 30 degrees (assumed).

2) Concrete Strength at 28 days f'c=4,000 PSI Reinforcement shall be ASTM 36 Fy=60,000 PSI

3) FOLLOW TXDOT DESIGN STANDARDS FOR MATERIAL AND CONSTRUCTION INFORMATION FOR THE SIGN POST BASES AND FOUNDATIONS NOT OTHERWISE SPECIFIED IN THESE CONTRACT DRAWINGS

4) FOR SIGN POST SIZES REFER TO THE DESIGN INTENT DRAWING SHEETS, Contractor to verify appropriate structural post size requirements.

Concrete anchor consists of 5/8" diameter stud bolt with UNC series bolt threads on the upper end. Heavy hex nut per ASTM A563, and hardened washer per ASTM F436. The stud bolt shall have minimum yield and ultimate tensile strengths of 50 and 75 KSI, respectively. Nuts, bolts and washers shall be galvanized per Item 445, "Galvanizing." Top of bolt shall extend at least flush with top of the nut when installed. The anchor, when installed in 4000 psi normal-weight concrete with a 5 1/2" minimum embedment, shall have a minimum allowable tension and shear of 3900 and 3100 psi, respectively. Adhesive type anchors shall have stud bolts installed with Type III epoxy per DMS-6100, "Epoxyes and Adhesives." Adhesive anchors may be loaded after adequate epoxy cure time, per the manufacturer's recommendations.

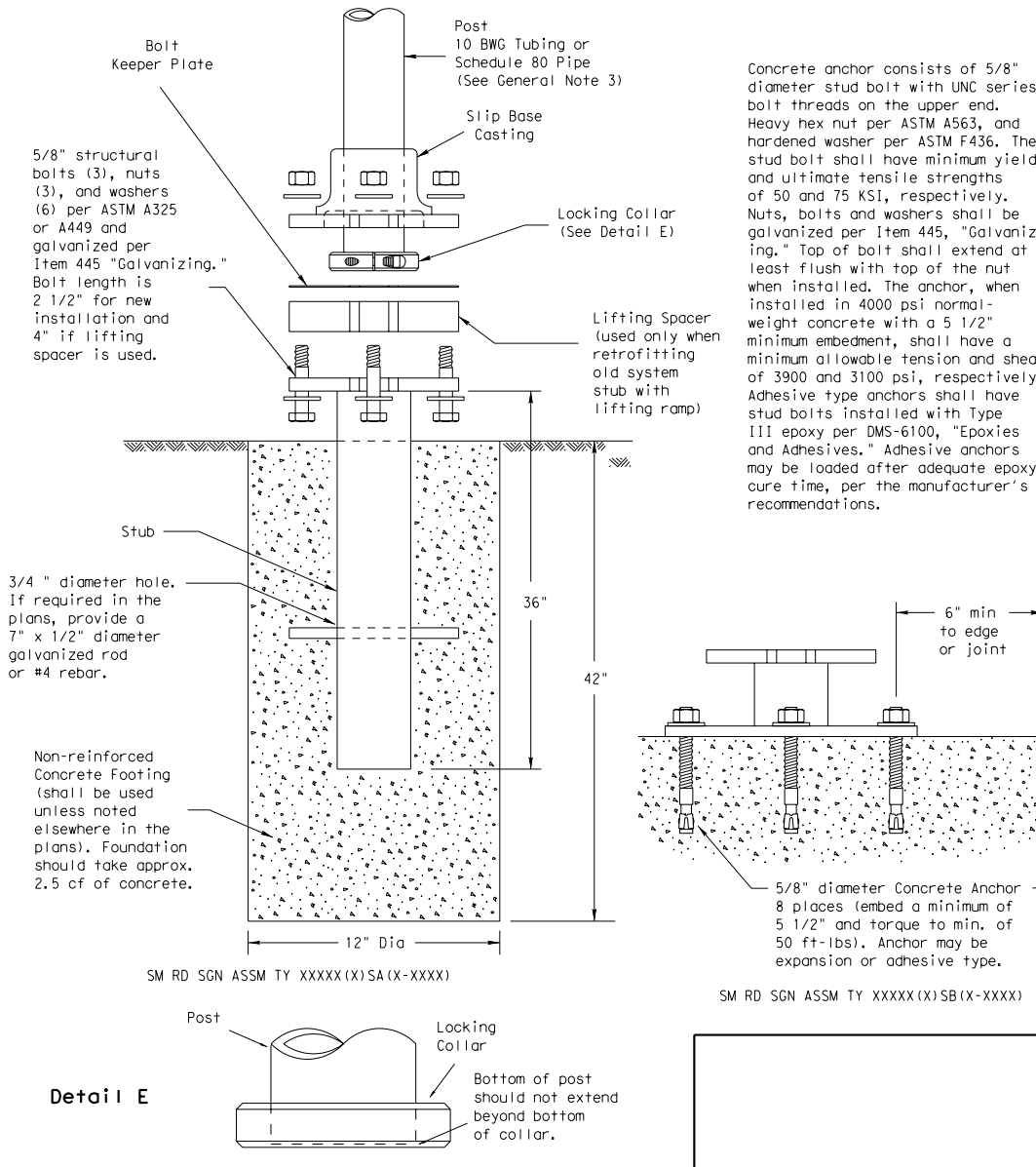

These drawings are meant for DESIGN INTENT ONLY and are not for construction. Contractor shall verify and be responsible for all dimensions and conditions of the job. Contractor shall be familiar with the site and conditions it presents. This office must be notified of any variations from the dimensions and conditions shown on this drawing. Shop drawings and details must be submitted to this office for approval prior to proceeding with fabrication. All copy shall be proofread by client and legal requirements checked by legal department.



section 3

TECHNICAL SPECIFICATIONS

This page is intentionally left blank.

